

Hydraulic Drive Assemblies

Pump, Hydraulic Motor, Mounting Rails
1450 RPM

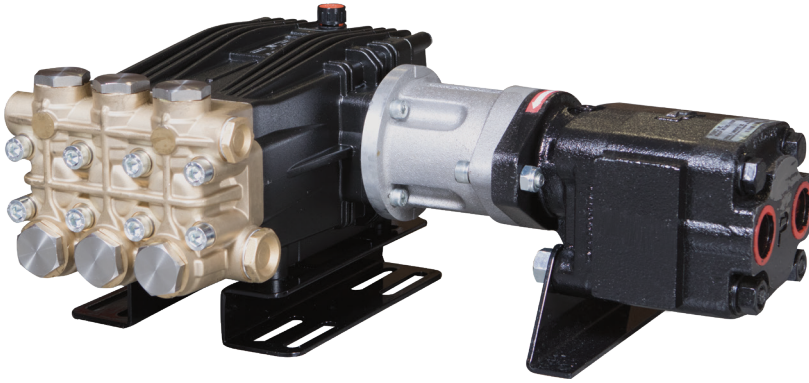

- Heavy Duty Brass Manifold with External and Internal Bracing
- Heavy Duty Bronze or Aluminum Connecting Rods
- Large Diameter Brass or Stainless Steel Valve Caps with Increased Thread Depth
- Reinforcing Ring on Inlet and Discharge Ports
- Stainless Steel Piston Guides and Check Valves
- Heat Treated Crank Shaft
- Industrial Quality Tapered Roller Bearings
- Deeper Back Cover for Increased Oil Capacity
- 34.5 oz. Capacity Vented Oil Bath Crank Case
- 3/4" BSP-F Inlet. 3/8" BSP-F Outlet - Less Than 10 GPM
- 3/4" BSP-F Inlet. 1/2" BSP-F Outlet - 10 GPM and Above
- Max Fluid Temp, 160°F

CKC Series Hydraulic Drive Assemblies

CKC Series super duty hydraulic drive plunger pump assemblies include a wide range of models with flow rates from 4.5 to 13.2 GPM and pressures up to 5000 PSI.

Applications include general pressure cleaning, sewer jetting, vehicle wash equipment, street cleaning, construction, hydro-excavation and UHP fire fighting applications.

	Model	GPM	l/min	PSI*	bar*	Hydraulic Requirements	Weight
1450 RPM	CKC 17/30 SH	4.5	17.0	4000	275	20.0 GPM @ 2000 PSI	75 lbs
	CKC 17/36 SH	4.5	17.0	5000	350	20.0 GPM @ 2200 PSI	75 lbs
	CKC 21/30 SH	5.5	21.0	4000	275	20.0 GPM @ 2400 PSI	75 lbs
	CKC 21/36 SH	5.5	21.0	5000	350	20.0 GPM @ 2400 PSI	75 lbs
	CKC 26/30 SH	6.9	26.0	4000	275	20.0 GPM @ 2400 PSI	75 lbs
	CKC 30/24 SH	7.9	30.0	3500	240	20.0 GPM @ 2400 PSI	75 lbs
	CKC 34/25 SH	9.0	34.0	3200	220	20.0 GPM @ 2400 PSI	75 lbs
	CKC 38/20 SH	10.0	38.0	3000	200	20.0 GPM @ 2400 PSI	75 lbs
	CKC 42/20 SH	11.6	44.0	2500	175	20.0 GPM @ 2400 PSI	75 lbs
	CKC 50/20 SH	13.2	50.0	2000	140	20.0 GPM @ 2400 PSI	75 lbs
1450 RPM	CKC __/__ SHK	CK Series Hydraulic Drive Plunger Pump with hydraulic gear motor, mounting rails, unloader, (2) 1" hose barb inlets, thermal relief valve, safety pop-off valve and 14" x 20" base with rubber bumpers.					100 lbs

* NOTE: Pressure ratings are based on maximum hydraulic motor output capacity



MAX FLOW
 MAX PRESSURE
 RATED PUMP SPEED
 HYDRAULIC REQUIREMENT
 LUBRICATION

4.5 GPM / 17.0 L/MIN
 5000 PSI / 350 BAR
 1450 RPM
 20.0 GPM / 2200 PSI
 34.5 OZ UDOR LUBE

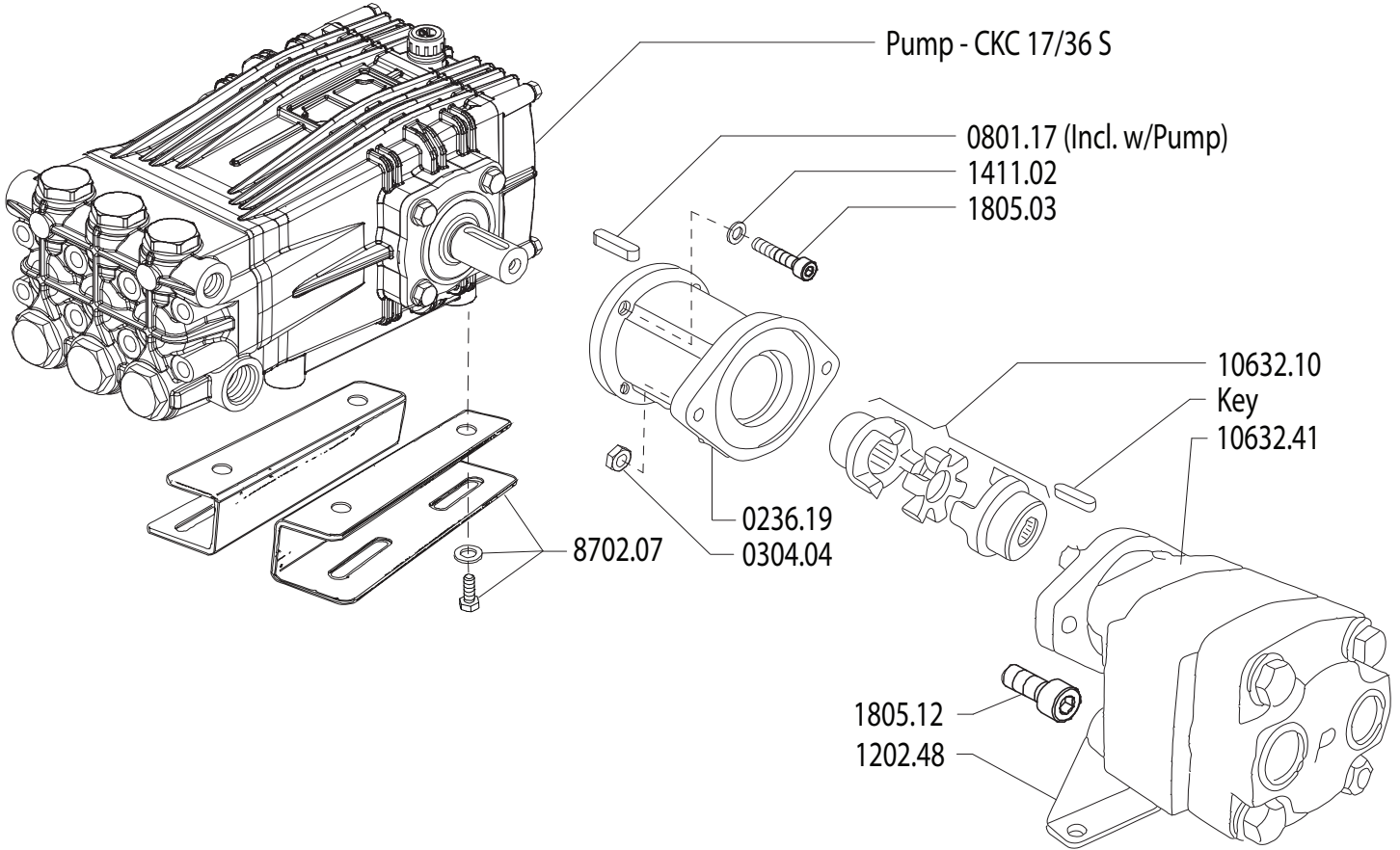

Revised 6-19-2025

Part #	Description	Qty
0236.19	ADAPTER HYDRAULIC MOTOR	1
0304.04	NUT - M10	2
1411.02	WASHER - D8	4
1411.03	WASHER - D10	2
1805.03	ALLEN BOLT M8X30	4

Part #	Description	Qty
1805.12	ALLEN BOLT M10X500	2
8702.07	RAIL KIT WITH BOLTS/WASHERS	1
10632.10	COUPLER 24MMX3/4	1
10632.41	HYDRAULIC MOTOR CK	1
CKC1736S	PUMP - CKC 17/36 S, 4.5 GPM @ 5000 PSI	1

MAX FLOW
MAX PRESSURE
RATED PUMP SPEED
POWER REQUIREMENT
LUBRICATION

4.5 GPM @ 17.0 L/MIN
5075 PSI / 360 BAR
1450 RPM
15.3 HP ELECTRIC
34.5 OZ UDOR LUBE

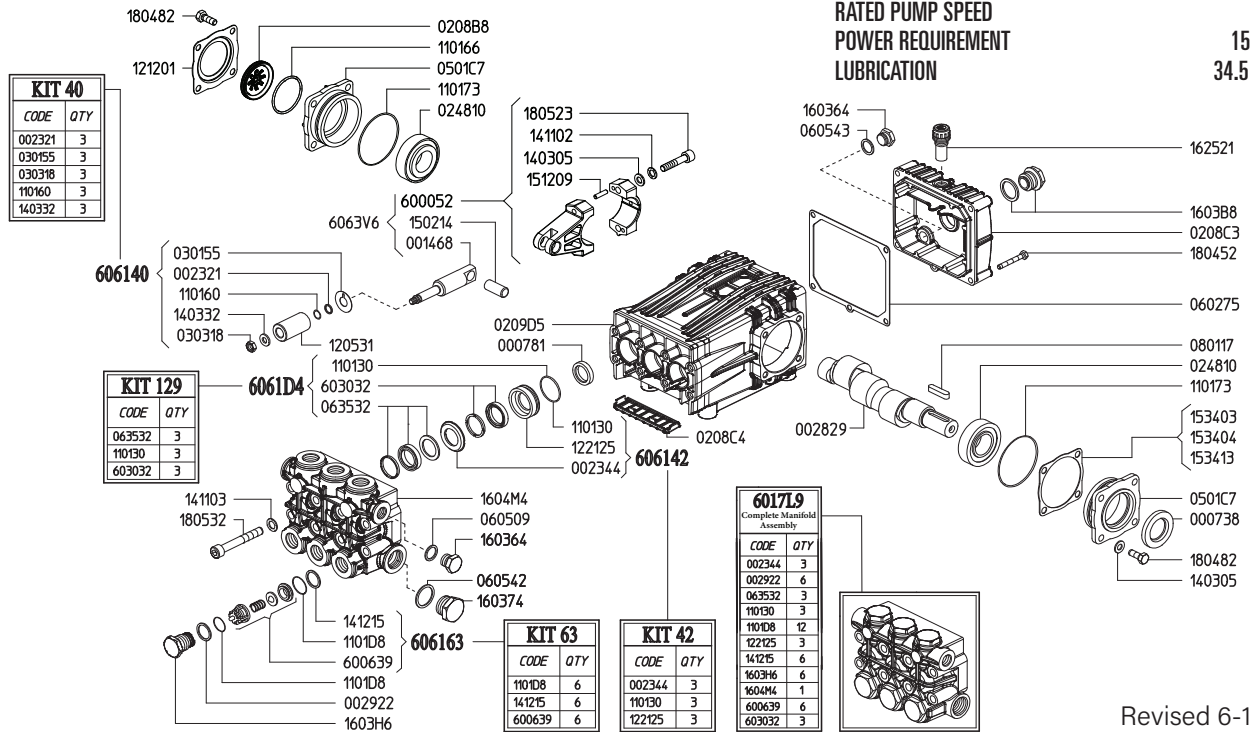

Revised 6-19-2025

Part #	Description	Qty
0007.38	OIL SEAL D30	1
0007.81	OIL SEAL D20	3
0014.68	PLUNGER GUIDE D20 "C/CK"	3
0023.21	RING D8.3 ^B	3
0023.44	UPPER RING D20 "CK" 350BAR ^{D E}	3
0028.29	MALE SHAFT D24	1
0029.22	RING "CK" D15.2 ^E	6
0208.B8	OIL SIGHT GLASS	1
0208.C3	BACK COVER "C/CK"	1
0208.C4	COVER "CK"	1
0209.D5	CRANKCASE "C/CK/CH"	1
0248.10	ROLLER BEARING D30	2
0301.55	SLINGER RING D18/20 ^B	3
0303.18	NUT INOX ^B	3
0501.C7	BEARING HOLLOW FLANGE	2
0602.75	BACK COVER GASKET	1
0605.09	GASKET D17	1
0605.42	GASKET D27	1
0605.43	GASKET D17	1
0635.32	HIGH PRESSURE SEAL KIT D20 ^C	3
0801.17	KEY A8X7X35	1
1101.30	O-RING - PRESSURE RING ^{C D}	3
1101.60	O-RING - PLUNGER ^B	3
1101.66	O-RING - OIL SIGHT GLASS	1
1101.73	O-RING - BEARING FLANGE	2
1101.D8	O-RING - VALVE ^{A E}	6
1101.D8	O-RING - VALVE PLUG ^E	6
1205.31	CERAMIC PLUNGER D20	3
1212.01	RETAINER - OIL SIGHT GLASS	1
1221.25	PRESSURE RING D20 "CK" 350BAR ^{D E}	3
1403.05	WASHER D8.4	10

Part #	Description	Qty
1403.32	WASHER D8.5 ^B	3
1411.02	SERATED WASHER D8	6
1411.03	SERATED WASHER D10	8
1412.15	RING 400BAR ^{A E}	6
1502.14	PIN D14X32	3
1512.09	PLUG D5X20 UNI1707	6
1534.03	SHIM 0.1MM	-
1534.04	SHIM 0.2MM	-
1534.13	SHIM 0.05MM	-
1603.64	PLUG G3/8	2
1603.74	PLUG G3/4	1
1603.B8	OIL PLUG G3/4 + GASKET	1
1603.H6	VALVE PLUG "CK" PISTON D20 ^E	6
1604.M4	HEAD "CK" D18/20 ^E	1
1625.05	OIL PLUG G3/8	1
1804.52	HEX BOLT M6X45	5
1804.82	HEX BOLT M8X22	8
1805.23	ALLEN BOLT M8X40	6
1805.32	ALLEN BOLT M10X75	8
6000.52	ROD ASSEMBLY	3
6006.39	VALVE ASSY 400BAR W/O O-RING ^{A E}	6
6017.L9	COMPLETE MANIFOLD ASSEMBLY	1
6030.32	LOW PRESSURE SEAL KIT D20 ^{C E}	3
6061.40	KIT 40 PLUNGER KIT D20 350BAR	1
6061.42	KIT 42 BRASS RING KIT D20 "CK" 350BAR	1
6061.63	KIT 63 VALVE KIT 400BAR	1
6061.D4	KIT 129 WATER SEAL KIT D20 "CK"	1

^A Parts in 6061.63 (Kit 63).

^B Parts in 6061.40 (Kit 40).

^C Parts in 6061.D4 (Kit 129).

^D Parts in 6061.42 (Kit 42).

^E Parts in 6017.L9 (Complete Manifold Assembly).

CK SERIES PUMPS BELOW 10 GPM

*Dimensional Drawings are
Shown in Millimeters.
To Convert to Inches,
Multiply Dimension x 0.03937*

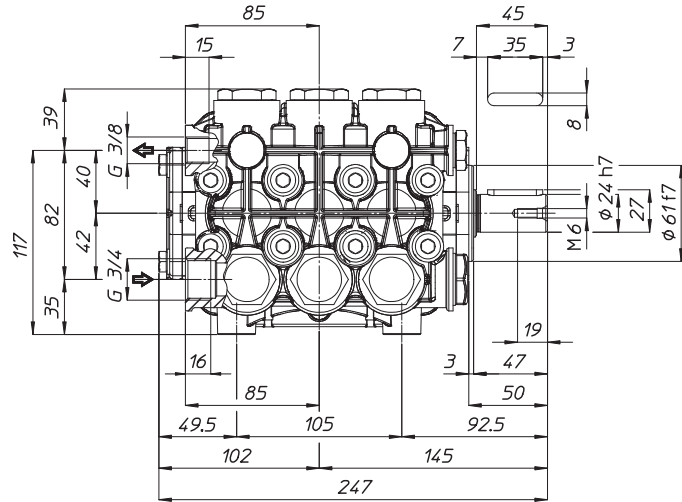
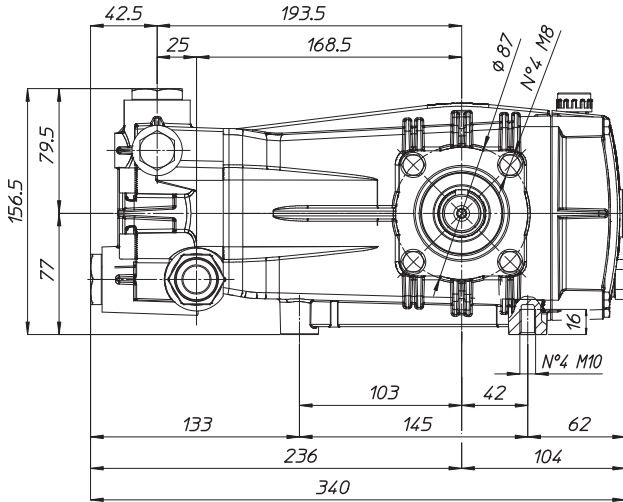

CK SERIES HYDRAULIC DRIVE ASSEMBLIES

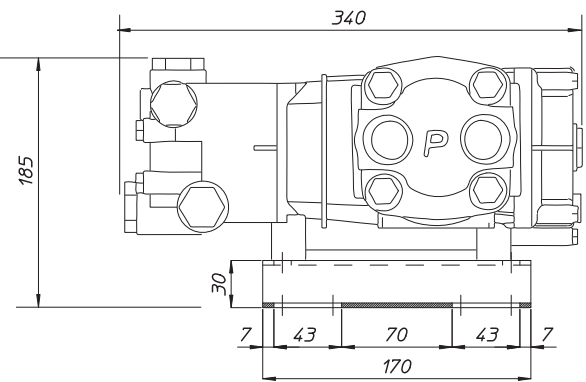
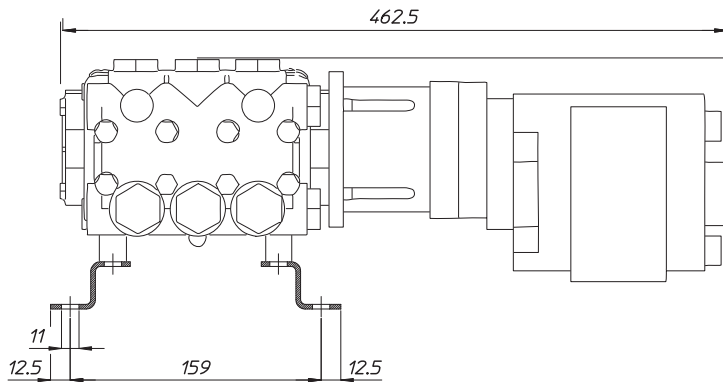

TORQUE SPECS

Ref.	Description	Ft./lb.	Nm	Loctite®
1	Head Bolts	37	50	-
2	Valve Caps	103	140	243
3	Inlet Cap	103	140	-
4	Outlet Cap	103	140	243
5	Bearing Flange Bolts	19	25	-
6	Rear Cover Bolts	8	11	-
7	Connecting Rod Bolts	19	25	270
8	Plunger Bolts	15	20	270
9	Valve Cover Bolts	-	-	-
10	Oil Drain Plug	8	11	-

