

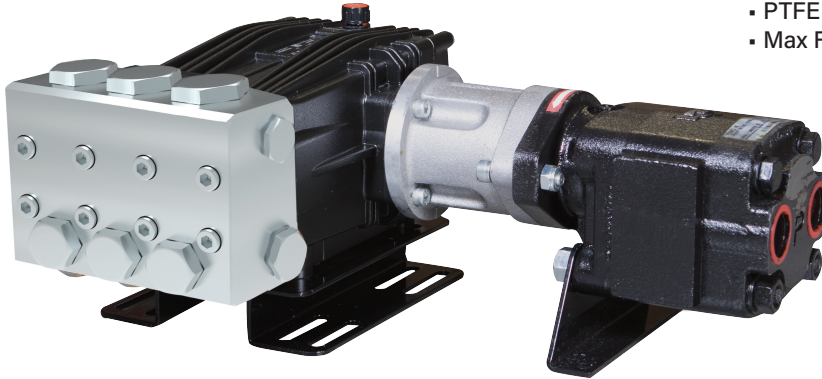

STAINLESS STEEL

Hydraulic Drive Assemblies

Pump, Hydraulic Motor, Mounting Rails
1450 RPM

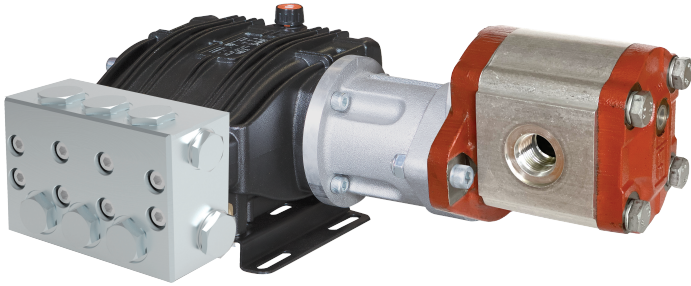

- 316 Stainless Steel Manifolds
- 316 Stainless Steel Valves
- 316 Stainless Steel Plunger Rods & Nuts
- 304 Stainless Steel Exterior Bolts
- Solid Ceramic Plungers
- PTFE Style Packings
- Max Fluid Temp, 160°F

Stainless Steel Hydraulic Drive Assemblies

Stainless steel hydraulic drive plunger pump assemblies include models with flow rates from 4.0 to 5.0 GPM and pressures up to 2900 PSI.

Applications include general pressure cleaning, sewer jetting, vehicle wash equipment and aggressive environment applications.

	Model	GPM	l/min	PSI	bar	Hydraulic Requirements	Weight
1450 RPM	BSC 15/20 SH	4.0	15.0	2900	200	10.0 GPM @ 1700 PSI	39 lbs
	BSC 18/20 SH	4.9	18.5	2900	200	10.0 GPM @ 1900 PSI	39 lbs
	BSC 21/20 SH	5.5	21.0	2900	200	10.0 GPM @ 1900 PSI	39 lbs
	CSC 27/20 SH	7.0	27	3000	200	20.0 GPM @ 2000 PSI	80 lbs
	CSC 34/20 SH	9.0	34	3000	200	20.0 GPM @ 2000 PSI	80 lbs
	CSC 42/17 SH	11.5	42	2500	170	20.0 GPM @ 2200 PSI	80 lbs
	CSC 50/15 SH	13.0	50	2200	150	20.0 GPM @ 2200 PSI	80 lbs



6180 140th Avenue NW
Ramsey, MN 55303

Ph: 651-785-0666
Fax: 800-732-2670

www.udorusa.com
www.boominator.com
info@udorusa.com



Scan this QR Code
for More Information

SS-H
2024A

Hydraulic Drive Assembly **CSC 50/15 SH**

MAX FLOW	13.2 GPM 50 L/MIN
MAX PRESSURE	2200 PSI / 150 BAR
RATED PUMP SPEED	1450 RPM
HYDRAULIC REQUIREMENT	20.0 GPM / 2200 PSI
LUBRICATION	34.5 OZ UDOR LUBE

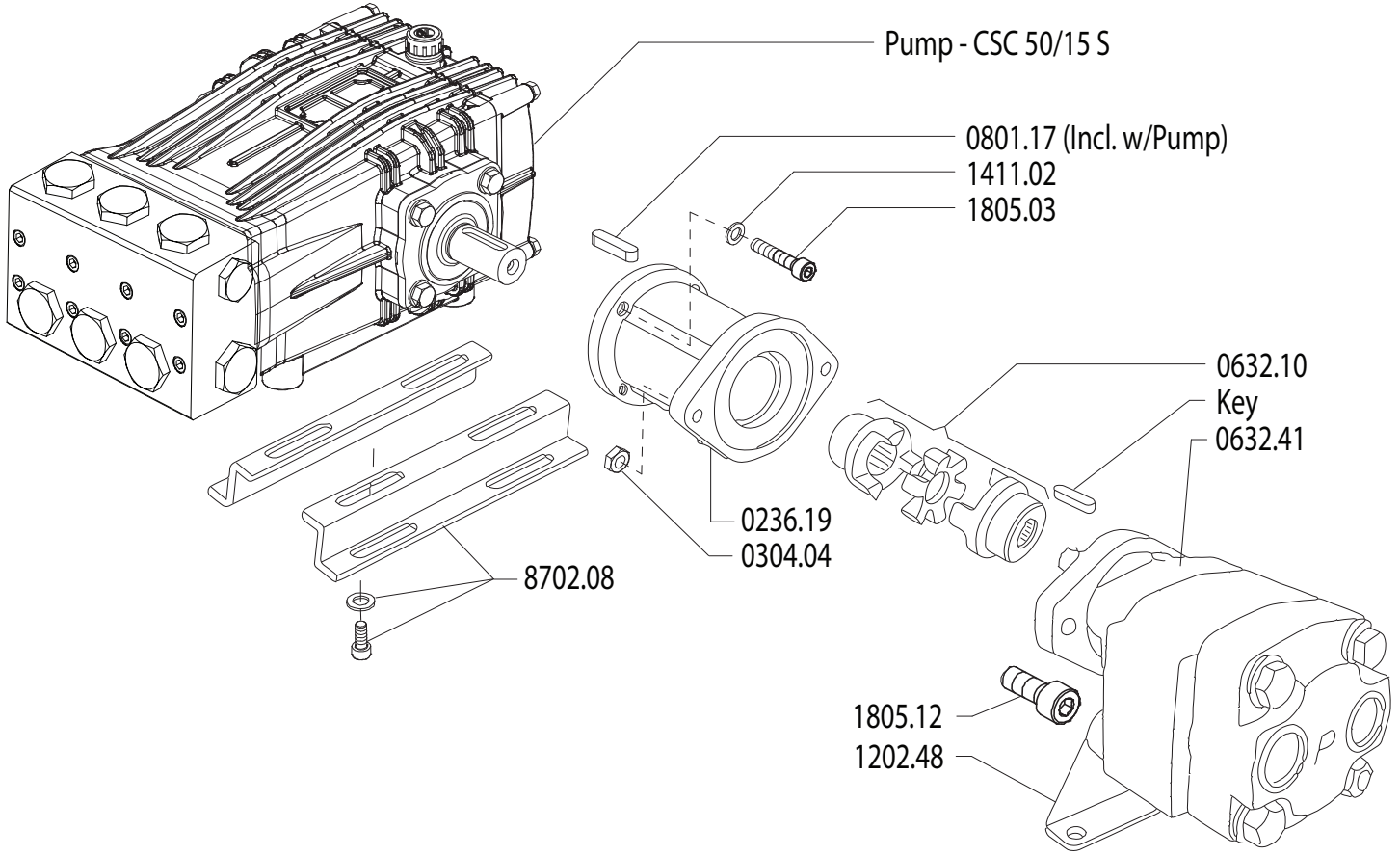

Revised 1-20-2025

Part #	Description	Qty
0236.19	ADAPTER HYDRAULIC MOTOR	1
0304.04	NUT - M10	2
0632.10	COUPLER 24MMX3/4	1
0632.41	HYDRAULIC MOTOR CK	1
1411.02	WASHER - D8	4

Part #	Description	Qty
1411.03	WASHER - D10	2
1805.03	ALLEN BOLT M8X30	4
1805.12	ALLEN BOLT M10X500	2
8702.10	RAIL KIT WITH BOLTS/WASHERS	1

MAX FLOW
MAX PRESSURE
RATED PUMP SPEED
POWER REQUIREMENT
LUBRICATION

13.2 GPM 50 L/MIN
2200 PSI / 150 BAR
1450 RPM
19.5 HP ELECTRIC
34.5 OZ UDOR LUBE

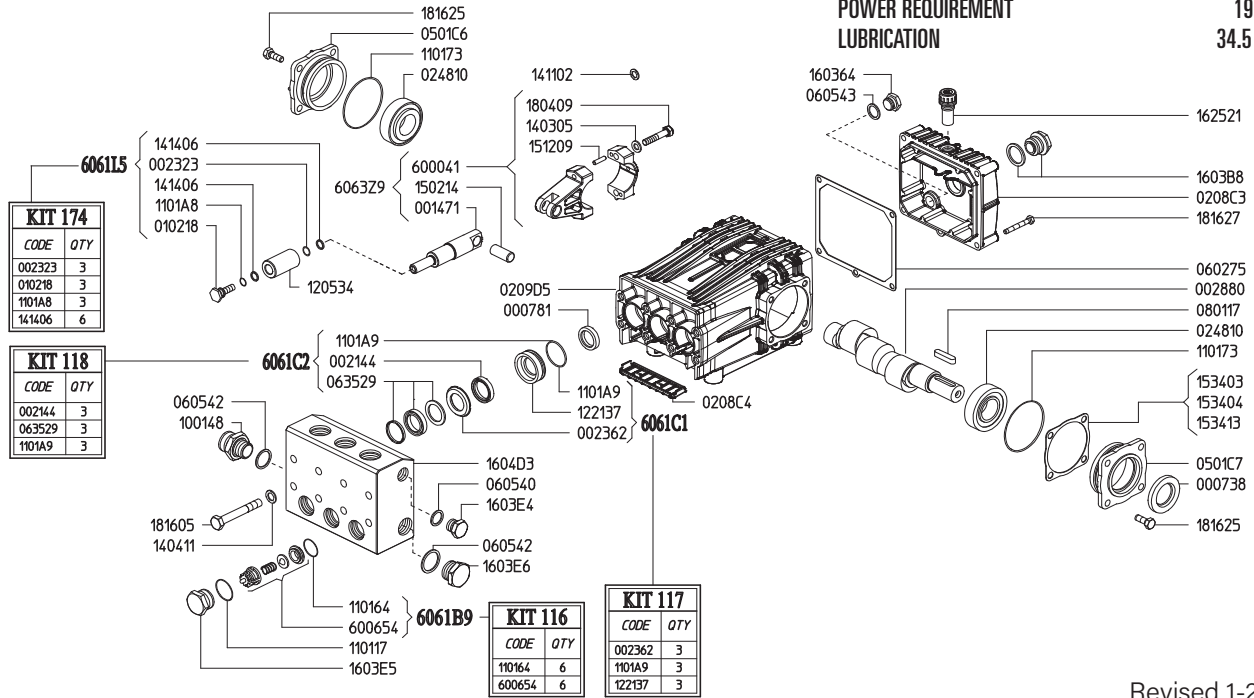

Revised 1-20-2025

Part #	Description	Qty	Part #	Description	Qty
0007.38	OIL SEAL D30	1	1404.11	GROWER WASHER D10.5 SS	8
0007.81	OIL SEAL D20	3	1411.02	SCHNORR WASHER D8	6
0014.71	PLUNGER GUIDE D28 "CS"	3	1414.06	WASHER D13.4 SS ^D	6
0021.44	WATER SEAL L.P. D28 BPE ^C	3	1502.14	PIN D14X32	3
0023.23	RING D10.4 ^D	3	1512.09	PLUG D5X20 UNI1707	6
0023.62	UPPER RING D28 "CS" SS ^B	3	1534.03	SHIM 0.1 MM	-
0028.27	MALE SHAFT D24	1	1534.04	SHIM 0.2 MM	-
0102.18	PLUNGER BOLT SS ^D	3	1534.13	SHIM 0.05 MM	-
0208.C3	BACK COVER "C/CK"	1	1603.64	PLUG G3/8	1
0208.C4	COVER "C/CK"	1	1603.B8	OIL PLUG G3/4 + GASKET	1
0209.D5	CRANKCASE "C/CK/CH/CS"	1	1603.E4	PLUG G1/2 SS	1
0248.10	ROLLER BEARING D30	2	1603.E5	VALVE PLUG "CS" PISTON D28 SS	6
0501.C6	BEARING CLOSED FLANGE	1	1603.E6	PLUG G3/4 SS	1
0501.C7	BEARING HOLLOW FLANGE	1	1604.D3	HEAD "CS" PISTON D28 SS	1
0602.75	BACK COVER GASKET	1	1625.05	OIL PLUG G3/8	1
0605.40	GASKET D21.5	1	1804.09	HEX SCREW M8X40 UNI5737	6
0605.42	GASKET D27	2	1816.05	HEX SCREW M10X90 UNI5737 SS	8
0605.43	GASKET D17	1	1816.25	HEX SCREW M8X20 UNI5739 SS	8
0635.29	HIGH PRESS. SEAL KIT D28 ^C	3	1816.27	HEX SCREW M6X45 UNI5931 SS	5
0801.17	KEY A8X7X35 UNI6604	1	6000.41	ROD ASSEMBLY	3
1001.48	NIPPLE G1" M - G3/4 M	1	6006.54	VALVE ASSY "CS" W/O O-RING ^A	6
1101.17	O-RING D22,23 (RIF.130)	6	6061.B9	VALVE KIT "CS" (KIT 116)	
1101.64	O-RING D20,24 (RIF. 3081) 90SHORE ^A	6	6061.C1	SS RING KIT D28 "CS" (KIT 117)	
1101.73	O-RING D67,95 (RIF.3268)	2	6061.C2	WATER SEAL KIT D28 (KIT 118)	
1101.A8	O-RING D9,25 (RIF.2037) ^D	3	6061.L5	PLUNGER KIT D28 "CS" (KIT 174)	
1101.A9	O-RING D37,77 (RIF.3150) ^{B,C}	3			
1205.34	CERAMIC PLUNGER D28	3			
1221.37	PRESSURE RING D28 "CS" SS ^B	3			
1403.05	WASHER D8.4	6			

^A Parts in 6061.B9 (Kit 116).
^B Parts in 6061.C1 (Kit 117).
^C Parts in 6061.C2 (Kit 118).
^D Parts in 6061.L5 (Kit 174).

WEIGHT
LUBRICATION

39 LBS
34.5 OZ UDOR LUBE

CS SERIES PUMPS 10 GPM & OVER

*Dimensional Drawings are
Shown in Millimeters.
To Convert to Inches,
Multiply Dimension x 0.03937*

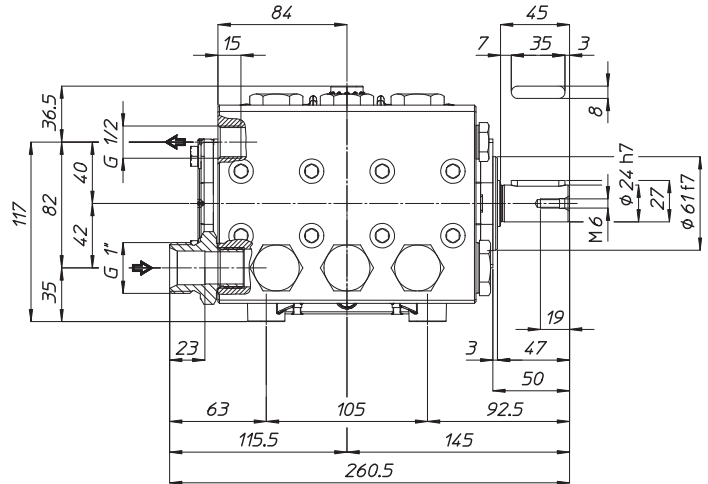
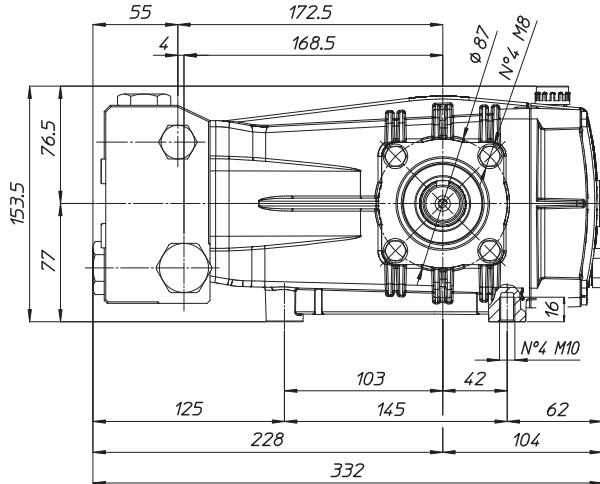

CS SERIES HYDRAULIC DRIVE ASSEMBLIES

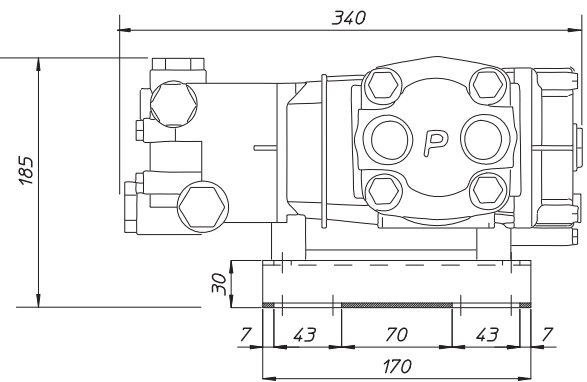
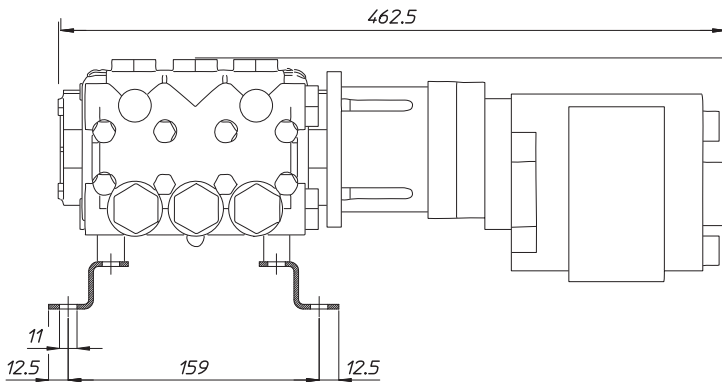

TORQUE SPECS

Ref.	Description	Ft./lb.	Nm	Loctite®
1	Head Bolts	37	50	-
2	Valve Caps	103	140	243
3	Inlet Cap	103	140	-
4	Outlet Cap	103	140	243
5	Bearing Flange Bolts	19	25	-
6	Rear Cover Bolts	8	11	-
7	Connecting Rod Bolts	19	25	270
8	Plunger Bolts	15	20	270
9	Valve Cover Bolts	-	-	-
10	Oil Drain Plug	8	11	-

