

STAINLESS STEEL

Hydraulic Drive Assemblies

Pump, Hydraulic Motor, Mounting Rails
1450 RPM

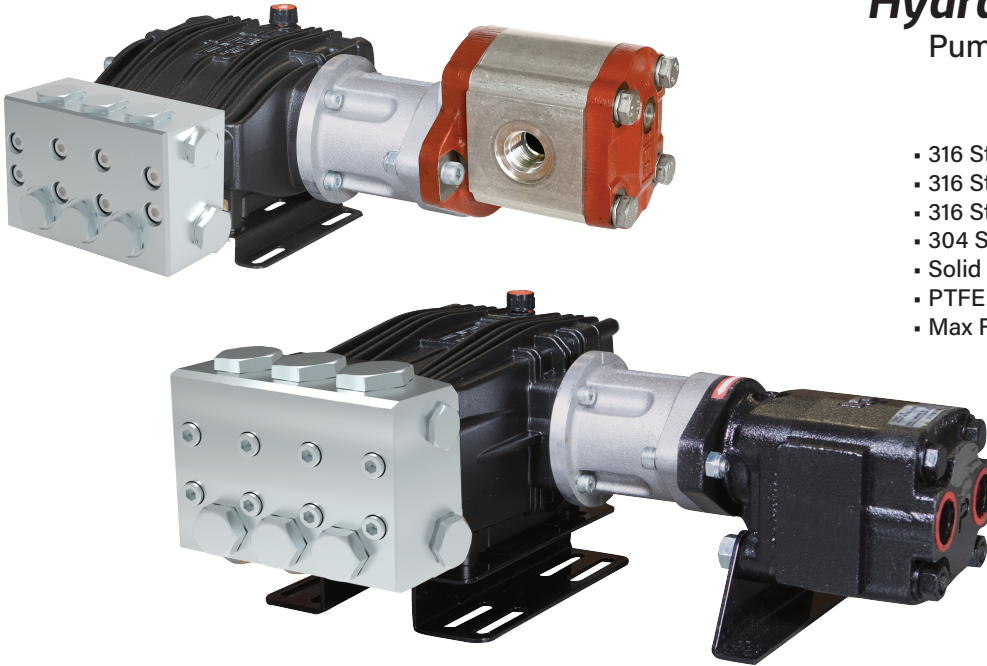

- 316 Stainless Steel Manifolds
- 316 Stainless Steel Valves
- 316 Stainless Steel Plunger Rods & Nuts
- 304 Stainless Steel Exterior Bolts
- Solid Ceramic Plungers
- PTFE Style Packings
- Max Fluid Temp, 160°F

Stainless Steel Hydraulic Drive Assemblies

Stainless steel hydraulic drive plunger pump assemblies include models with flow rates from 4.0 to 5.0 GPM and pressures up to 2900 PSI.

Applications include general pressure cleaning, sewer jetting, vehicle wash equipment and aggressive environment applications.

	Model	GPM	l/min	PSI	bar	Hydraulic Requirements	Weight
1450 RPM	BSC 15/20 SH	4.0	15.0	2900	200	10.0 GPM @ 1700 PSI	39 lbs
	BSC 18/20 SH	4.9	18.5	2900	200	10.0 GPM @ 1900 PSI	39 lbs
	BSC 21/20 SH	5.5	21.0	2900	200	10.0 GPM @ 1900 PSI	39 lbs
	CSC 27/20 SH	7.0	27	3000	200	20.0 GPM @ 2000 PSI	80 lbs
	CSC 34/20 SH	9.0	34	3000	200	20.0 GPM @ 2000 PSI	80 lbs
	CSC 42/17 SH	11.5	42	2500	170	20.0 GPM @ 2200 PSI	80 lbs
	CSC 50/15 SH	13.0	50	2200	150	20.0 GPM @ 2200 PSI	80 lbs



MAX FLOW
 MAX PRESSURE
 RATED PUMP SPEED
 HYDRAULIC REQUIREMENT
 LUBRICATION

5.5 GPM / 21 L/MIN
 3000 PSI / 200 BAR
 1450 RPM
 10.0 GPM / 1900 PSI
 15.4 OZ UDOR LUBE

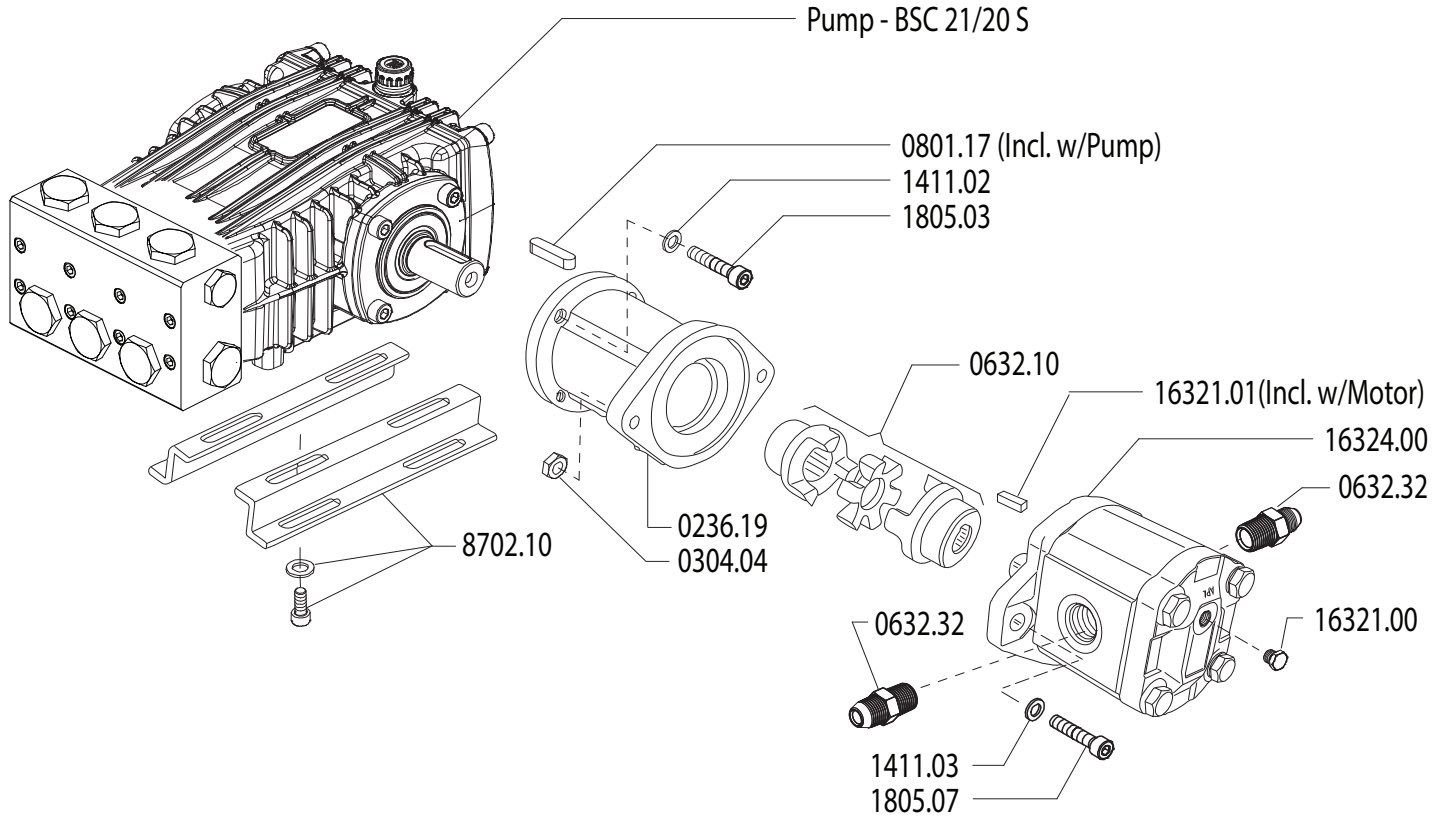

Revised 1-21-2025

Part #	Description	Qty
0236.19	ADAPTER HYDRAULIC MOTOR	1
0304.04	NUT - M10	2
0632.10	COUPLER 24MMX3/4	1
0632.32	HYDRAULIC FITTING	2
1411.02	WASHER - D8	4
1411.03	WASHER - D10	2
1805.03	ALLEN BOLT M8 1.25x30	4

Part #	Description	Qty
1805.07	ALLEN BOLT M10 1.5x40	2
8702.10	RAIL KIT WITH BOLTS/WASHERS	1
16321.00	CASE DRAIN PLUG - #4 ORB	1
16321.01	KEY - 5/32" X 6/32" X 1/2"	1
16322.01	HYDRAULIC MOTOR REPAIR KIT	-
16324.00	HYDRAULIC MOTOR - B/C	1
BSC2120S	PUMP - BSC 21/20 S, 5.5 GPM @ 3000 PSI	1

MAX FLOW
MAX PRESSURE
RATED PUMP SPEED
POWER REQUIREMENT
LUBRICATION

5.5 GPM / 21 L/MIN
3000 PSI / 200 BAR
1450 RPM
11.0 HP ELECTRIC
15.4 OZ UDOR LUBE

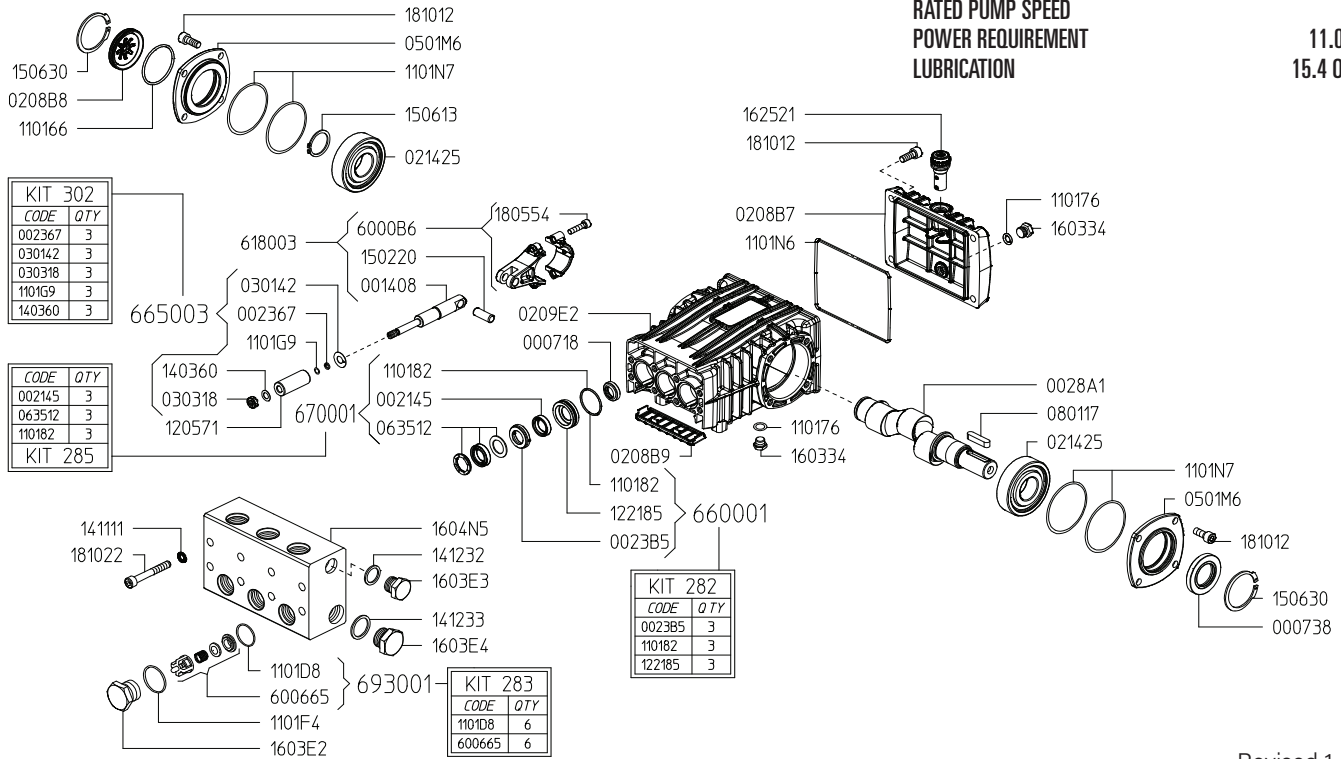

Revised 1-21-2025

Part	Description	Qty	Part	Description	Qty
000718	OIL SEAL	3	1403.60	WASHER D8 ^A	3
000738	OIL SEAL	1	1411.01	SERRATED WASHER	6
0014.08	PLUNGER ROD	3	1411.11	WASHER	8
0021.45	WATER SEAL LP D18 ^B	3	1412.32	GASKET - DISCHARGE PLUG	1
0023.67	RING D5.2X8X1.3 ^A	3	1412.33	GASKET - INLET PLLUG	1
0023.B5	UPPER RING D18 SS ^D	3	14810.12	ALLEN BOLT - SS	4
0028.A1	CRANKSHAFT	1	1502.20	PIN	3
0208.B6	OIL SIGHT GLASS	1	1506.09	SNAP RING	2
0208.B7	BACK COVER	1	1506.13	SNAP RING	1
0208.B9	PLATE	1	1603.34	OIL DRAIN PLUG	2
0209.E2	CRANKCASE	1	1603.E2	VALVE PLUG - SS	6
0214.25	BEARING	2	1603.E3	PLUG - DISCHARGE	1
0301.42	SLINGER RING ^A	3	1603.E4	PLUG - INLET	1
0303.18	NUT M8XH5 ^A	3	1604.N5	HEAD - SS	1
0501.M6	BEARING RETAINER	2	1625.04	OIL PLUG	1
0635.12	HIGH PRESSURE SEAL ASS'Y D18 ^B	3	1810.12	ALLEN BOLT - SS	8
0801.17	KEY	1	1810.22	ALLEN BOLT - SS	8
0805.54	ALLEN BOLT - SS	6	6006.65	VALVE ASSEMBLY W/O O-RING ^C	3
1101.66	O-RING - OIL SIGHT GLASS	1	6006.B6	CONNECTING ROD	3
1101.76	O-RING - OIL DRAIN PLUG	2	6180.03	CONNECTING ROD ASS'Y COMPLETE	3
1101.82	O-RING - PRESSURE RING ^{B,D}	3	6700.01	WATER SEAL KIT (KIT 285)	1
1101.D8	O-RING - VALVE ^C	3	6650.03	PLUNGER BOLT KIT (KIT 302)	1
1101.F4	O-RING - VALVE PLUG	6	6600.01	SS RING KIT (KIT 282)	1
1101.G9	O-RING - PLUNGER ROD ^A	3	6930.01	VALVE KIT (KIT 283)	1
1101.N6	O-RING - BACK COVER	1			
1101.N7	O-RING - BEARING RETAINER	4			
1205.71	CERAMIC PLUNGER D18	3			
1221.85	PRESSURE RING D18 SS ^D	3			

^A Parts in 6650.03 (Kit 302).
^B Parts in 6700.01 (Kit 285).
^C Parts in 6930.01 (Kit 283).
^D Parts in 6600.01 (Kit 282).

*Dimensional Drawings are
Shown in Millimeters.
To Convert to Inches,
Multiply Dimension x 0.03937*

BS SERIES PUMPS - 24MM SOLID SHAFT

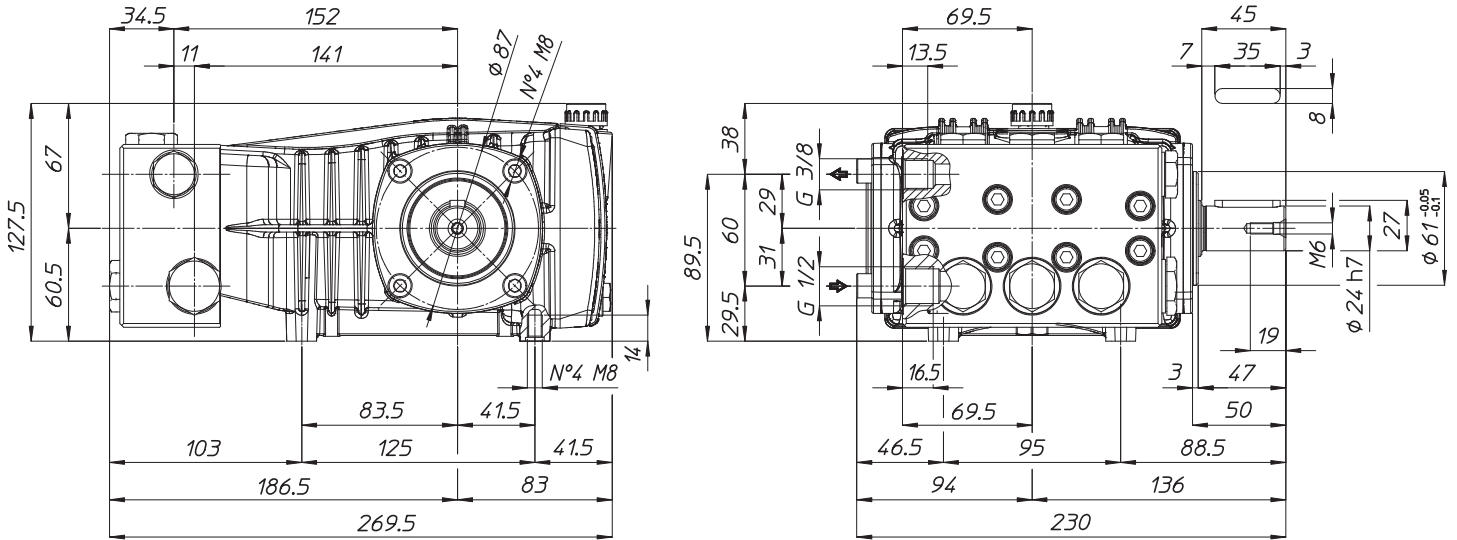

BS SERIES HYDRAULIC DRIVE PUMP ASSEMBLY

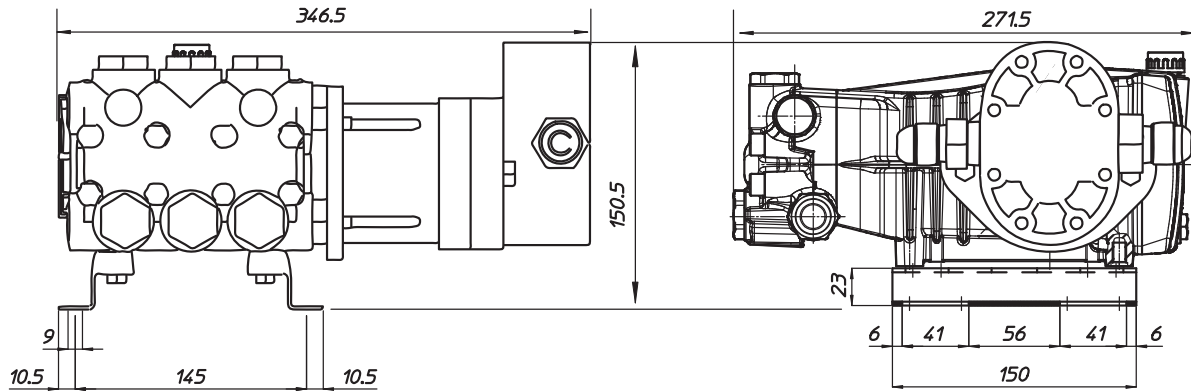

TORQUE SPECS

Ref.	Description	Ft./lb.	Nm	Loctite®
1	Head Bolts	19	25	-
2	Valve Caps	75	100	243
3	Inlet Cap	75	100	243
4	Outlet Cap	60	80	243
5	Bearing Flange Bolts	19	25	-
6	Rear Cover Bolts	19	25	-
7	Connecting Rod Bolts	9	11	243
8	Plunger Bolts	11	15	270
9	Valve Cover Bolts	-	-	-
10	Oil Drain Plug	19	25	-

