

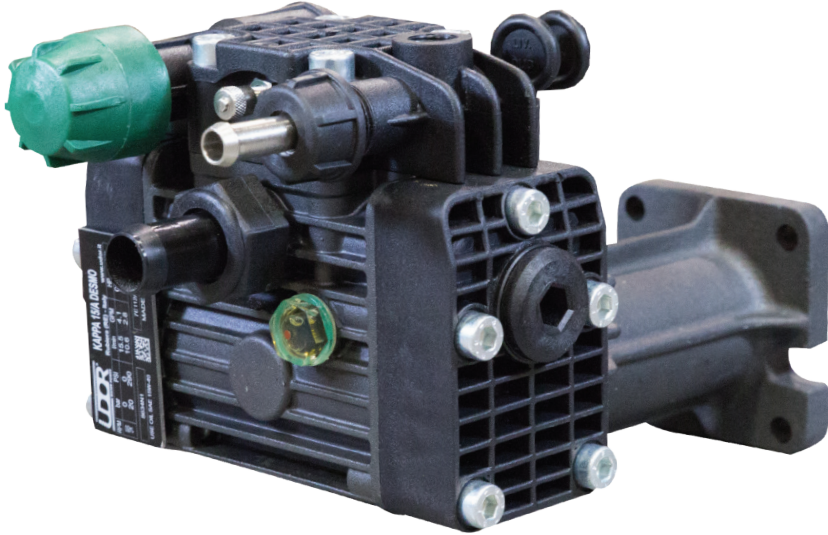

KAPPA 7/15/18

2-Cylinder, Medium-Pressure Diaphragm Pumps



The KAPPA 7DC, 15DC & 18DC are internally manifolded, two diaphragm pumps with pulsation dampener, Anodized aluminum and glass-filled nylon construction. Additional pressure regulator required.

KAPPA 15 GR3/4 pumps include pulsation dampener, adjustable pressure regulator and gearbox for gas engines with 3/4" shaft

Model	GPM	l/min	PSI	bar	RPM	Drive Configuration	Weight
KAPPA 7 DC	2.0	7.6	275	20	1450	Replacement Pump for KAPPA 7 12-Volt	14 LBS
KAPPA 15 DC	3.5	13.3	275	20	1450	Replacement Pump for KAPPA 15 12-Volt	14 LBS
KAPPA 18 DC	4.2	16.0	275	20	1450	Replacement Pump for KAPPA 18 12-Volt	14 LBS
KAPPA 15 GR3/4	3.5	13.3	275	20	1450	Gear Reduction for 3/4" Shaft Gas Engine, 4-6.5 HP	17 LBS

Specifications	KAPPA 7	KAPPA 15	KAPPA 18
Inlet Port			3/4" Hose Barb
Outlet Ports			1/2" Hose Barb
Bypass			5/8" Hose Barb
Piston Diameter			30mm
Dimensions			7"L x 7.5"W x 6.5"H

Description	Part #
Diaphragm Kit (GREENTECH)	8700.27
Diaphragm Bolt & Washer Kit	6062.04
Valve Kit	6062.02
Regulator Repair Kit	6062.A9
Complete Repair Kit	8700.27CK

Lubrication: Requires 4 oz. of Udor Lube 40W Premium Pump Oil.
Alternate Oil: 30W non-detergent or 15W-40 non-detergent oil.



6180 140th Avenue NW
Ramsey, MN 55303

Ph: 651-785-0666
Fax: 800-732-2670

www.udorusa.com
www.boominator.com
info@udorusa.com



Scan this QR Code
for More Information

K71518
2024A

Maximum Flow	2.0 GPM / 7.6 lpm
Maximum Pressure	200 PSI / 15 bar
Maximum RPM	1450 RPM
Inlet Port - Hose Barb	3/4" HB
Outlet Ports - Hose Barb, Valve	1/2" HB
Bypass - Hose Barb	5/8" HB
Dimensions	6.6"L x 7.28"W x 6.02"H
Weight	14 lbs

Lubrication: Requires 4 oz. of Udor Lube 40W Premium Pump Oil.
Alternate Oil: 30W non-detergent or 15W-40 non-detergent oil.

8700.27CK		870027		606201		606202		606204	
KIT 630		KIT 500		KIT 501		KIT 503			
CODE	QTY	CODE	QTY	CODE	QTY	CODE	QTY	CODE	QTY
010202	2	090344	1	090344	1	110178	4	010202	2
030137	2	090305	2	090345	2	606368	4	030137	2
090344	1	110111	2	110111	2				
110106	1	110178	4	110178	4				
110111	2								
110178	4								
606368	4								

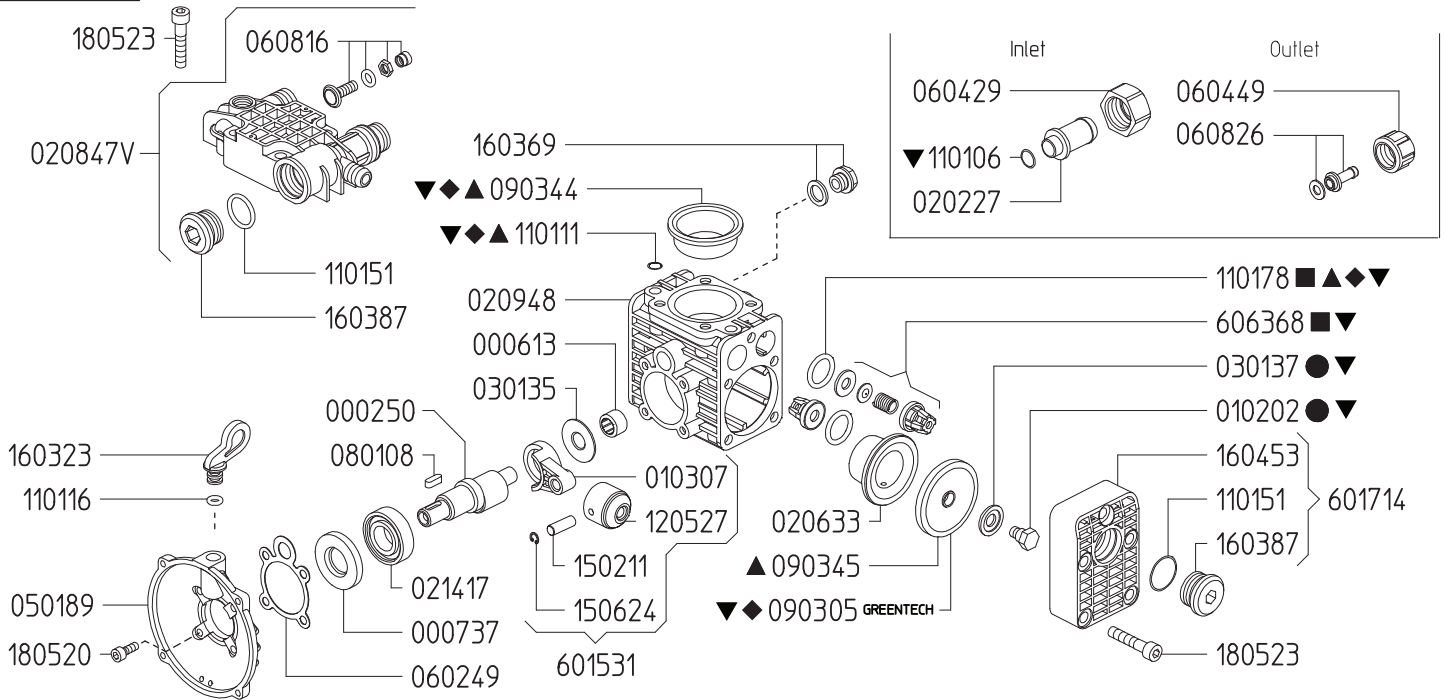

Revised 1-11-2024

Part #	Description	Qty	Part #	Description	Qty
0002.75	SHAFT "KAPPA 15"	1	1101.51	O-RING - PLUG	3
0006.13	BUSHING D12	1	1101.78	O-RING - VALVE▲■◆▼	4
0007.37	OIL SEAL D20V	1	1205.27	ALUMINIUM PISTON D30 "KAPPA 15"	2
0102.02	DIAPHRAGM BOLT "IOTA/KAPPA 15" ●▼	2	1502.11	PIN D8X22	2
0103.07	CONNECTING ROD "KAPPA 15"	2	1506.24	SNAP RING D8	2
0202.27	HOSE BARB D19	1	1603.23	OIL PLUG	1
0206.33	SLEEVE D30 "KAPPA 15"	2	1603.69	OIL PLUG G1/4+GASKET	1
0208.47V	ACCUMULATOR HEAD "KAPPA 12-VOLT"	1	1603.87	PLUG G3/4	3
0209.48	CRANKCASE "KAPPA 15"	1	1604.53	HEAD "KAPPA 15"	2
0214.17	BALL BEARING D20	1	1805.23	ALLEN BOLT M8X40	14
0301.35	BEARING DISC "KAPPA 15"	1	1805.31	ALLEN BOLT M6X30	4
0301.37	DIAPHRAGM DISC "KAPPA 15" ●▼	2	6015.31	ROD ASSY "KAPPA 15" D30	2
0501.89	FLANGE "KAPPA 115-VOLT"	1	6017.14	HEAD ASSY "KAPPA 15"	2
0602.49	GASKET "KAPPA 15"	1	6063.68	VALVE ASSEMBLY W/O O-RING ■▼	4
0604.29	BARB NUT G3/4	1	6062.01	DIAPHRAGM KIT - BUNA (KIT 500)	1
0604.49	BARB NUT G1/2	1	6062.02	IN/OUTLET VALVE KIT (KIT 501)	1
0608.16	AIR VALVE ASSY	1	6062.04	DIAPHRAGM DISC (KIT 503)	1
0608.26	HOSE BARB D13+GASKET	1	8700.27	DIAPHRAGM KIT - GREENTECH (KIT 630)	1
0801.08	KEY A5X5X15 UNI6604-69	1	8700.27CK	COMPLETE REPAIR KIT	1
0903.05	PISTON DIAPHRAGM D56 - GREENTECH ◆▼	2		▲ Parts in 6062.01 (Kit 500).	
0903.44	ACCUMULATOR DIAPH "KAPPA 15" ▲◆▼	1		■ Parts in 6062.02 (Kit 501).	
0903.45	PISTON DIAPHRAGM D56 - BUNA ▲	2		● Parts in 6062.04 (Kit 503).	
1101.06	O-RING - INLET HOSE BARB ▼	1		◆ Parts in 8700.27 (Kit 630).	
1101.11	O-RING - ACCUMULATOR HEAD ▲◆▼	2		▼ Parts in 8700.27CK (Complete Repair Kit).	
1101.16	O-RING - OIL PLUG	1			



KAPPA 7/15/18 DIMENSIONS

All Dimensions are WITHOUT Control Unit or Regulator

Dimensional Drawings are Shown in Millimeters. To Convert to Inches, Multiply Dimension x 0.03937

Specifications	KAPPA 7	KAPPA 15	KAPPA 18
Inlet Port - Hose Barb	3/4" HB	3/4" HB	3/4" HB
Outlet Ports - Hose Barb	1/2" HB	1/2" HB	1/2" HB
Bypass - Hose Barb	5/8" HB	5/8" HB	5/8" HB
Dimensions	7"L x 7.5"W x 6.5"H		
Diaphragm Material	GREENTECH (Std) Buna-N (Opt)		

Lubrication: Requires 4 oz. of Udor Lube 40W Premium Pump Oil.
Alternate Oil: 30W non-detergent or 15W-40 non-detergent oil.

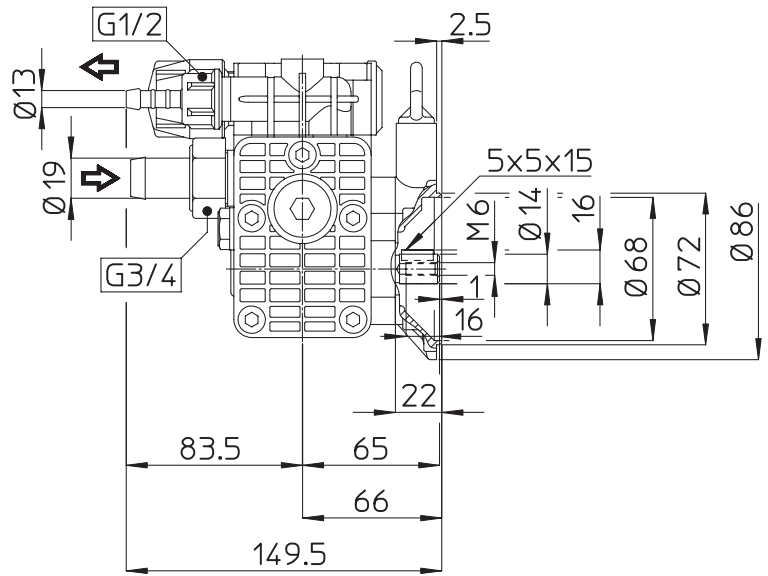
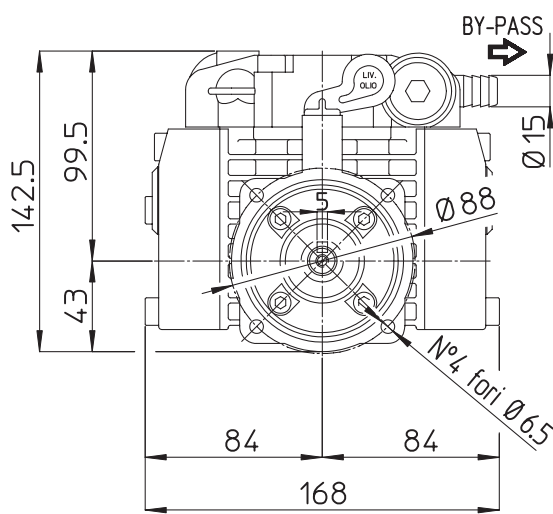

TORQUE SPECS

Ref.	Description	Ft./lb.	Nm
1	Diaphragm Bolts (Use Loctite 243)	10	14
2	Head Bolts	10	14
3	Pulsation Dampener Bolts	10	14
4	Inlet Flange Bolts	-	-
5	Bearing Flange Bolts	7	10
6	Oil Cup Bolts	-	-
7	Valve Cover Bolts	-	-

