



22.901.161 & 22.901.163

High Pressure Adjustable Pattern Spray Gun

Maximum Flow	- 22.901.161	10.0 GPM / 38 lpm
	- 22.901.163	25.0 GPM / 95 lpm
Maximum Pressure		3000 PSI / 200 bar
Inlet	- 22.901.161	3/8" FNPT
	- 22.901.163	1/2" FNPT
Spray Tip	- 22.901.161	1.5 mm
	- 22.901.163	3.0 mm

Revised 4-26-2024

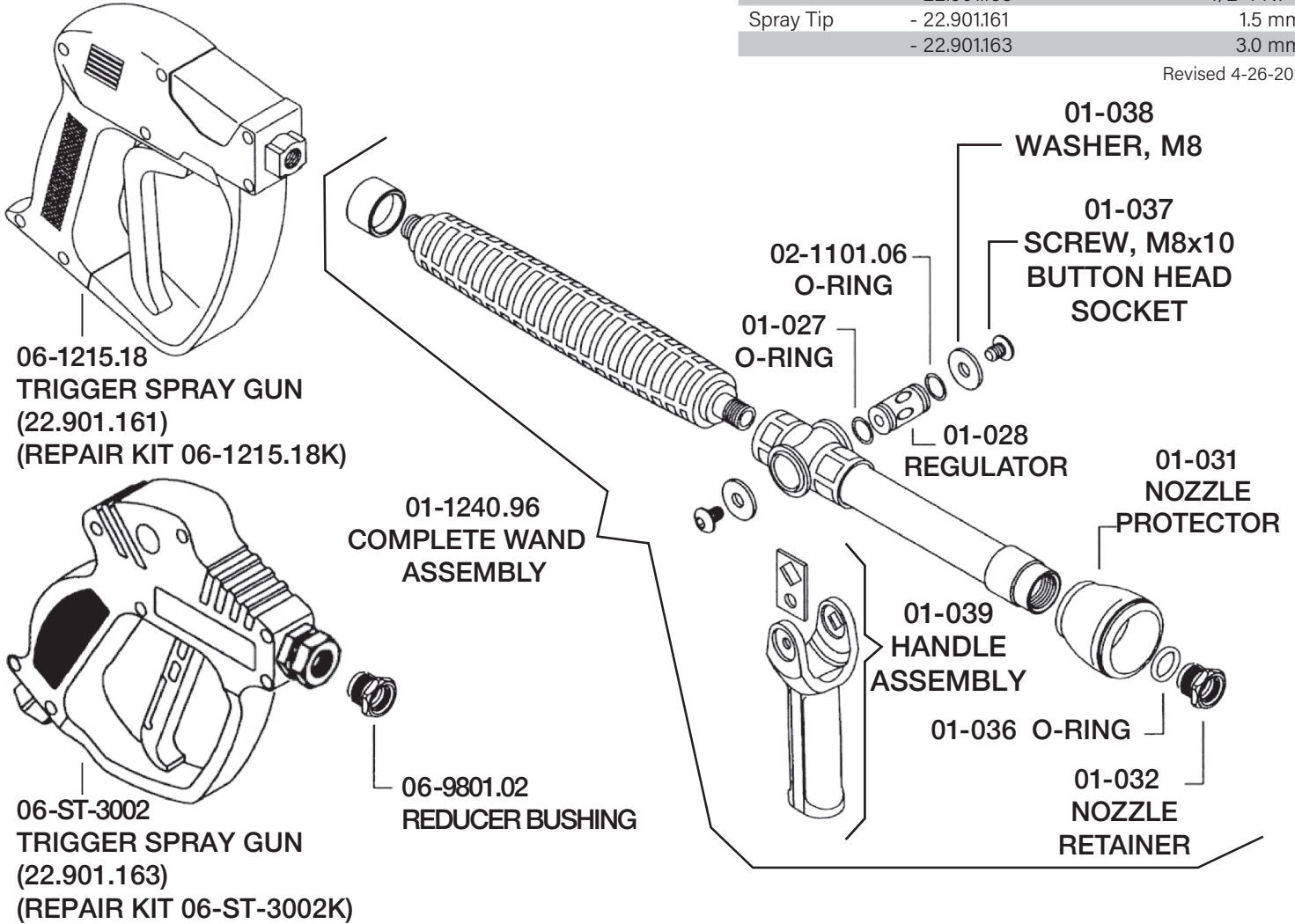

Spray Tip Performance Chart

Model	Orifice (mm)	Material	Gallons per Minute				
			1000 PSI	1500 PSI	2000 PSI	2500 PSI	3000 PSI
68.1802.50	1.2	Ceramic	2.0	2.4	2.6	2.9	3.5
68.1802.51	1.5	Ceramic	2.5	3.0	3.5	3.9	4.4
68.1802.52	1.8	Ceramic	3.5	4.1	4.7	5.3	5.9
68.1802.53	2.0	Ceramic	4.5	5.1	5.8	6.2	6.8
68.1802.54	2.3	Ceramic	6.0	7.0	8.0	9.0	10.0
68.1802.16	2.5	Ceramic	7.5	9.0	10.5	11.5	13.0
68.1802.17	3.0	Ceramic	10.0	12.0	14.0	16.0	18.0
13.1802.73	3.5	S/S	13.0	16.0	19.0	22.0	36.0