

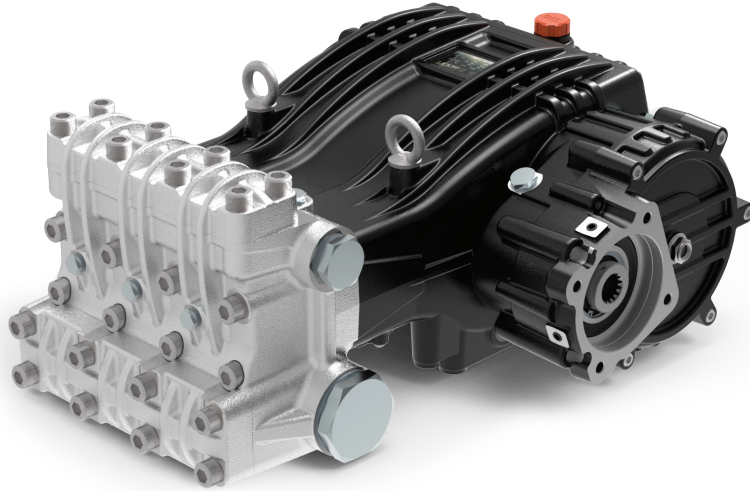

HXR1-C MI SERIES

1.875:1 Gear Reduction Models

50mm Solid Keyed Shaft
1500 RPM



- Anodized Aluminum Crank Case
- Nickel-Plated Manifold
- Stainless Steel Check Valves
- Heavy Duty Bronze Connecting Rods
- Heavy Duty Roller Bearings
- 2-1/2" BSP-F Inlet. 1-1/4" BSP-F Outlet
- Max Fluid Temp, 160°F

HXR MI Series Plunger Pumps

HXR MI Series industrial duty plunger pumps are rated at 32.9 to 104.4 GPM and pressures up to 4350 PSI.

Gear reduction models are available in 1500, 1800 or 2200 RPM models with a 50mm solid, keyed shaft.

Applications include sewer jetting, hydro-excavation, fire fighting, mining and street cleaning.

	Model	Flow		Pressure		Plunger Dia.	Crankshaft		Power	Seal Kit	Valve Kit	Wt.
		GPM	l/min	PSI	bar		Stroke	Code				
1500 RPM	HXR1-C 135/300 R MI	32.9	124.5	4350	300	32mm	70.0mm	35	95.8 EBHP	6700.09	6072.03	367.5 lbs
	HXR1-C 160/240 R MI	42.9	162.5	3480	240	36mm	70.0mm	35	100.0 EBHP	6700.10	6072.03	367.5 lbs
	HXR1-C 210/200 R MI	54.4	206	2900	200	40mm	70.0mm	35	105.7 EBHP	6700.07	6072.13	367.5 lbs
1.875:1 Gear Ratio	HXR1-C 270/160 R MI	68.7	260	2320	160	45mm	70.0mm	35	106.8 EBHP	6700.08	6072.13	367.5 lbs
	HXR1-C 330/130 R MI	86.1	326.0	1885	130	50mm	70.0mm	35	108.7 EBHP	6072.14	6072.13	367.5 lbs
	HXR1-C 400/100 R MI	104.4	395.1	1450	100	55mm	70.0mm	35	101.3 EBHP	6072.16	6072.13	367.5 lbs



6180 140th Avenue NW
Ramsey, MN 55303

Ph: 651-785-0666
Fax: 800-732-2670

www.udorusa.com
www.boominator.com
info@udorusa.com



Scan this QR Code
for More Information

HXR1-C
2024A

HXR1-C 160/240 R MI

MAX FLOW
MAX PRESSURE
RATED PUMP SPEED
POWER REQUIREMENT
LUBRICATION

42.8 GPM / 162 L/MIN
3480 PSI / 240 BAR
800 RPM
100.0 HP ELECTRIC
237 OZ 85W-90 OIL

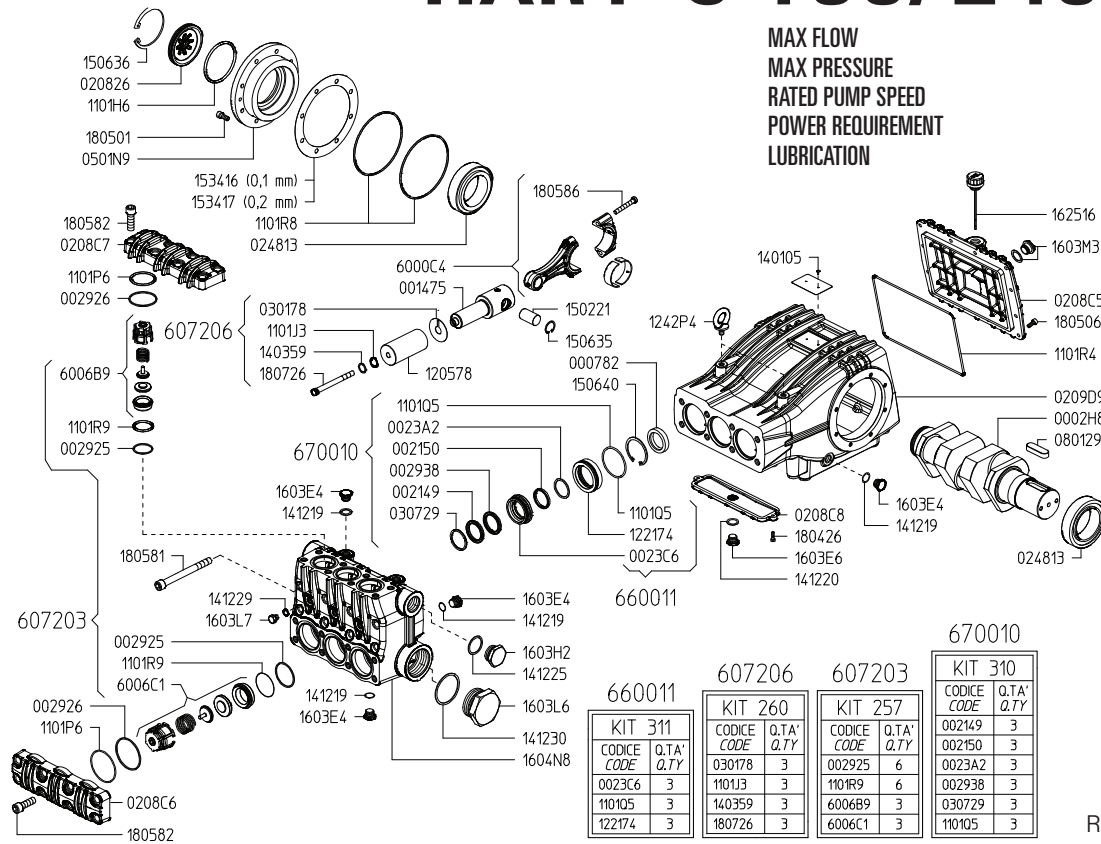

660011		607206		607203		KIT 310	
CODICE	Q.TA' Q.TY	CODICE	Q.TA' Q.TY	CODICE	Q.TA' Q.TY	CODICE	Q.TA' Q.TY
030178	3	030178	3	002925	6	002149	3
0023C6	3	1101J3	3	1101R9	6	002150	3
110105	3	140359	3	6006B9	3	0023A2	3
122174	3	180726	3	6006C1	3	002938	3
						030729	3
						110105	3

Revised 2-2-2024

Part #	Description	Qty
0002.H8	PUMP CRANCKSHAFT	1
0007.82	D40 VITON SHAFT SEAL	3
0014.75	PLUNGER GUIDE	3
0021.49	HIGH PRESSURE SEAL RING D36 ^B	6
0021.50	LOW PRESSURE SEAL RING D36 ^B	3
0023.A2	SCRAPER RING D36 ^B	3
0023.C6	UPPER RING D36 ^C	3
0029.25	ANTI EXTRUSION RING ^A	6
0029.26	ANTI EXTRUSION RING	6
0029.38	ANTI EXTRUSION RING ^B	3
0105.03	BUSHING	3
0208.26	OIL LEVEL SIGHT GLASS	1
0208.C5	REAR COVER	1
0208.C6	VALVE COVER	1
0208.C7	VALVE COVER	1
0208.C8	INFERIOR COVER	1
0209.D9	CRANCKCASE	1
0248.13	BEARING	2
0301.78	SEPARATING DISC	3
0307.29	RING D36 ^B	3
0501.N9	CLOSED BEARING FLANGE	1
0801.29	KEY A22X14X70 UNI6604-A	1
1101.H6	OR D47,29X2,62 RIF 3187	1
1101.J3	OR D10,78X2,62 RIF 3043 90SHORE ^D	3
1101.P6	OR D57,15X3,53 RIF 161	6
1101.Q5	OR D75,79X3,53 RIF 4300 ^{B C}	3
1101.R4	OR D275,00x4,00 RIF 2750-40	1
1101.R8	OR D158,3x3,53 RIF 4625	2
1101.R9	OR D44,04X3,53 RIF 4175 90SHORE ^A	6
1205.78	PISTON D36	3
1221.74	PRESSURE RING D36 ^C	3
1242.P4	M12 UNI-ISO3266 ZINC PLATED EYEBOLT	2
1403.59	WASHER ^D	3

Part #	Description	Qty
1412.19	BONDED SEAL G1/2"	10
1412.20	BONDED SEAL G3/4"	1
1412.25	BONDED SEAL G1"	1
1412.29	BONDED SEAL G1/4"	3
1412.30	BONDED SEAL G2"	1
1502.21	PIN	3
1506.35	SNAP RING D28 UNI7437	6
1506.36	SNAP RING D55 UNI7437 INOX	1
1506.40	SNAP RING D72 UNI7437	3
1534.16	SHIM 0,1mm	1
1534.17	SHIM 0,2mm	1
1603.E4	INOX PLUG G1/2"	10
1603.E6	INOX PLUG G3/4"	1
1603.H2	INOX PLUG G1"	1
1603.L6	INOX PLUG G2"	1
1603.L7	INOX PLUG G1/4"	3
1603.M3	OIL LEVEL SIGHT GLASS G3/4"	1
1604.N8	PUMP HEAD "HX-HP"	1
1625.16	OIL VENT PLUG G3/4"	1
1804.26	HEX SCREW M6X20 UNI 5739 ZINC PLATED	2
1805.01	SOCKET HEAD SCREW M10X25 UNI5931 ZINC PLATED	8
1805.06	SOCKET HEAD SCREW M8X20 UNI5931 ZINC PLATED	12
1805.81	SOCKET HEAD SCREW M18X180 UNI5931 12.9 GEOMET	8
1805.82	SOCKET HEAD SCREW M18X60 UNI5931 12.9 GEOMET	16
1805.86	HEX SCREW M10X65	6
1807.26	HEX SCREW M12X130 DIN6921 INOX ^D	3
6000.C4	PISTON ROD SUBASSEMBLY	3
6006.B9	VALVE SUBASSEBLY ^A	3
6006.C1	VALVE SUBASSEBLY ^A	3
^A 6072.03	KIT 257	
^B 6700.10	KIT 310	
^C 6600.11	KIT 311	
^D 6072.06	KIT 260	

RH115 MI GEAR REDUCER

1.875:1 PTO GEAR REDUCTION

for HXR1-C ___ / ___ R MI PUMPS

REQUIRES 101 OZ. 85W-90 GEAR LUBE

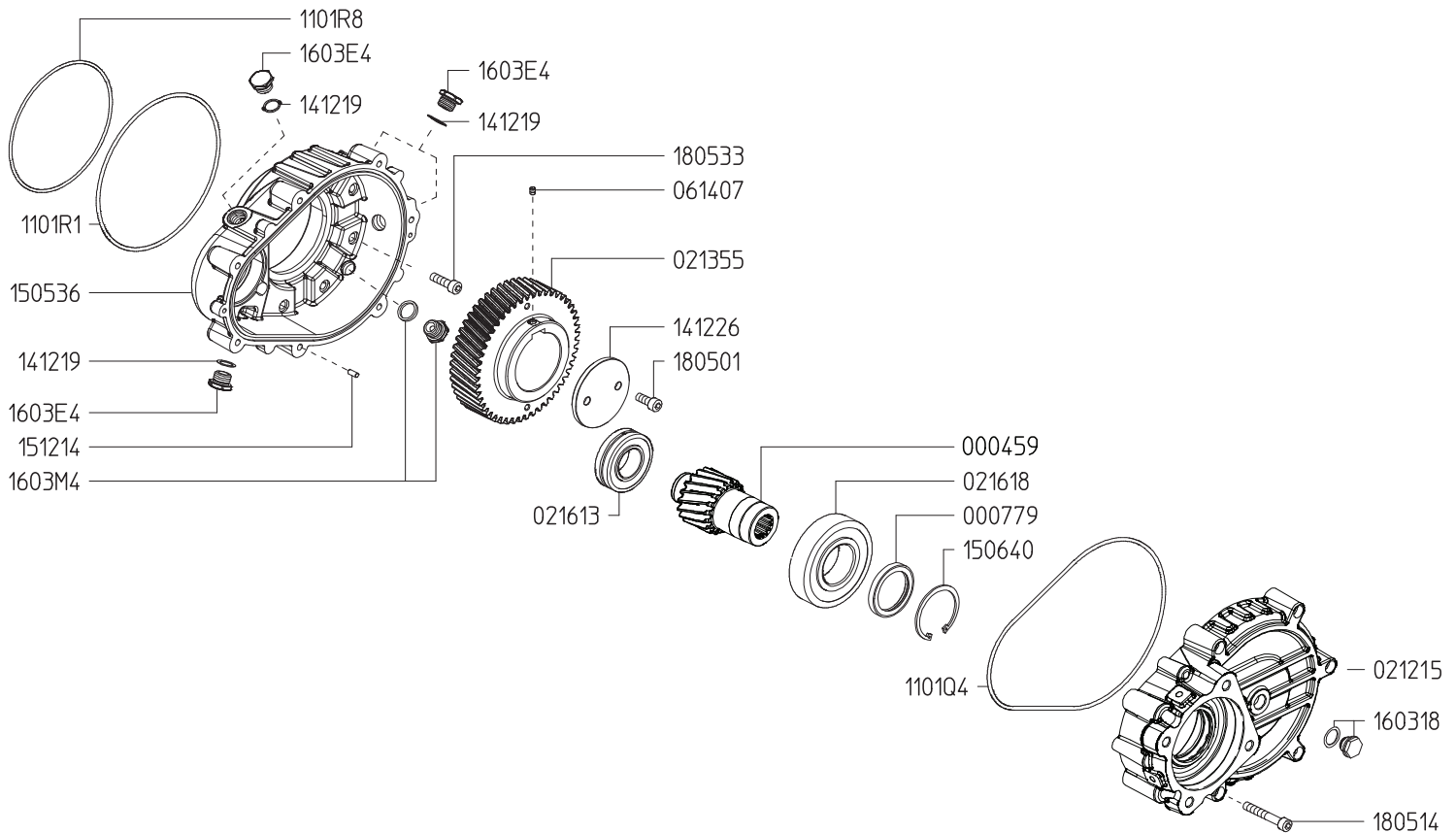

Revised 2-2-2024

Part #	Description	Qty	Part #	Description	Qty
0004.59	PINION "RH 115 MI"	1	1412.19	BONDED SEAL G1/2"	4
0007.79	SHAFT SEAL D55 VITON	1	1505.36	GEARBOX CASE	1
0212.15	GEARBOX COVER - MI	1	1506.40	SNAP RING D72 UNI7437 ZINC PLATED	1
0213.55	GEAR "RH 115"	1	1512.14	CYLINDRICAL PIN D6,0X14 UNI-EN 28734	2
0216.13	BEARING	1	1603.18	OIL LEVEL SIGHT GLASS PLUG G1/2"	1
0216.18	BEARING	1	1603.E4	INOX PLUG G1/2"	4
0614.07	SOCKET SET SCREW M8X10 UNI5929	1	1603.M4	MAGNETIC PLUG G1/2"	1
1101.R1	OR D209,15X3,53 RIF 4825	1	1805.01	SOCKET HEAD SCREW M10X25 UNI5931 ZINC PLATED	2
1101.Q4	OR D266,30X3,53 RIF 41050	1	1805.33	SOCKET HEAD SCREW M10X35 UNI5931 ZINC PLATED	8
1101.R8	OR D158.3x3.53 RIF 4625	1	1805.14	SOCKET HEAD SCREW M10X60 UNI5931 ZINC PLATED	7
1412.26	WASHER	1			



HXR SERIES DIMENSIONS

HXR-MI SERIES PUMPS - 14T 12/24 DP SAE C SHAFT

WEIGHT
LUBRICATION - PUMP
- GEARBOX

411.5 LBS
237 OZ 85W-90 OIL
101 OZ 85W-90 OIL

**Dimensional Drawings are
Shown in Millimeters.
To Convert to Inches,
Multiply Dimension x 0.03937**

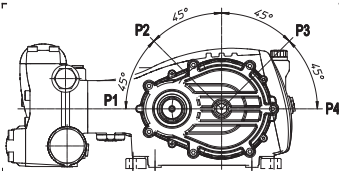

Depending on specific needs, the Gearbox can be mounted in four different positions P1,P2,P3,P4 as shown in the picture at left.

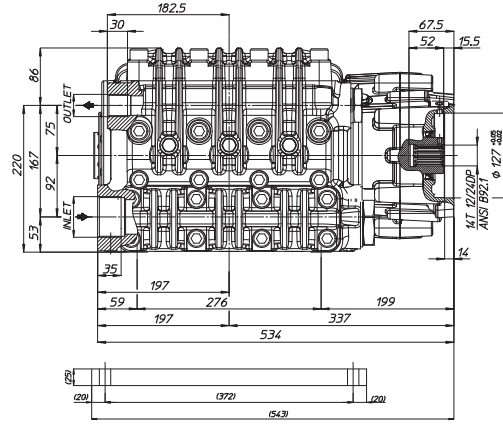
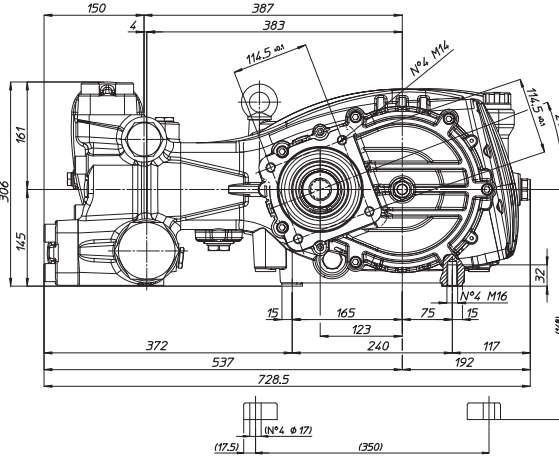

	INLET	OUTLET
135/300 R MI	G 2"	G 1"
160/240 R MI	G 2"	G 1"

	INLET	OUTLET
210/200 R MI	G 2" 1/2	G 1" 1/4
270/160 R MI	G 2" 1/2	G 1" 1/4
330/130 R MI	G 2" 1/2	G 1" 1/4
400/100 R MI	G 2" 1/2	G 1" 1/4

TORQUE SPECS

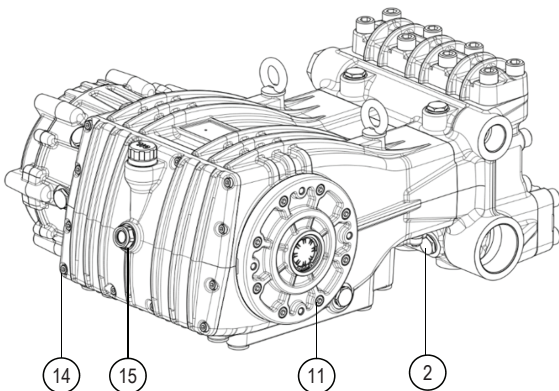
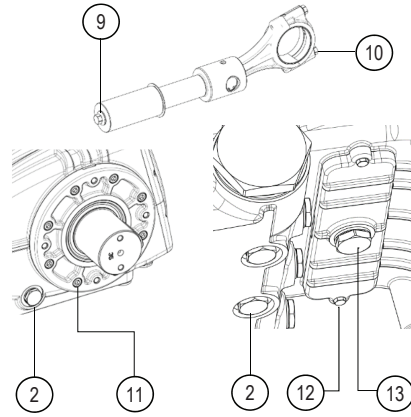
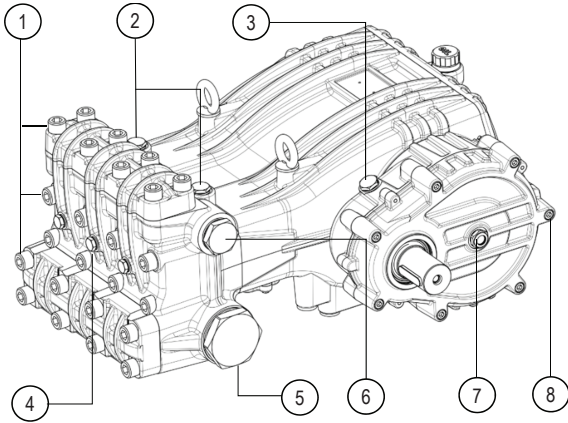

Position	Description	Torque	
1	Head M18 screw Valve cover M18 screw	450 Nm	332 ft/lb
2	Plug G1/2"	100 Nm	74 lb/ft
3	Plug G1/2" 74 lb/ft Magnetic plug G1/2"	100 Nm	74 lb/ft
4	Plug G1/4"	50 Nm	37 lb/ft
5	Plug G2" Plug G2"-1/2	250 Nm	184.4 lb/ft
6	Plug G1"-1/4 74 lb/ft Plug G1"	250 Nm	184.4 lb/ft
7	Oil level sight glass G1/2"	25 Nm	18.4 lb/ft
8	Screw M10	50 Nm	37 lb/ft
9	Screw M12	50 Nm	37 lb/ft
10	Screw M10	50 Nm	37 lb/ft
11	Screw M10	50 Nm	37 lb/ft
12	Screw M6	11 Nm	8.1 lb/ft
13	Plug G3/4"	100 Nm	74 lb/ft
14	Screw M8	25 Nm	18.4 lb/ft
15	Oil level sight glass G3/4"	25 Nm	18.4 lb/ft