

3-Cylinder, Low-Pressure Diaphragm Pumps

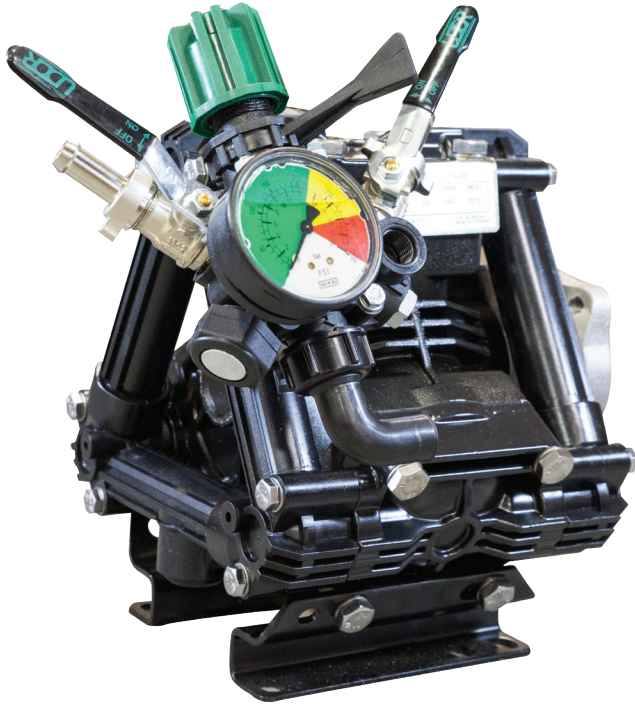

ZETA 85 low pressure 3-cylinder diaphragm pumps have anodized aluminum bodies with plasticized aluminum heads, stainless steel valves and glass-filled nylon manifolds. A control valve with pressure gauge is standard on all models.

ZETA pumps are excellent for various horticultural and agricultural spraying applications.

Pumps are available with Universal VA Drive Face or gear reductions for 4 to 6.5 HP gas engines.

Model	GPM	l/min	PSI	bar	RPM	Drive Configuration	Weight
ZETA 85 VA	22.0	85	300	20	550	Universal VA Drive Face.	29 LBS
ZETA 85 VAGR3/4	22.0	85	300	20	550	Gear Reduction for 3/4" Shaft Gas Engine, 4-6.5 HP	36 LBS

Specifications	ZETA 40
Inlet Port	1-1/2" Hose Barb
Outlet Ports - Valve	(2) 1/2" Hose Barb
Bypass	3/4" Hose Barb
Piston Diameter	60.0mm
Crankshaft Stroke/Code	18.0mm / A
Dims. - Pump Only	11"L x 11"W x 12"H
- GR Version	16"L x 11"W x 12"H

Description	Part #
Diaphragm Kit - GREENTECH	6062.97
Diaphragm Bolt & Washer Kit	6062.48
Valve Kit	6062.D8
Regulator Repair Kit	6062.A9
Complete Repair Kit	8700.60CK

Lubrication: Requires 39 oz. of Udor Lube 40W Premium Pump Oil.
Alternate Oil: 30W non-detergent or 15W-40 non-detergent oil.



Maximum Flow	22 GPM / 85 lpm
Maximum Pressure	300 PSI / 20 bar
Maximum RPM	550 RPM
Inlet Port - Hose Barb	1-1/2" HB
Outlet Ports - Hose Barb, Valve	(2) 1/2" HB
Bypass - Hose Barb	3/4" HB
Dimensions - ZETA 85 VA	11"L x 11"W x 12"H
Weight - ZETA 85 VA	29 lbs

Lubrication: Requires 39 oz. of Udor Lube 40W Premium Pump Oil.
Alternate Oil: 30W non-detergent or 15W-40 non-detergent oil.

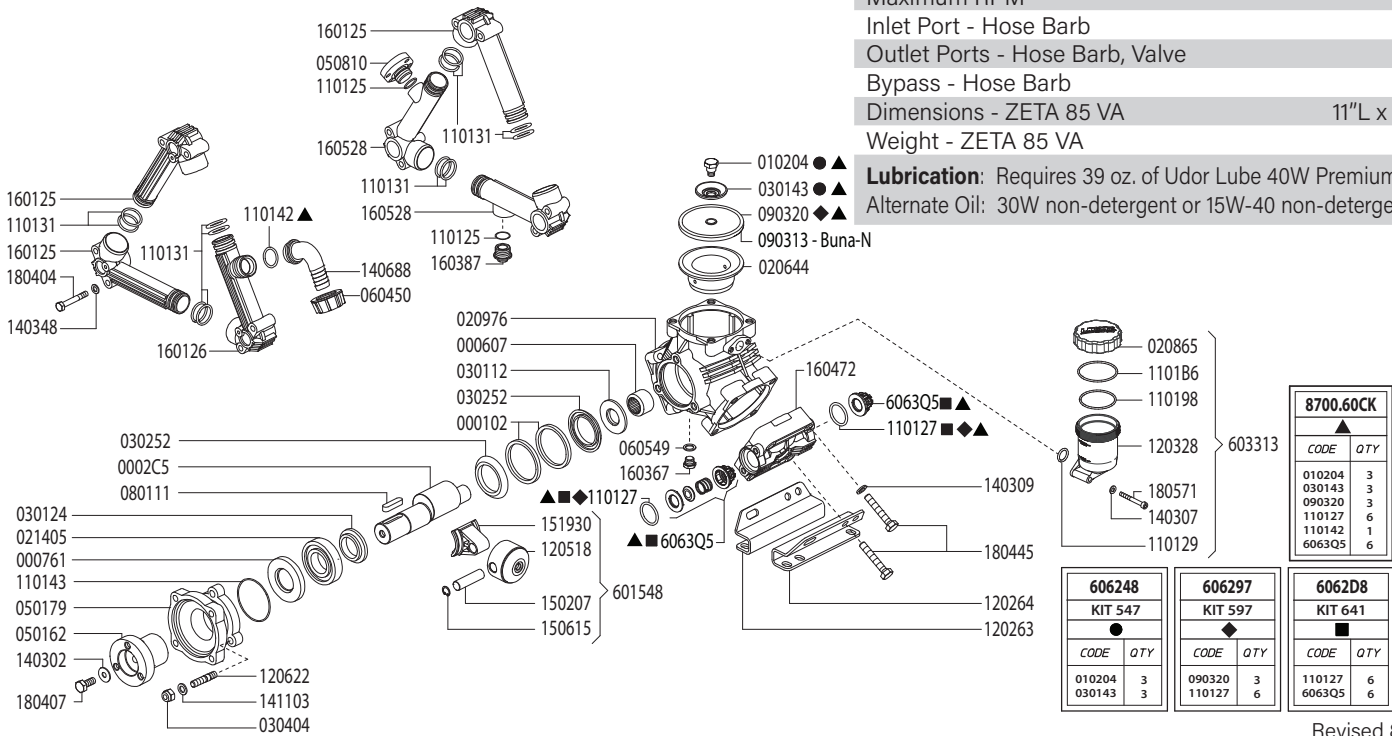

8700.60CK	
CODE	QTY
010204	3
030143	3
090320	3
110127	6
110142	1
6063Q5	6

606248 KIT 547	
CODE	QTY
010204	3
030143	3

606297 KIT 597	
CODE	QTY
090320	3
110127	6

6062D8 KIT 641	
CODE	QTY
110127	6
6063Q5	6

Revised 8-29-2024

Part #	Description	Qty	Part #	Description	Qty
0001.02	RETAINER RING	2	1205.18	ALUMINUM PISTON D60	3
0002.C5	CRANKSHAFT	1	1206.22	STUD M10X46	3
0006.07	BEARING D25	1	1403.02	WASHER M10	3
0007.61	OIL SEAL D35	1	1403.07	WASHER M8	2
0102.04	DIAPHRAGM BOLT ●▲	3	1403.09	WASHER M10	8
0206.44	PISTON SLEEVE D60	3	1403.48	WASHER M8	12
0208.65	OIL RESERVIOR CAP	1	1406.88	SUCTION HOSE BARB 1-1/2"	1
0209.76	CRANKCASE	1	1411.03	SERATED WASHER M10	3
0214.05	BALL BEARING D35	1	1502.07	CONNECTING ROD PIN 15X54	3
0301.12	BEARING DISC D25	1	1506.15	SNAP RING D15	3
0301.24	BEARING DISC D35	1	1519.30	CONNECTING ROD	3
0301.43	DIAPHRAGM WASHER ●▲	3	1601.25	INLET/OUTLET MANIFOLD TUBE	3
0302.52	ROD SPACER	2	1601.26	SUCTION MANIFOLD TUBE G1-1/2" M	1
0304.04	NY-LOCK NUT M10	3	1603.67	OIL PLUG G1/4"	1
0501.62	ADAPTER - VA	1	1603.87	MANIFOLD PLUG G3/4"	2
0501.79	FLANGE - VA	1	1604.72	HEAD	3
0508.10	REGULATOR MOUNTING ADAPTER	1	1605.28	DISCHARGE MANIFOLD TUBE G3/4" F	2
0604.50	BARB NUT G1-1/2"	1	1804.04	HEX BOLT M8X55	12
0605.49	OIL PLUG GASKET	1	1804.07	HEX BOLT M10X25	1
0801.11	KEY 10X8X40	1	1804.45	HEX BOLT M10X60	12
0903.13	PISTON DIAPHRAGM 100mm,BUNA-N	3	1805.71	ALLEN BOLT M6X50	2
0903.20	PISTON DIAPHRAGM 100mm,GREENTECH ◆▲	3	6015.48	PISTON / ROD ASSEMBLY D60	3
1101.25	O-RING - PLUG & ADAPTER	2	6033.13	OIL RESERVIOR ASSEMBLY	1
1101.27	O-RING - VALVE ◆◆▲	6	6063.Q5	VALVE ASSEMBLY W/O O-RING ■▲	6
1101.29	O-RING - OIL RESERVIOR	1	6062.48	DIAPHRAGM WASHER/BOLT (KIT 547)	1
1101.31	O-RING - MANIFOLD	12	6062.97	DIAPHRAGM KIT - GREENTECH (KIT 597)	1
1101.42	O-RING - INLET BARB▲	1	6062.D8	INLET/OUTLET VALVE KIT (KIT 641)	1
1101.43	O-RING - FLANGE	1	8700.60CK	COMPLETE REPAIR KIT	1
1101.98	O-RING - OIL RESERVIOR	1			
1101.B6	O-RING - OIL RESERVIOR	1			
1202.63	MOUNTING RAIL - RIGHT SIDE	1			
1202.64	MOUNTING RAIL - LEFT SIDE	1			
1203.28	OIL RESERVIOR	1			

- Parts in 6062.48 (Kit 547)
- ◆ Parts in 6062.97 (Kit 597).
- Parts in 6062.D8 (Kit 641).
- ▲ Parts in 8700.60CK

Adjustable Pressure Regulator

Maximum Flow	27.0 GPM / 102 lpm
Maximum Pressure	350 PSI / 24 bar
Inlet Port - Hose Barb	-
Outlet Ports - Hose Barb, Valve	(2) 1/2" HB
Bypass - Hose Barb	3/4" HB

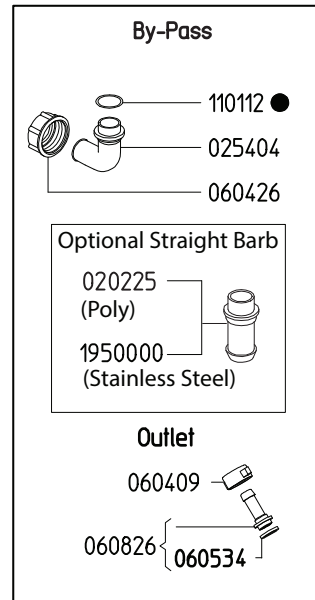
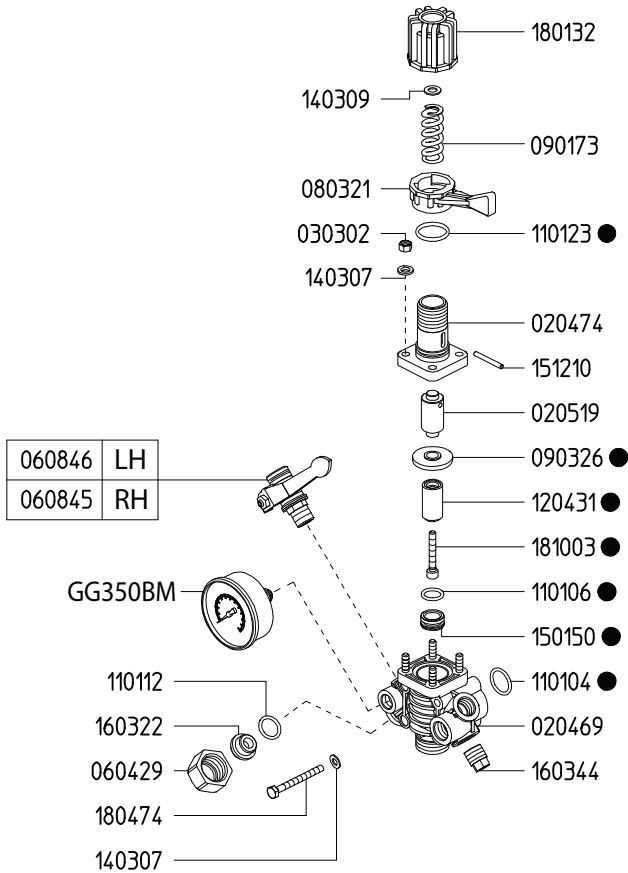

6062A9	
KIT 608	
CODE	QTY
090326	1
110104	1
110106	1
110112	1
110123	1
120431	1
150150	1
181003	1

Revised 8-29-2024

Part #	Description	Qty
0202.25	BYPASS HOSE BARB - STRAIGHT (OPTIONAL)	1
0204.69	BODY	1
0204.70	BODY	1
0205.19	CYLINDER	1
0254.04	BYPASS HOSE BARB - ELBOW	1
0303.02	NUT	4
0604.09	BARB NUT	2
0604.26	BYPASS BARB NUT	1
0604.29	NUT	1
0605.34	GASKET	2
0608.26	1/2" HOSE BARB W/GASKET	2
0608.45	BALL VALVE - RIGHT	1
0608.46	BALL VALVE - LEFT	1
0803.21	LEVER	1
0901.73	SPRING (LP 300 PSI)	1
0903.26	DIAPHRAGM ●	1
1101.04	O-RING ●	1

Part #	Description	Qty
1101.06	O-RING ●	1
1101.12	O-RING ●	2
1101.23	O-RING ●	1
1204.31	POPPET ●	1
1403.07	WASHER	6
1501.50	SEAT ●	1
1512.10	PIN	1
1603.22	PLUG	1
1603.44	PLUG	1
1801.32	ADJUSTMENT KNOB	1
1804.74	BOLT	2
1810.03	STAINLESS STEEL BOLT ●	1
19500.00	BYPASS HOSE BARB - STRAIGHT, SS (OPTIONAL)	1
6062.A9	REPAIR KIT FOR 6010.9X CONTROL UNIT (KIT 608)	1
GG350BM	PRESSURE GAUGE - 350 PSI BACK MOUNT	1

● Parts Included in Repair Kit #6062.A9 (KIT 608)

The control unit features a manual dump valve, pressure control knob, glycerine filled pressure gauge, and two ball valve discharge ports.

1. Before operating or re-operating the pump move lever (0803.21) to the dump position (Right) so the pump will start at zero pressure. (Failure to do so will void the pump warranty.)
2. Turn pressure adjustment knob (1801.32) counter clockwise to relieve spring tension. This step only applies to the initial start up and is not necessary in daily operation of pump.
3. Start unit and let run until air is evacuated from the system.
4. Move lever (0803.21) to the pressure position (Left) open spray gun or spray boom and turn the pressure adjustment knob (1801.32) clockwise until desired operating pressure is achieved.

ZETA 40/85 DIMENSIONS

All Dimensions are WITHOUT Control Unit or Regulator

Dimensional Drawings are Shown in Millimeters. To Convert to Inches, Multiply Dimension x 0.03937

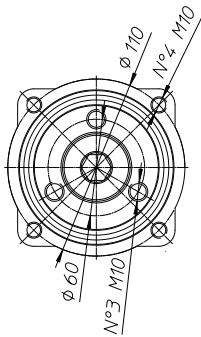
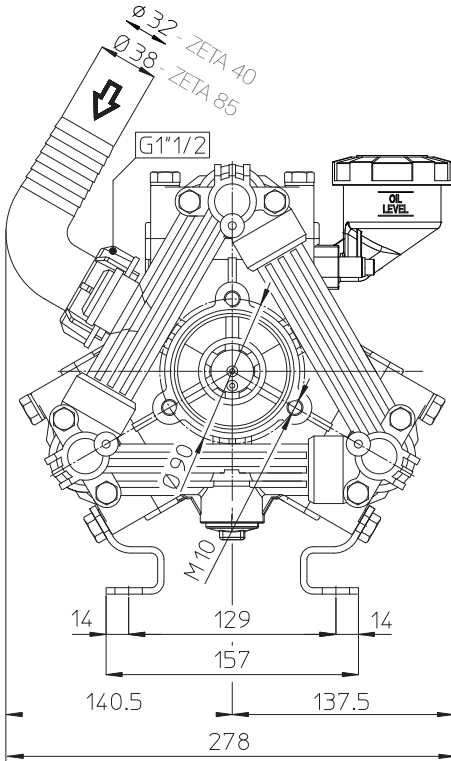

Specifications	ZETA 40	ZETA 85
Inlet Port - Hose Barb	1" HB	1-1/2" HB
Outlet Ports - Hose Barb, Valve	(2) 1/2" HB	(2) 1/2" HB
Bypass - Hose Barb	3/4" HB	3/4" HB
Dimensions - Pump Only	11"L x 11"W x 12"H	
- GR Version	16"L x 11"W x 12"H	
Diaphragm Material	GREENTECH (Std) Buna-N (Opt)	

Lubrication: Requires 39 oz. of Udor Lube 40W Premium Pump Oil. Alternate Oil: 30W non-detergent or 15W-40 non-detergent oil.

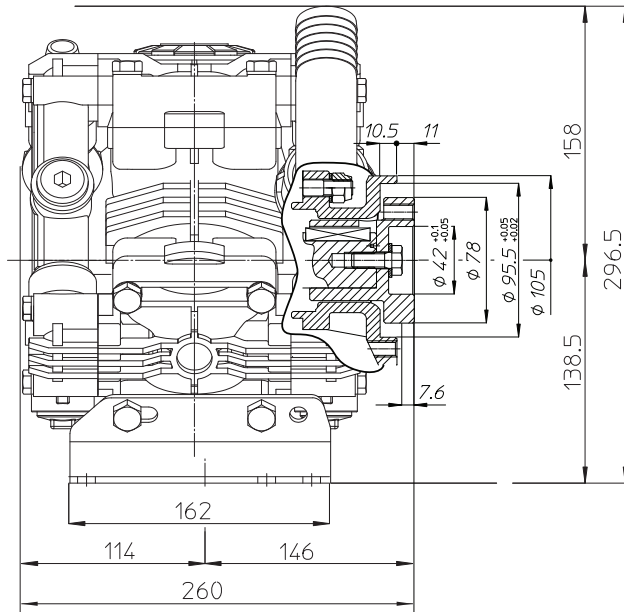

VA Universal Drive Face Detail

Dimensional Drawings are Shown in Millimeters. To Convert to Inches, Multiply Dimension x 0.03937

TORQUE SPECS

Ref.	Description	Ft./lb.	Nm
1	Diaphragm Bolts (Use Loctite 243)	18	25
2	Head Bolts	30	40
3	Pulsation Dampener Bolts	18	25
4	Oil Cup Bolts	6	8
5	Manifold Bolts (Plastic)	14	20

