

## 3-Cylinder, Low-Pressure Diaphragm Pumps

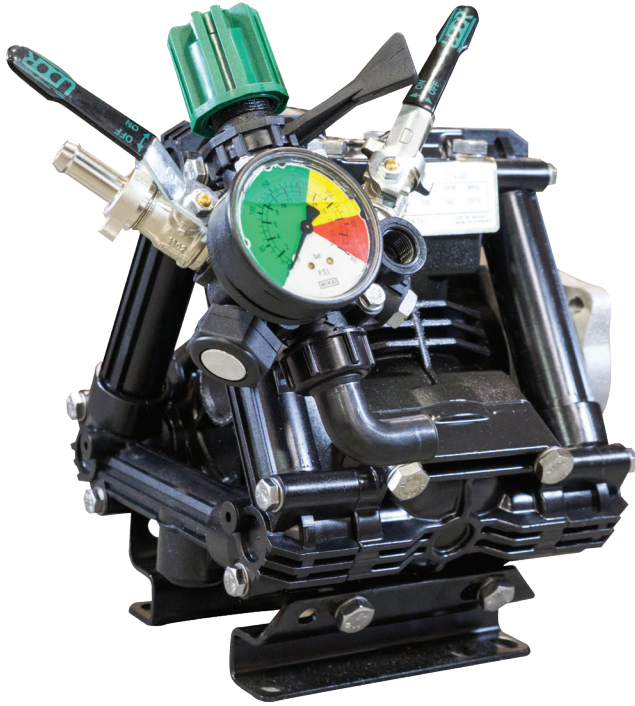

ZETA 40 low pressure 3-cylinder diaphragm pumps have anodized aluminum bodies with plasticized aluminum heads, stainless steel valves and glass-filled nylon manifolds. A control valve with pressure gauge is standard on all models.

ZETA pumps are excellent for various horticultural and agricultural spraying applications.

Pumps are available with Universal VA Drive Face or gear reductions for 4 to 6.5 HP gas engines.

Model	GPM	l/min	PSI	bar	RPM	Drive Configuration	Weight
ZETA 40 VA	10.5	44	300	20	550	Universal VA Drive Face.	29 LBS
ZETA 40 VAGR3/4	10.5	44	300	20	550	Gear Reduction for 3/4" Shaft Gas Engine, 4-6.5 HP	36 LBS

Specifications	ZETA 40	Description	Part #
Inlet Port	1-1/4" Hose Barb	Diaphragm Kit - GREENTECH	6062.97
Outlet Ports - Valve	(2) 1/2" Hose Barb	Diaphragm Bolt & Washer Kit	6062.48
Bypass	3/4" Hose Barb	Valve Kit	6062.D8
Piston Diameter	55.0mm	Regulator Repair Kit	6062.A9
Crankshaft Stroke/Code	11.0mm / J	Complete Repair Kit	8700.60CK
Dims. - Pump Only	11"L x 11"W x 12"H		
- GR Version	16"L x 11"W x 12"H		

**Lubrication:** Requires 39 oz. of Udor Lube 40W Premium Pump Oil.  
Alternate Oil: 30W non-detergent or 15W-40 non-detergent oil.



# ZETA 40 VAGR3/4

Maximum Flow	10.5 GPM / 44 lpm
Maximum Pressure	300 PSI / 20 bar
Maximum RPM	550 RPM
Inlet Port - Hose Barb	1-1/4" HB
Outlet Ports - Hose Barb, Valve	(2) 1/2" HB
Bypass - Hose Barb	3/4" HB
Dimensions - ZETA 40E GR	16"L x 11"W x 12"H
Weight - ZETA 40E GR	36 lbs

**Lubrication:** Requires 39 oz. of Udor Lube 40W Premium Pump Oil.  
Alternate Oil: 30W non-detergent or 15W-40 non-detergent oil.

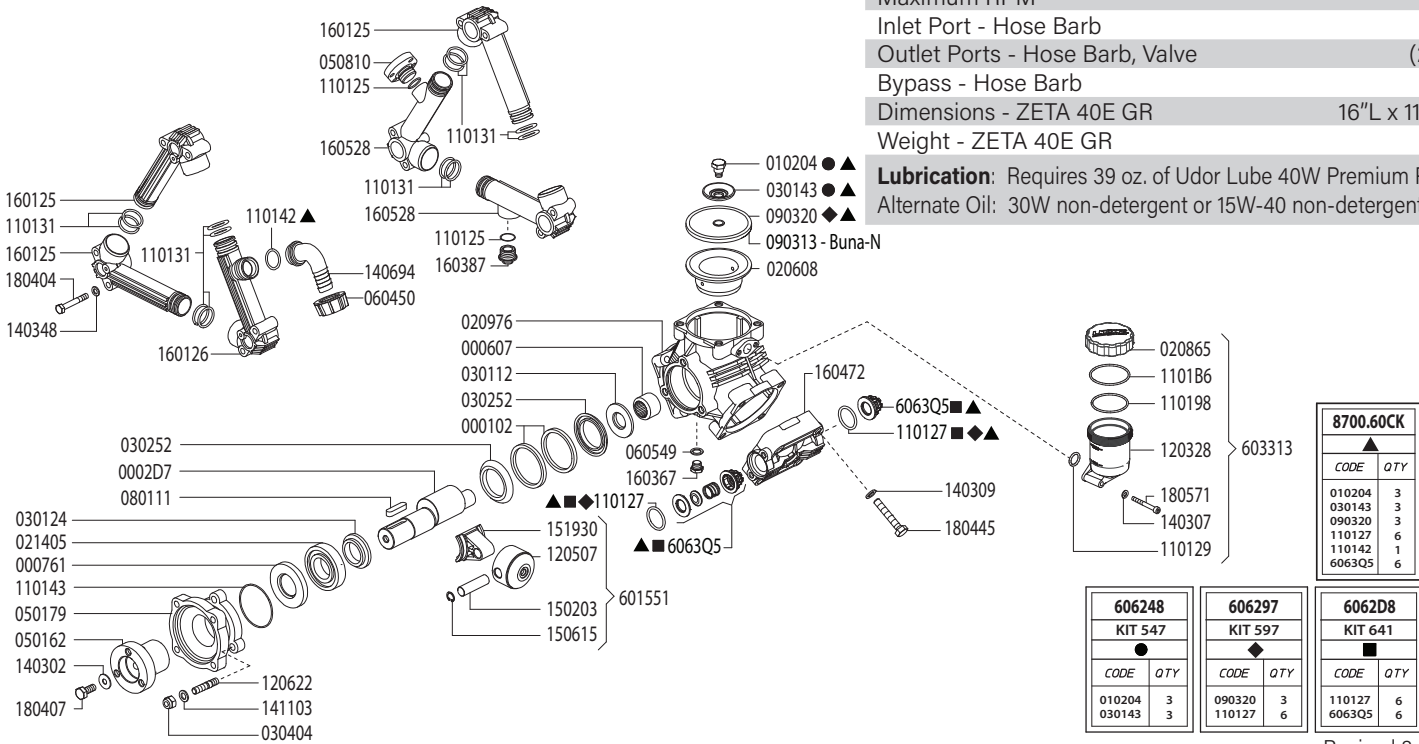

8700.60CK	
CODE	QTY
010204	3
030143	3
090320	3
110127	6
110142	1
6063Q5	6

606248 KIT 547	
CODE	QTY
010204	3
030143	3

606297 KIT 597	
CODE	QTY
090320	3
110127	6

6062D8 KIT 641	
CODE	QTY
110127	6
6063Q5	6

Revised 8-29-2024

Part #	Description	Qty
0001.02	RETAINER RING	2
0002.D7	CRANKSHAFT	1
0006.07	BEARING D25	1
0007.61	OIL SEAL D35	1
0102.04	DIAPHRAGM BOLT ●▲	3
0206.08	PISTON SLEEVE D55	3
0208.65	OIL RESERVIOR CAP	1
0209.76	CRANKCASE	1
0214.05	BALL BEARING D35	1
0301.12	BEARING DISC D25	1
0301.24	BEARING DISC D35	1
0301.43	DIAPHRAGM WASHER ●▲	3
0302.52	ROD SPACER	2
0304.04	NY-LOCK NUT M10	3
0501.62	ADAPTER - VA	1
0501.79	FLANGE - VA	1
0508.10	REGULATOR MOUNTING ADAPTER	1
0604.50	BARB NUT G1-1/2"	1
0605.49	OIL PLUG GASKET	1
0801.11	KEY 10X8X40	1
0903.13	PISTON DIAPHRAGM 100mm,BUNA-N	3
0903.20	PISTON DIAPHRAGM 100mm,GREENTECH ◆▲	3
1101.25	O-RING - PLUG & ADAPTER	2
1101.27	O-RING - VALVE ◆■▲	6
1101.29	O-RING - OIL RESERVIOR	1
1101.31	O-RING - MANIFOLD	12
1101.42	O-RING - INLET BARB▲	1
1101.43	O-RING - FLANGE	1
1101.98	O-RING - OIL RESERVIOR	1
1101.B6	O-RING - OIL RESERVIOR	1
1203.28	OIL RESERVIOR	1
1205.07	ALUMINUM PISTON D55	3

Part #	Description	Qty
1206.22	STUD M10X46	3
1403.02	WASHER M10	3
1403.07	WASHER M8	2
1403.09	WASHER M10	12
1403.48	WASHER M8	12
1406.94	SUCTION HOSE BARB 1-1/4"	1
1411.03	SERATED WASHER M10	3
1502.03	CONNECTING ROD PIN 15X48	3
1506.15	SNAP RING D15	3
1519.30	CONNECTING ROD	3
1601.25	INLET/OUTLET MANIFOLD TUBE	3
1601.26	SUCTION MANIFOLD TUBE G1-1/2" M	1
1603.67	OIL PLUG G1/4"	1
1603.87	MANIFOLD PLUG G3/4"	2
1604.72	HEAD	3
1605.28	DISCHARGE MANIFOLD TUBE G3/4" F	2
1804.04	HEX BOLT M8X55	12
1804.07	HEX BOLT M10X25	1
1804.45	HEX BOLT M10X60	12
1805.71	ALLEN BOLT M6X50	2
6015.51	PISTON / ROD ASSEMBLY D55	3
6033.13	OIL RESERVIOR ASSEMBLY	1
6063.Q5	VALVE ASSEMBLY W/O O-RING ■▲	6
6062.48	DIAPHRAGM WASHER/BOLT (KIT 547)	1
6062.97	DIAPHRAGM KIT - GREENTECH (KIT 597)	1
6062.D8	INLET/OUTLET VALVE KIT (KIT 641)	1
8700.60CK	COMPLETE REPAIR KIT	1

- Parts in 6062.48 (Kit 547)
- ◆ Parts in 6062.97 (Kit 597).
- Parts in 6062.D8 (Kit 641).
- ▲ Parts in 8700.60CK

**GAS ENGINE GEAR REDUCTION FOR  
KAPPA-55, ZETA-40/85/120 DIAPHRAGM PUMPS  
on GAS ENGINES with 3/4" SHAFTS  
REQUIRES 16 OZ. 90W GEAR LUBE**

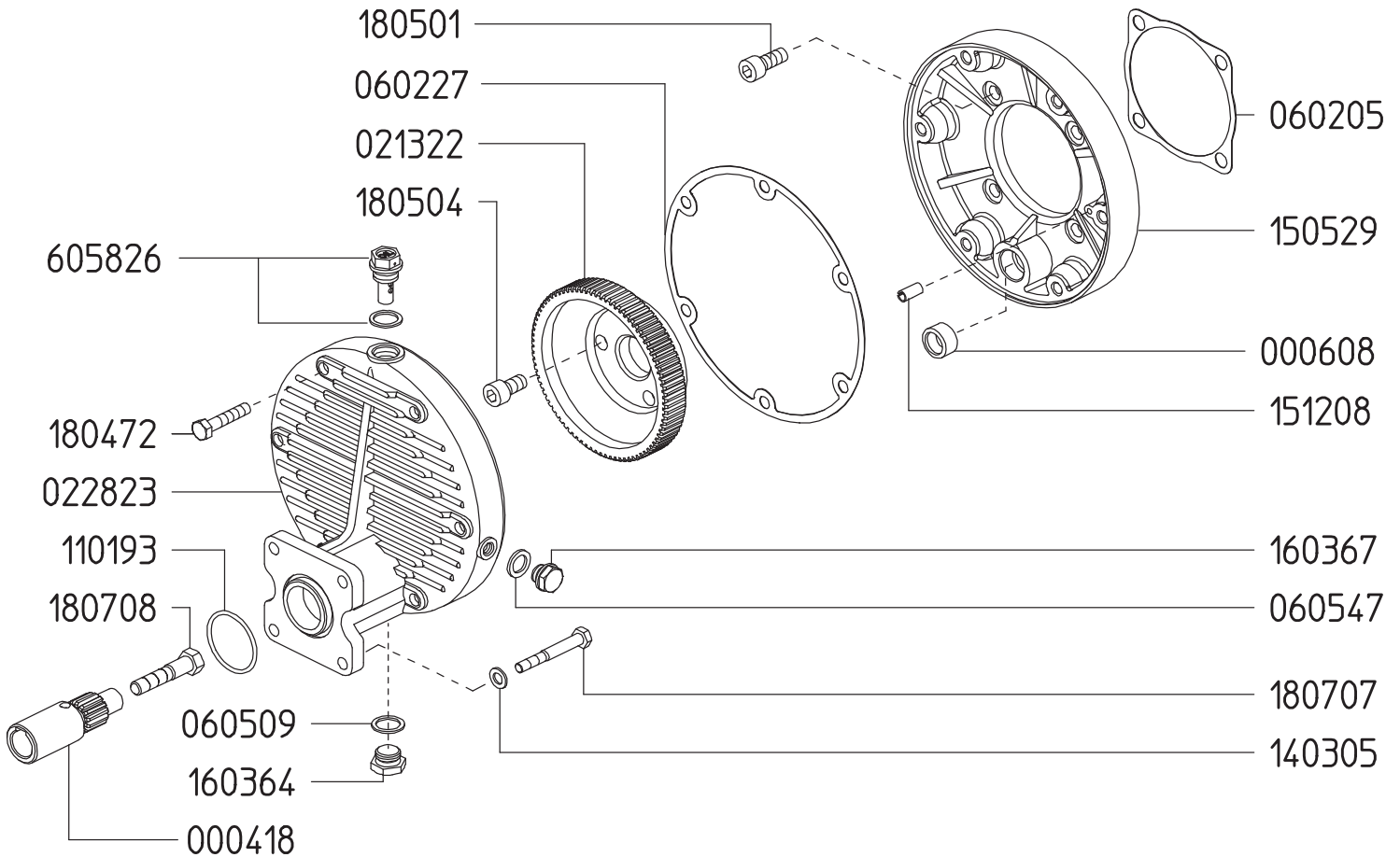

Revised 8-29-2024

Part #	Description	Qty	Part #	Description	Qty
0004.18	GEAR SHAFT - 3/4"	1	1505.29	GEAR CASE - PUMP	1
0006.08	BEARING	1	1512.08	ALIGNMENT PIN	1
0213.22	PUMP GEAR - VA	1	1603.64	OIL PLUG G3/8	1
0228.23	GEAR CASE - ENGINE	1	1603.67	OIL PLUG G1/4	1
0602.05	GASKET	1	1804.72	HEX BOLT M8X50	6
0602.27	GASKET	1	1805.01	ALLEN BOLT M10X25	4
0605.09	GASKET - ALUMINUM	1	1805.04	ALLEN BOLT M10X20	3
0605.47	GASKET - ALUMINUM	1	1807.07	HEX BOLT 5/16 X 1"	4
1101.93	O-RING	1	1807.08	HEX BOLT 5/16 X 2-1/4"	1
1403.05	WASHER	4	6058.26	VENTED OIL CAP	1

## Adjustable Pressure Regulator

Maximum Flow	27.0 GPM / 102 lpm
Maximum Pressure	350 PSI / 24 bar
Inlet Port - Hose Barb	-
Outlet Ports - Hose Barb, Valve	(2) 1/2" HB
Bypass - Hose Barb	3/4" HB

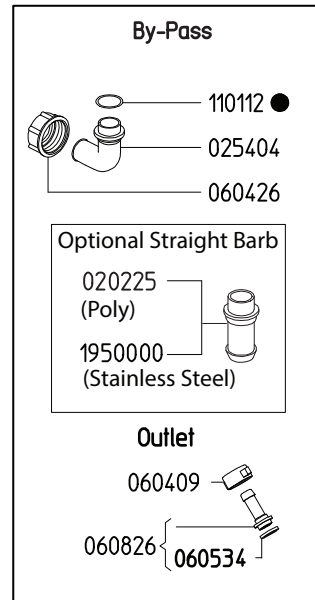
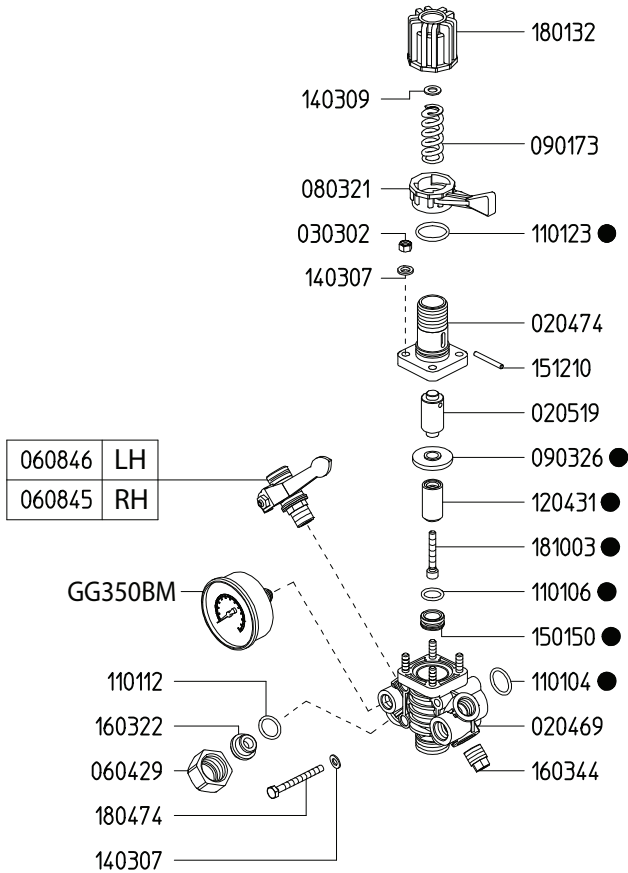

6062A9	
KIT 608	
CODE	QTY
090326	1
110104	1
110106	1
110112	1
110123	1
120431	1
150150	1
181003	1

Revised 8-29-2024

Part #	Description	Qty
0202.25	BYPASS HOSE BARB - STRAIGHT (OPTIONAL)	1
0204.69	BODY	1
0204.70	BODY	1
0205.19	CYLINDER	1
0254.04	BYPASS HOSE BARB - ELBOW	1
0303.02	NUT	4
0604.09	BARB NUT	2
0604.26	BYPASS BARB NUT	1
0604.29	NUT	1
0605.34	GASKET	2
0608.26	1/2" HOSE BARB W/GASKET	2
0608.45	BALL VALVE - RIGHT	1
0608.46	BALL VALVE - LEFT	1
0803.21	LEVER	1
0901.73	SPRING (LP 300 PSI)	1
0903.26	DIAPHRAGM ●	1
1101.04	O-RING ●	1
1101.06	O-RING ●	1

Part #	Description	Qty
1101.12	O-RING ●	2
1101.23	O-RING ●	1
1204.31	POPPET ●	1
1403.07	WASHER	6
1501.50	SEAT ●	1
1512.10	PIN	1
1603.22	PLUG	1
1603.44	PLUG	1
1801.32	ADJUSTMENT KNOB	1
1804.74	BOLT	2
1810.03	STAINLESS STEEL BOLT ●	1
19500.00	BYPASS HOSE BARB - STRAIGHT, SS (OPTIONAL)	1
6062.A9	REPAIR KIT FOR 6010.9X CONTROL UNIT (KIT 608)	1
GG350BM	PRESSURE GAUGE - 350 PSI BACK MOUNT	1

● Parts Included in Repair Kit #6062.A9 (KIT 608)

The control unit features a manual dump valve, pressure control knob, glycerine filled pressure gauge, and two ball valve discharge ports.

1. Before operating or re-operating the pump move lever (0803.21) to the dump position (Right) so the pump will start at zero pressure. (Failure to do so will void the pump warranty.)
2. Turn pressure adjustment knob (1801.32) counter clockwise to relieve spring tension. This step only applies to the initial start up and is not necessary in daily operation of pump.
3. Start unit and let run until air is evacuated from the system.
4. Move lever (0803.21) to the pressure position (Left) open spray gun or spray boom and turn the pressure adjustment knob (1801.32) clockwise until desired operating pressure is achieved.

# ZETA 40/85 DIMENSIONS

All Dimensions are WITHOUT Control Unit or Regulator

Dimensional Drawings are Shown in Millimeters. To Convert to Inches, Multiply Dimension x 0.03937

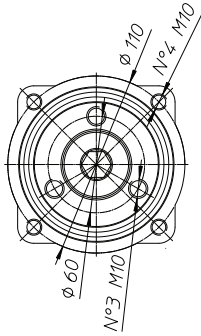
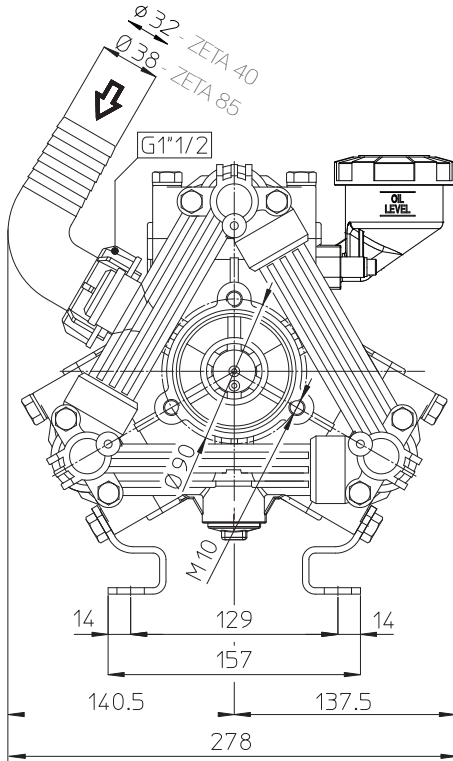

Specifications	ZETA 40	ZETA 85
Inlet Port - Hose Barb	1" HB	1-1/2" HB
Outlet Ports - Hose Barb, Valve	(2) 1/2" HB	(2) 1/2" HB
Bypass - Hose Barb	3/4" HB	3/4" HB
Dimensions - Pump Only		11"L x 11"W x 12"H
- GR Version		16"L x 11"W x 12"H
Diaphragm Material	GREENTECH (Std) Buna-N (Opt)	

**Lubrication:** Requires 39 oz. of Udor Lube 40W Premium Pump Oil. Alternate Oil: 30W non-detergent or 15W-40 non-detergent oil.

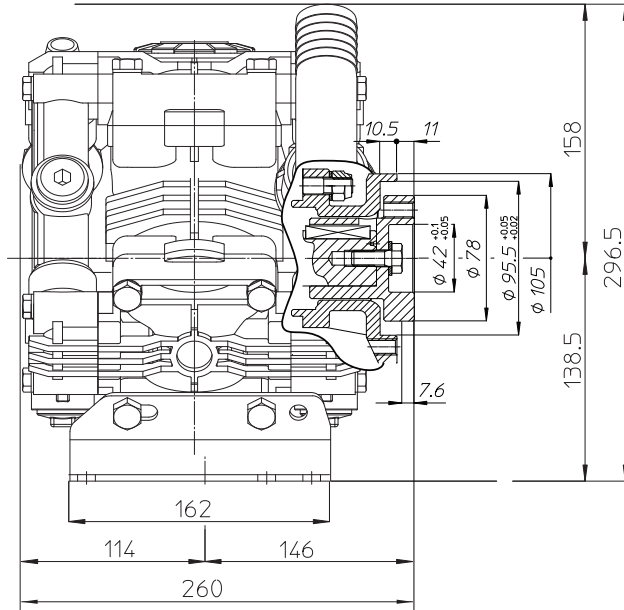

## VA Universal Drive Face Detail

Dimensional Drawings are Shown in Millimeters. To Convert to Inches, Multiply Dimension x 0.03937

## TORQUE SPECS

Ref.	Description	Ft./lb.	Nm
1	Diaphragm Bolts (Use Loctite 243)	18	25
2	Head Bolts	30	40
3	Pulsation Dampener Bolts	18	25
4	Oil Cup Bolts	6	8
5	Manifold Bolts (Plastic)	14	20

