

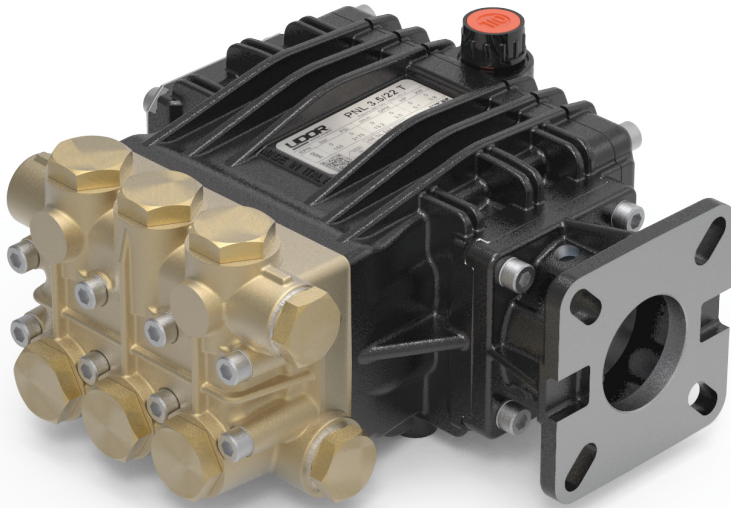

# PNL SERIES

## Direct Drive, Gas Engine Flange Models

3/4" Hollow Shaft, SAE J609-A Flange and Set Screw  
3400 RPM



- Brass Manifold
- Heat Treated Crankshaft
- Stainless Steel Piston Guides
- High Strength Aluminum Alloy or Bronze Connecting Rods
- Industrial Quality Ball Bearings and Needle Bearings
- Solid Ceramic Plungers
- Stainless Steel Check Valves
- Heavy Duty Flat Base High Pressure Seals
- Dual Oil Sight Gauges
- 10.25 oz. Capacity Vented Oil Bath Crank Case
- 3/8" BSP-F Inlet. 3/8" BSP-F Outlet
- Max Fluid Temp, 160°F

### PNL Series Direct Drive, Gas Engine Flange Plunger Pumps

PNL Series standard duty plunger pumps include a range of models with flow rates from 3.0 to 3.5 GPM and pressures up to 2465 PSI.

Other drive options include 24mm solid shaft, electric motor flange, gas engine gear reduction and hydraulic motor flange.

Applications include general pressure cleaning, sewer jetting, vehicle wash equipment and fire fighting applications.

	Model	Flow		Pressure		Plunger Dia.	Crankshaft		Power	Seal Kit	Valve Kit	Wt.
		GPM	l/min	PSI	bar		Stroke	Code				
3400 RPM	PNL 2.5/20 T	2.5	9.5	2030	140	15mm	6.5mm	F	4.0 HP Gas	6061.07	6061.01	13 lbs
	PNL 3.0/20 T	3.0	11.4	2030	140	15mm	7.5mm	H	5.5 HP Gas	6061.07	6061.01	13 lbs
	PNL 3.0/25 T	3.0	11.4	2465	170	15mm	7.5mm	H	6.5 HP Gas	6061.07	6061.01	14 lbs
	PNL 3.5/22 T	3.5	13.2	2175	150	15mm	9.0mm	M	6.5 HP Gas	6061.07	6061.01	14 lbs

NOTE: All pump models available with left-hand drive option. Add 'L' to model number when ordering (ex. PNL 3.0/20 TL)



6180 140th Avenue NW  
Ramsey, MN 55303

Ph: 651-785-0666  
Fax: 800-732-2670

www.udorusa.com  
www.boominator.com  
info@udorusa.com



Scan this QR Code  
for More Information

PNL-T  
2024B

MAX FLOW  
MAX PRESSURE  
RATED PUMP SPEED  
POWER REQUIREMENT  
LUBRICATION

3.0 GPM / 11.4 L/MIN  
2030 PSI / 140 BAR  
3400 RPM  
5.5 HP GAS ENGINE  
10.25 OZ UDOR LUBE

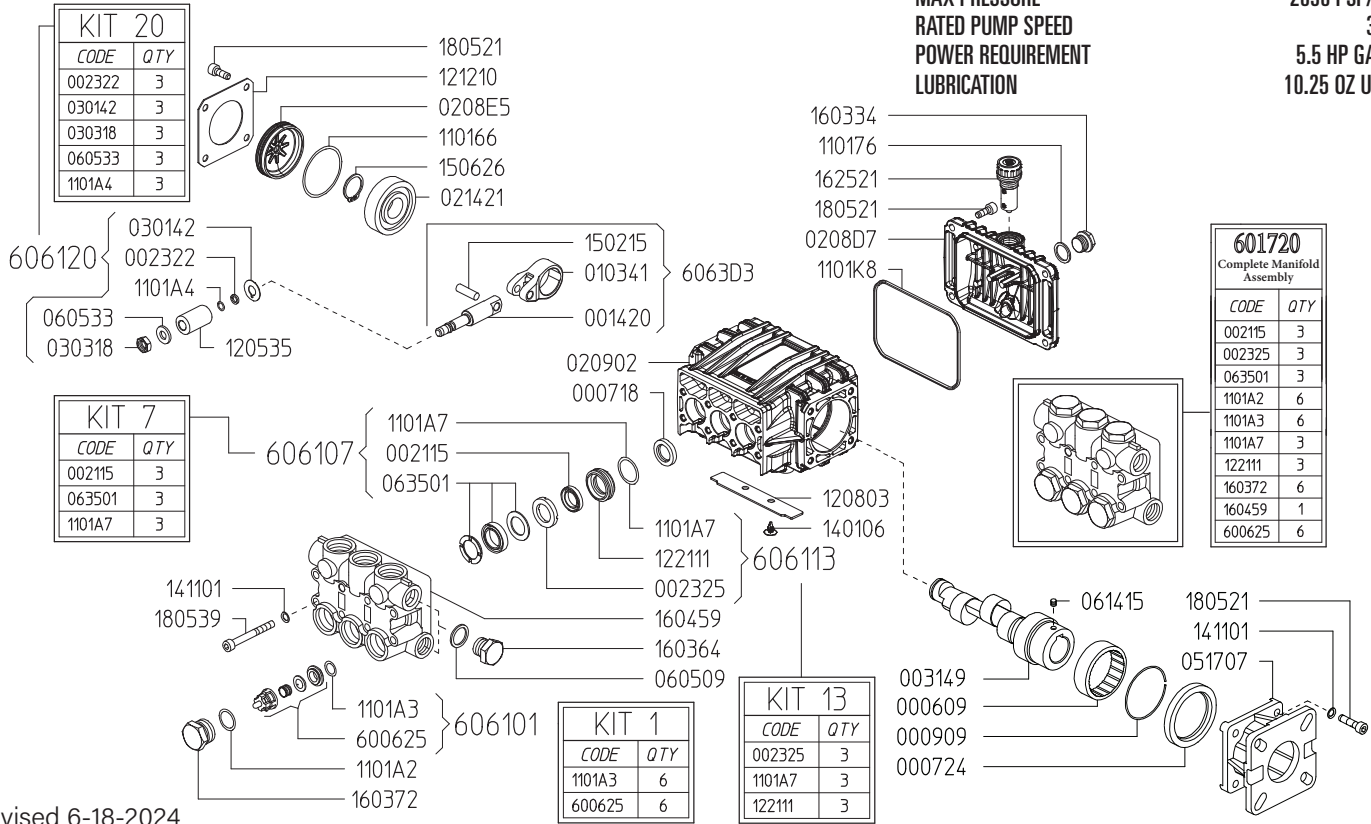

Revised 6-18-2024

Part #	Description	Qty	Part #	Description	Qty
0006.09	BUSHING D45X52X16 HK45-16	1	1101.A7	O-RING - LP SEAL RETAINER <sup>BCE</sup>	3
0007.18	OIL SEAL D15X24X4	3	1101.K8	O-RING - BACK COVER	1
0007.24	OIL SEAL D40X52X7	1	1205.35	CERAMIC PLUNGER D15X30 "PN"	3
0009.09	ELASTIC RING D52X2.5	1	1208.03	COVER	1
0014.20	PLUNGER GUIDE D15/18 "PN"	3	1212.10	METAL COVER "PN"	1
0021.15	WATER SEAL LP. D15 <sup>B</sup>	3	1221.11	LOW PRESS. SEAL RETAINER D15 <sup>CE</sup>	3
0023.22	RING D6.3X9X1.3 2021 "PN/C/G" <sup>CE</sup>	3	1401.06	RIVER M4X10	
0023.25	INTERMEDIATE RING D15 "PN"	3	1411.01	SERATED WASHER D6	12
0031.49	HOLLOW SHAFT "PN" D3/4"	1	1502.15	PIN D7X25.5	3
0103.41	CONNECTING ROD "PN/PS"	3	1506.26	SNAP RING D20	1
0208.D7	BACK COVER "PN"	1	1603.34	PLUG G1/4	1
0208.E5	COVER "PN"	1	1603.64	PLUG G3/8	1
0209.02	CRANKCASE "PN/PS"	1	1603.72	VALVE PLUG "PN"PISTON D15/18 <sup>E</sup>	6
0214.21	BALL BEARING D20X52X15	1	1604.59	HEAD "PN" PISTON D15/18 <sup>E</sup>	1
0301.42	SLINGER RING "PN/PK/PKWT/PS" <sup>D</sup>	3	1625.21	OIL PLUG G3/8 "PN"	1
0303.18	NUT "PN/PK/PKWT/PS M8XH5 <sup>D</sup>	3	1805.21	ALLEN BOLT M6X22	8
0517.07	ENGINE FLANGE "PN" HP2/5	1	1805.39	ALLEN BOLT M6X60	8
0605.09	GASKET D17X23X1.5 (G3/8)	1	6006.25	VALVE ASSY "PN" W/O O-RING <sup>AE</sup>	6
0605.33	GASKET D8X14X2 <sup>D</sup>	3	6017.20	COMPLETE MANIFOLD ASSEMBLY	1
0614.15	SET SCREW M8X8	1	6061.01	KIT 1 - VALVE KIT "PN/PW"	1
0635.01	HIGH PRESS. SEAL ASSY D15 <sup>B</sup>	3	6061.07	KIT 7 - WATER SEAL KIT D15 "PN/PK"	1
1101.66	O-RING - BEARING COVER	1	6061.13	KIT 13 - BRASS RING KIT D15 "PN"	1
1101.76	O-RING - OIL PLUG	1	6061.20	Kit 20 - PLUNGER KIT D15/18 "PN"	1
1101.A2	O-RING - VALVE CAP <sup>E</sup>	6			
1101.A3	O-RING - VALVE <sup>AE</sup>	6			
1101.A4	O-RING - PLUNGER <sup>D</sup>	3			

<sup>A</sup> Parts in 6061.01 (Kit 1).

<sup>B</sup> Parts in 6061.07 (Kit 7).

<sup>C</sup> Parts in 6061.13 (Kit 13).

<sup>D</sup> Parts in 6061.20 (Kit 20).

<sup>E</sup> Parts in 6017.20 (Complete Manifold Assembly).

*Dimensional Drawings are  
Shown in Millimeters.  
To Convert to Inches,  
Multiply Dimension x 0.03937*

## PN SERIES PUMPS - 3/4" HOLLOW SHAFT w/ GAS ENGINE FLANGE

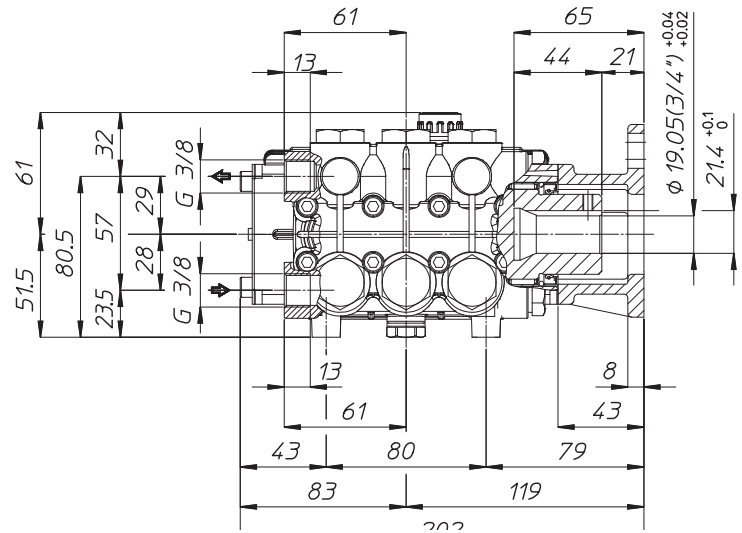
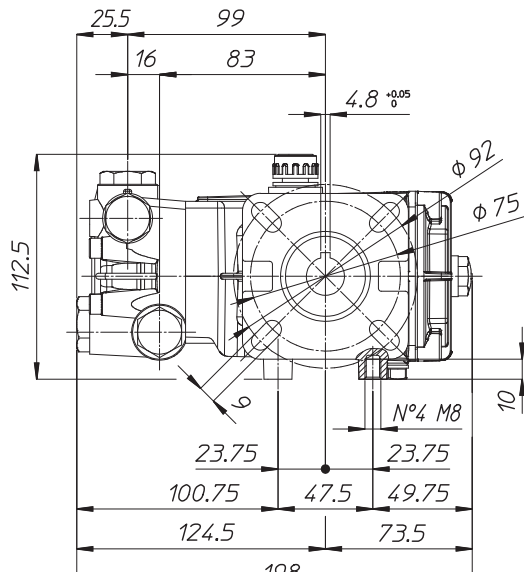

## TORQUE SPECS

Ref.	Description	Ft./lb.	Nm	Loctite®
1	Head Bolts	8	11	-
2	Valve Caps	75	100	243
3	Inlet Cap	60	80	-
4	Outlet Cap	60	80	243
5	Bearing Flange Bolts	8	11	-
6	Rear Cover Bolts	8	11	-
7	Connecting Rod Bolts	-	-	-
8	Plunger Bolts	11	15	270
9	Valve Cover Bolts	-	-	-
10	Oil Drain Plug	6	8	-

