

## Gear Reduction, Gas Engine Models

3/4" Hollow Shaft. SAE J609-A Flange. 2.2:1 Gear Reduction  
Gas Engine Gear Reduction

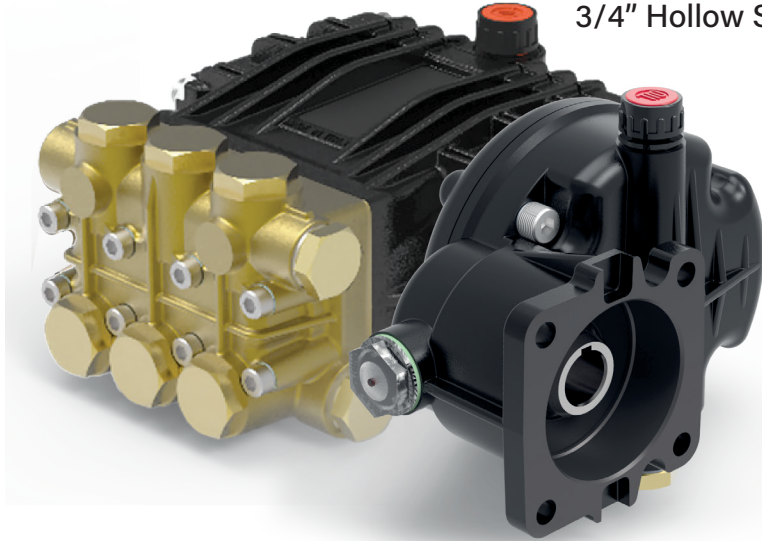

- Brass Manifold
- Heat Treated Crankshaft
- Stainless Steel Piston Guides
- High Strength Aluminum Alloy or Bronze Connecting Rods
- Industrial Quality Ball Bearings and Needle Bearings
- Solid Ceramic Plungers
- Stainless Steel Check Valves
- Heavy Duty Flat Base High Pressure Seals
- Dual Oil Sight Gauges
- 10.25 oz. Capacity Vented Oil Bath Crank Case
- 3/8" BSP-F Inlet. 3/8" BSP-F Outlet
- Max Fluid Temp, 160°F

### PNC Series Gas Engine Gear Reduction Plunger Pumps

PNC Series standard duty plunger pumps include a wide range of models with flow rates from 2.9 to 3.4 GPM and pressures up to 2465 PSI.

Other drive options include 24mm solid shaft, electric motor flange, gas engine flange and hydraulic motor flange.

Applications include general pressure cleaning, sewer jetting, vehicle wash equipment and fire fighting applications.

	Model	Flow		Pressure		Plunger Dia.	Crankshaft		Power	Seal Kit	Valve Kit	Wt.
		GPM	l/min	PSI	bar		Stroke	Code				
Gear Reduction	PNC 11/17 GR	2.9	11	2465	170	18mm	10.5mm	O	6.5 HP Gas	6061.08	6061.01	18 lbs
	PNC 13/15 GR	3.4	13	2175	150	18mm	12.5mm	S	6.5 HP Gas	6061.08	6061.01	18 lbs



MAX FLOW  
MAX PRESSURE  
RATED PUMP SPEED  
POWER REQUIREMENT  
LUBRICATION

2.9 GPM / 11.0 L/MIN  
2465 PSI / 170 BAR  
1450 RPM  
6.5 HP GAS  
10.25 OZ UDOR LUBE

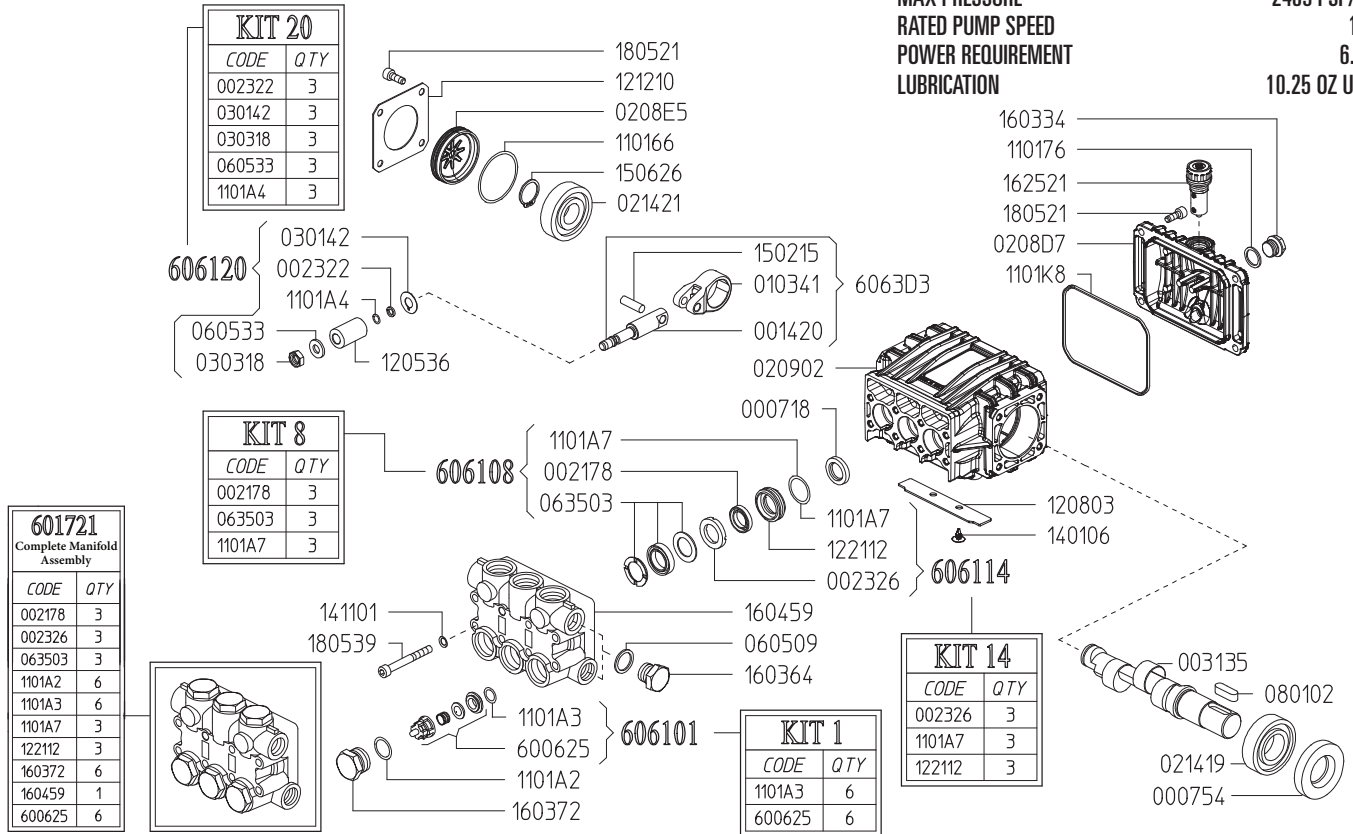

Revised 6-18-2024

Part #	Description	Qty	Part #	Description	Qty
000718	OIL SEAL D15X24X5	3	1205.36	CERAMIC PLUNGER D18X30 "PN"	3
000754	OIL SEAL D25X52X10	1	1208.03	COVER - PN 2024	
0014.20	PLUNGER GUIDE D15/18 "PN"	3	1212.10	METAL COVER "PN"	1
0021.78	LOW PRESSURE WATER SEAL D15 <sup>B E</sup>	3	1221.12	LOW PRESS. SEAL RETAINER D18 <sup>C E</sup>	3
0023.22	RING D6.3X9X1.3 2021 "PN/C/G" <sup>D</sup>	3	1401.06	RIVET D4X10	2
0023.26	INTERMEDIATE RING D18 "PN" <sup>C E</sup>	3	1411.01	SERATED WASHER D6	8
0031.35	MALE SHAFT "PN" D24	1	1502.15	PIN D7X25.5	3
0103.41	CONNECTING ROD "PN/PS"	3	1506.26	SNAP RING D20	1
0208.D7	BACK COVER "PN"	1	1603.34	PLUG G1/4	1
0208.E5	COVER "PN"	1	1603.64	PLUG G3/8	1
0209.02	CRANKCASE "PN/PS"	1	1603.69	OIL PLUG G1/4+GASKET	1
0214.19	BALL BEARING D25X52X15	1	1603.72	VALVE PLUG "PN" PISTON D15/18 <sup>E</sup>	6
0214.21	BALL BEARING D20X52X15	1	1604.59	HEAD "PN" PISTON D15/18 <sup>E</sup>	1
0301.42	SLINGER RING "PN/PK/PKWT/PS" <sup>D</sup>	3	1625.21	OIL PLUG G3/8 "PN"	1
0303.18	NUT "PN/PK/PKWT/PS M8XH5" <sup>D</sup>	3	1805.21	ALLEN BOLT M6X22	8
0605.09	GASKET D17X23X1.5 (G3/8)	1	1805.39	ALLEN BOLT M6X60	8
0605.33	GASKET D8X14X2 <sup>D</sup>	3	6006.25	VALVE ASSY "PN" W/O O-RING <sup>A E</sup>	6
0635.03	HIGH PRESS. SEAL ASSY D18 <sup>B E</sup>	3	6017.21	COMPLETE MANIFOLD ASSEMBLY	1
0801.02	KEY A8X7X25	1	6061.01	KIT 1 - VALVE KIT "PN/PW"	1
1101.76	O-RING - OIL PLUG	1	6061.08	KIT 8 - WATER SEAL KIT D18 "PN"	1
1101.66	O-RING - BEARING COVER	1	6061.14	KIT 14 - BRASS RING KIT D18 "PN"	1
1101.A2	O-RING - VALVE CAP <sup>E</sup>	6	6061.20	KIT 20 - PLUNGER KIT D15/18 "PN"	1
1101.A3	O-RING - VALVE <sup>A E</sup>	6			
1101.A4	O-RING - PLUNGER <sup>D</sup>	3			
1101.A7	O-RING - LP SEAL RETAINER <sup>B C E</sup>	3			
1101.K8	O-RING - BACK COVER	1			

<sup>A</sup> Parts in 6061.01 (Kit 1)  
<sup>B</sup> Parts in 6061.04 (Kit 8)  
<sup>C</sup> Parts in 6061.14 (Kit 14)  
<sup>D</sup> Parts in 6061.20 (Kit 20)  
<sup>E</sup> Parts in 6017.21 (Complete Manifold Assembly)

**GAS ENGINE GEAR REDUCTION FOR  
P-SERIES PLUNGER PUMPS  
on GAS ENGINES with 3/4" SHAFTS**  
REQUIRES 6 OZ. 90W GEAR LUBE

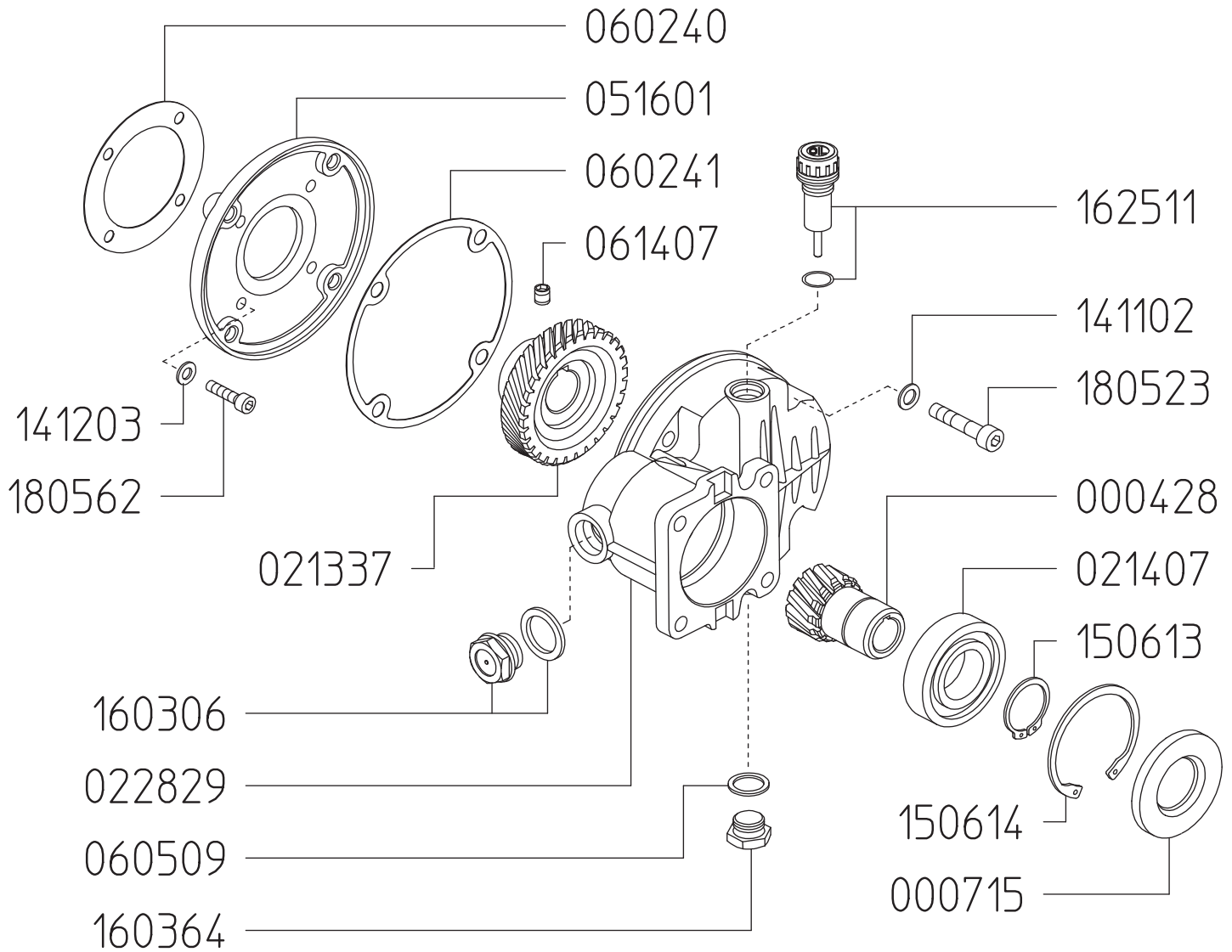

Part #	Description	Qty	Part #	Description	Qty
0004.28	GEAR SHAFT "RP123" D19.05	1	1411.02	SERATED WASHER D8	4
0007.15	OIL SEAL D30	1	1412.03	SERATED WASHER D10	4
0213.37	GEAR "RP123" D24	1	1506.13	SNAP RING D30	1
0214.07	BALL BEARING D30	1	1506.14	SNAP RING D62	1
0228.29	COUPLER "RP123"	1	1603.06	OIL PLUG G1/2 + GASKET	1
0516.01	FLANGE "RP123"	1	1603.64	PLUG G3/8	1
0602.40	GASKET "RP123"	1	1625.11	OIL PLUG G3/8 "PN"	1
0602.41	GASKET "RP123"	1	1805.23	ALLEN BOLT M8X40	4
0605.09	GASKET D17	1	1805.62	ALLEN BOLT M6X20	4
0614.07	SET SCREW M8X10 UNI5923	1			

*Dimensional Drawings are  
Shown in Millimeters.  
To Convert to Inches,  
Multiply Dimension x 0.03937*

## PN SERIES PUMPS - 24MM SOLID SHAFT

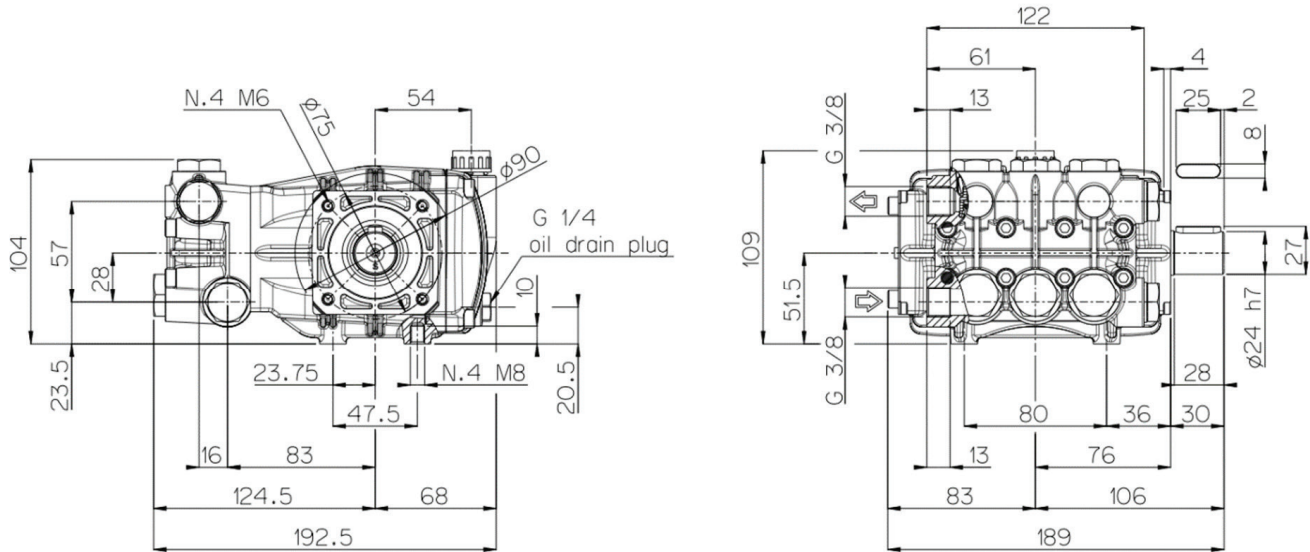

## TORQUE SPECS

Ref.	Description	Ft./lb.	Nm	Loctite®
1	Head Bolts	8	11	-
2	Valve Caps	75	100	243
3	Inlet Cap	60	80	-
4	Outlet Cap	60	80	243
5	Bearing Flange Bolts	8	11	-
6	Rear Cover Bolts	8	11	-
7	Connecting Rod Bolts	-	-	-
8	Plunger Bolts	11	15	270
9	Valve Cover Bolts	-	-	-
10	Oil Drain Plug	6	8	-

