



GAMMA 62 GR SERIES

Gas Engine, Gear Reduction Drive

1" Hollow Shaft.
6.4:1 Gear Reduction



- Anodized Aluminum Crankcase
- Solid Ceramic Plungers
- Stainless Steel Check Valves
- High Strength Aluminum Connecting Rods
- 1-1/4" Hose Barb Inlet. (2) 3/4" BSP-F Outlet
- 57.6 oz. Capacity Vented Oil Bath Crank Case
- Max Fluid Temp, 160°F

GAMMA 62 Series Gas Engine, Gear Reduction Drive Plunger Pumps

GAMMA 62 Series industrial duty plunger pumps are rated at 17.7 GPM and pressures up to 725 PSI.

Pumps are available with two gear reduction options: up to 16 HP or 18+ HP, with 1" shaft sizes

Applications include fire fighting,, construction, de-icing and orchard spraying.

	Model	Flow		Pressure		Plunger Dia.	Crankshaft		Power	Seal Kit	Valve Kit	Wt.
		GPM	l/min	PSI	bar		Stroke	Code				
Gear	GAMMA 62/GR	17.7	67.0	725	50	40mm	30.0mm	F	9-13 HP Gas	6062.A1	6062.65	64 lbs
Reduction	GAMMA 62/GR-18	17.7	67.0	725	50	40mm	30.0mm	F	16-20 HP Gas	6062.A1	6062.65	70 lbs



6180 140th Avenue NW
Ramsey, MN 55303

Ph: 651-785-0666
Fax: 800-732-2670

www.udorusa.com
www.boominator.com
info@udorusa.com



Scan this QR Code
for More Information

**G62GR
2024A**

MAX FLOW
MAX PRESSURE
RATED PUMP SPEED
POWER REQUIREMENT
LUBRICATION

17.7 GPM / 67.0 L/MIN
725 PSI / 50 BAR
600 RPM
9-13 HP GAS
57.6 OZ UDOR LUBE

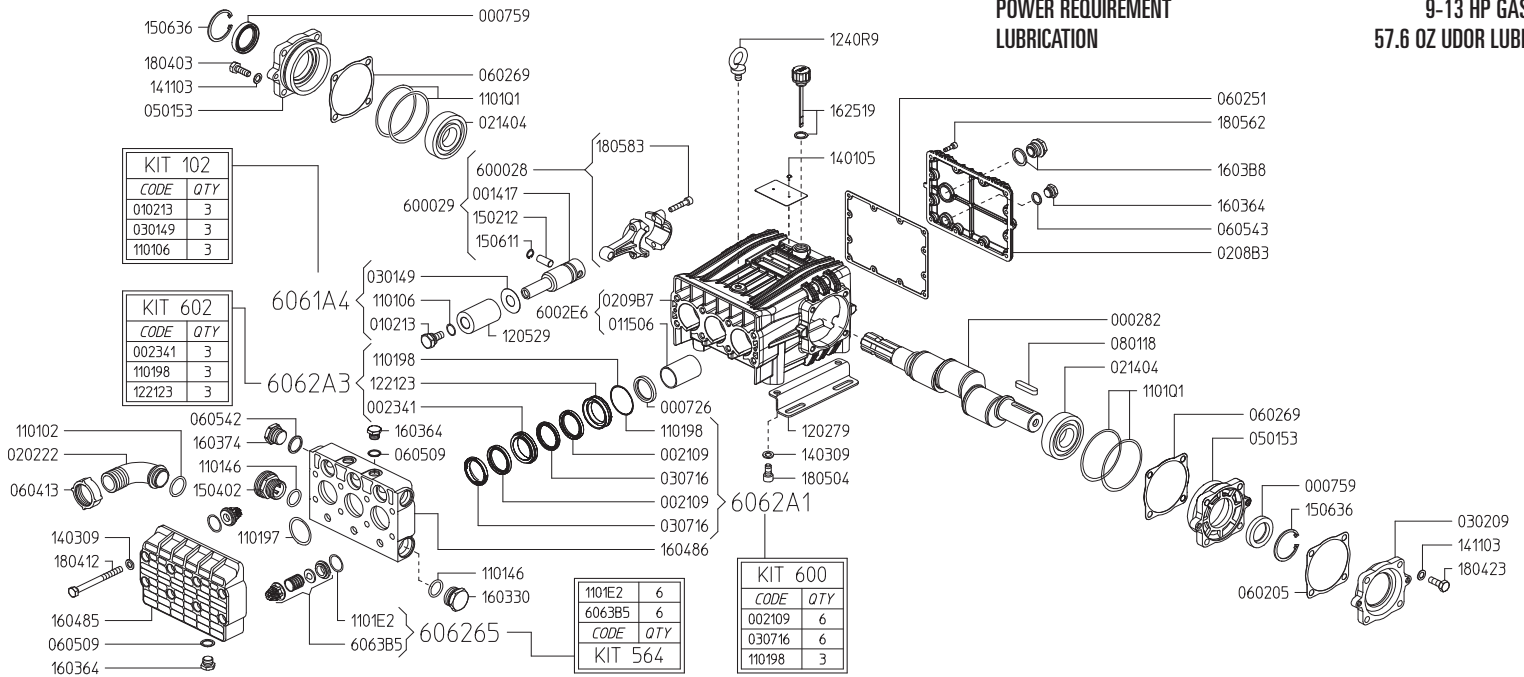

Revised 12-5-2024

Part #	Description	Qty
0002.82	SHAFT TSGR	1
0007.26	OIL SEAL D35	3
0007.59	OIL SEAL D35	2
0014.17	PLUNGER GUIDE	3
0021.09	WATER SEAL H.P. D40 ^C	6
0023.41	UPPER RING D40 ^D	3
0102.13	PISTON BOLT ^A	3
0115.06	BUSHING D35	3
0202.22	HOSE BARB D36	1
0208.B3	BACK COVER	1
0209.B7	CRANKCASE	1
0214.04	BALL BEARING D35	2
0301.49	DISC ^A	3
0302.09	BEARING FLANGE SPACER G62TSGR	1
0307.16	SPACER RING D40 ^C	6
0501.53	BEARING FLANGE	2
0602.05	GASKET - BEARING FLANGE SPACER	1
0602.51	BACK COVER GASKET	1
0602.69	FLANGE GASKET	2
0604.13	BRASS NUT M46X2	1
0605.09	GASKET D17	4
0605.42	GASKET D27	1
0605.43	GASKET D17	1
0801.18	KEY A10X8X32 UNI6604-69	1
1101.02	O-RING - INLET HOSE BARB	1
1101.06	O-RING - PLUNGER BOLT ^A	3
1101.46	O-RING - INLET PORT	2
1101.97	O-RING - SPLIT MANIFOLD	3
1101.98	O-RING - PRESSURE RING ^{C,D}	3
1101.E2	O-RING - VALVE ^B	6
1101.Q1	O-RING - BEARING FLANGE	4
1202.79	BASE PLATE	2
1205.29	CERAMIC PLUNGER D40	3
1221.23	PRESSURE RING D40 ^D	3

Part #	Description	Qty
1240.R9	LIFTING HOOK M10	1
1401.05	RIVET 3.5X8	2
1403.09	WASHER D10.5	12
1411.02	SERATED WASHER D8	6
1411.03	SERATED WASHER D10	8
1502.12	PIN D12X27.8	3
1504.02	BRASS INLET CONNECTOR	1
1506.11	SNAP RING D12	3
1506.36	SNAP RING D55	2
1603.30	PLUG G1"	1
1603.64	PLUG G3/8	5
1603.74	PLUG G3/4	1
1603.B8	OIL PLUG G3/4 + GASKET	1
1604.85	FRONT HEAD	1
1604.86	MIDDLE HEAD	1
1625.19	OIL PLUG G1/2 + GASKET	1
1804.03	HEX BOLT M10X30	4
1804.12	HEX BOLT M10X110	8
1804.23	HEX BOLT M10X40	4
1805.04	ALLEN BOLT M10X20	4
1805.23	ALLEN BOLT M8X40	6
1805.62	ALLEN BOLT M6X20	12
6000.28	ROD ASSEMBLY	3
6002.E6	CRANKCASE ASSEMBLY	1
6063.B5	VALVE ASSEMBLY W/O O-RING ^B	6
6061.A4	PLUNGER KIT(KIT 102)	1
6062.65	IN/OUTLET VALVE KIT (KIT 564)	1
6062.A1	WATER SEAL KIT (KIT 600)	1
6062.A3	BRASS RING KIT (KIT 602)	1

^A Parts in 6061.A4 (Kit 102).
^B Parts in 6062.65 (Kit 564).
^C Parts in 6062.A1 (Kit 600).
^D Parts in 6062.A3 (Kit 602).

**GAS ENGINE GEAR REDUCTION FOR
GAMMA-62 PLUNGER PUMPS**
on up to 16.0 HP GAS ENGINES with 1" SHAFTS
REQUIRES 17.25 OZ. 90W GEAR LUBE

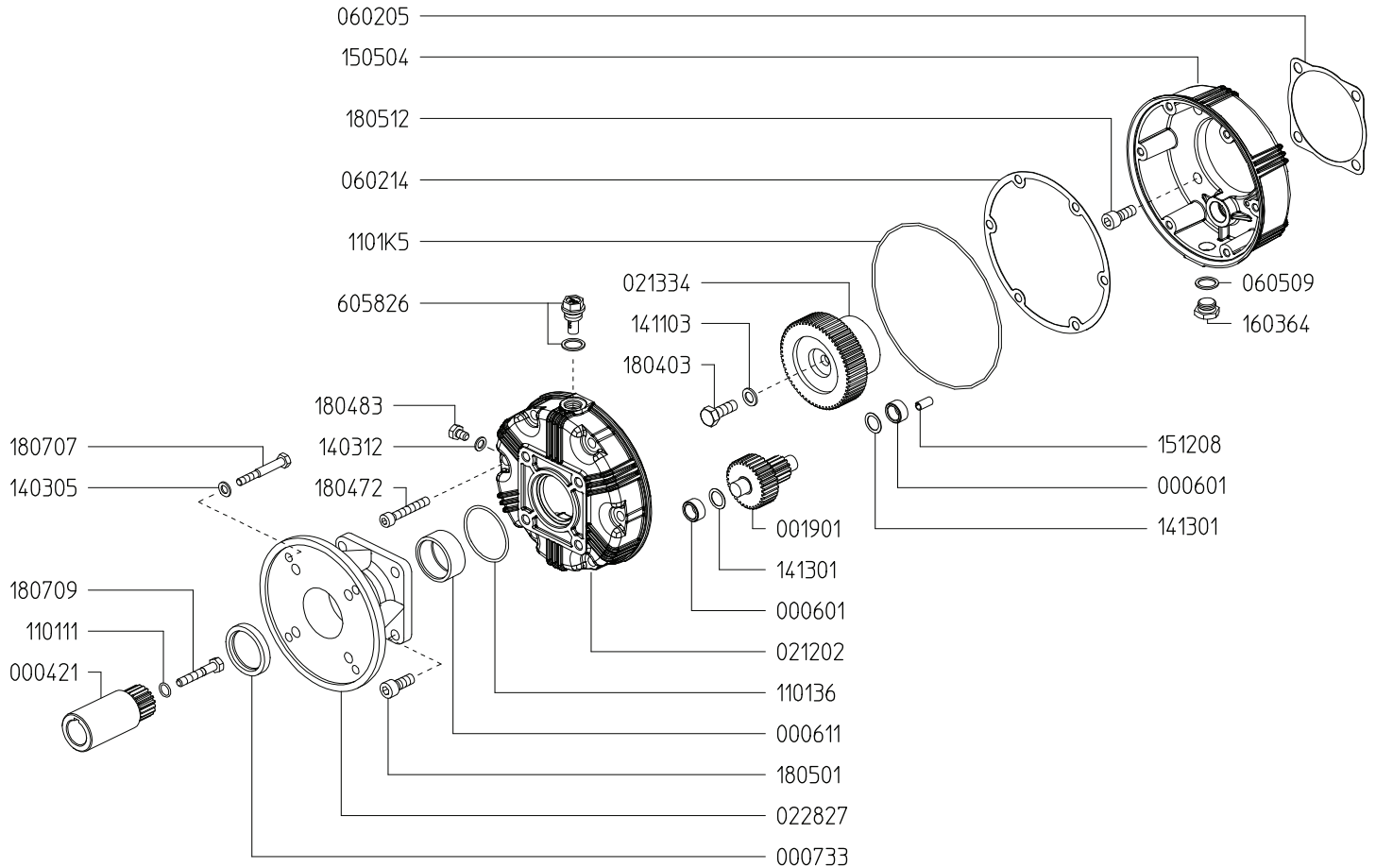

Revised 12-5-2024

Part #	Description	Qty	Part #	Description	Qty
0004.21	GEAR SHAFT "S164-1"	1	1403.05	WASHER D8.4	4
0006.01	BUSHING D15	2	1403.12	GASKET D8.5	1
0006.11	BUSHING D40	1	1413.01	WASHER D15	2
0007.33	OIL SEAL D40	1	1505.04	GEAR BODY "S164"	1
0019.01	GEAR SHAFT "S164"	1	1512.08	PLUG D4X16	1
0212.02	REDUCER COVER "S164"	1	1603.64	PLUG G3/8	1
0213.34	GEAR "S164-G62"	1	1804.03	HEX BOLT M10X30	1
0228.27	COUPLER "S164-VA"	1	1804.72	HEX BOLT M8X50	6
0602.05	GASKET	1	1804.83	HEX BOLT M8X12	1
0602.14	GASKET "S164"	1	1805.01	ALLEN BOLT M10X25	4
0605.09	GASKET D17	1	1805.07	ALLEN BOLT M10X40	4
1101.11	O-RING - GEAR SHAFT	1	1807.07	HEX BOLT 5/16X1" UNF	4
1101.36	O-RING - BUSHING	1	1807.09	HEX BOLT 5/16X2-1/4" UNF	1
1101.K5	O-RING - GEAR CASE	1	6058.26	OIL PLUG G3/8	1

GAMMA 62 DIMENSIONS

WEIGHT 49 LBS
 LUBRICATION 57.6 OZ UDOR LUBE
 SHAFT OPTIONS
 TS1C ... 1-3/8" 6-Spline Male PTO x 35mm Solid Keyed Thru-Shaft
 TS2C 1-3/8" 6-Spline Male PTO Thru-Shaft
 TSGR Replacement for GR Models

*Dimensional Drawings are
 Shown in Millimeters.
 To Convert to Inches,
 Multiply Dimension x 0.03937*

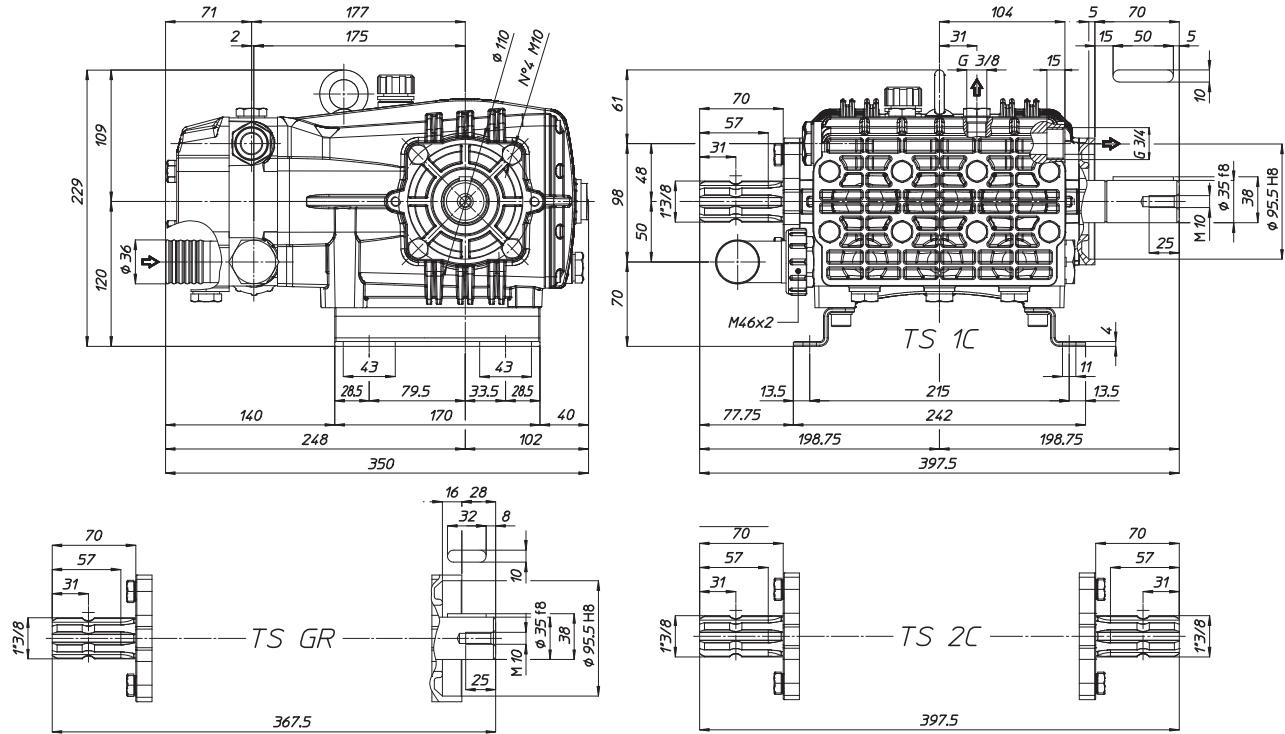

TORQUE SPECS

Ref.	Description	Ft./lb.	Nm	Loctite®
1	Head Bolts	37	50	-
2	Valve Caps	-	-	-
3	Inlet Cap	133	180	-
4	Outlet Cap	103	140	243
5	Bearing Flange Bolts	37	50	-
6	Rear Cover Bolts	8	11	-
7	Connecting Rod Bolts	19	25	243
8	Plunger Bolts	37	50	243
9	Valve Cover Bolts	-	-	-
10	Oil Drain Plug	8	11	-

