



DELTA 140

3-Cylinder, High-Pressure Diaphragm Pumps



DELTA 140 3-cylinder, high pressure diaphragm pumps are internally manifolded with anodized aluminum construction and anodized aluminum and stainless steel liquid handling parts. Includes mounting rails and 6005.05 control unit with pressure gauge.

DELTA 140 pumps are excellent choices for various horticultural, agricultural, lawn care, nursery, pest control and turf spraying applications. They are also effectively used for aircraft de-icing, hydrostatic testing and cleaning applications.

Model	GPM	l/min	PSI	bar	RPM	Drive Configuration	Weight
DELTA 140 TS2C	36.4	138.0	725	49	550	1-3/8" 6-Spline Male PTO Thru-Shaft	95 LBS
DELTA 140 TSMFVA	36.4	138.0	725	49	550	1-3/8" 6-Spline Male PTO x Universal VA Face	95 LBS
DELTA 140 GR1	36.4	138.0	725	49	550	Gear Reduction for Gas Engines with 1" Shaft, 8-20 HP	115 LBS

Specifications	DELTA 140	Description	Part #
Inlet Port	1-1/2" Hose Barb	Diaphragm Kit (GREENTECH)	6062.H5
Outlet Ports	(2) 1/2" Hose Barb	Diaphragm Bolt / Washer Kit	6062.16
Bypass	1" Hose Barb	Valve Kit	6062.H6
Piston Diameter	75mm	Regulator Repair Kit	6062.53
Crankshaft Stroke/Code	19.0mm / U	Complete Repair Kit	8700.83CK
Dimensions	19.0"L x 15.5"W x 14.5"H		

Lubrication: Requires 54 oz. of Udor Lube 40W Premium Pump Oil.
Alternate Oil: 30W non-detergent or 15W-40 non-detergent oil.



6180 140th Avenue NW
Ramsey, MN 55303

Ph: 651-785-0666
Fax: 800-732-2670

www.udorusa.com
www.boominator.com
info@udorusa.com



Scan this QR Code
for More Information



**D140
2024A**

Maximum Flow	36.4 GPM / 138 lpm
Maximum Pressure	725 PSI / 49 bar
Maximum RPM	550 RPM
Inlet Port	1-1/2" Hose Barb
Outlet Ports	(2) 1/2" Hose Barb Valve, 3/4" MPT
Bypass	1" Hose Barb
Dimensions	19.0"L x 15.5"W x 14.5"H
Weight	115 lbs

Lubrication: Requires 54 oz. of Udor Lube 40W Premium Pump Oil.
Alternate Oil: 30W non-detergent or 15W-40 non-detergent oil.

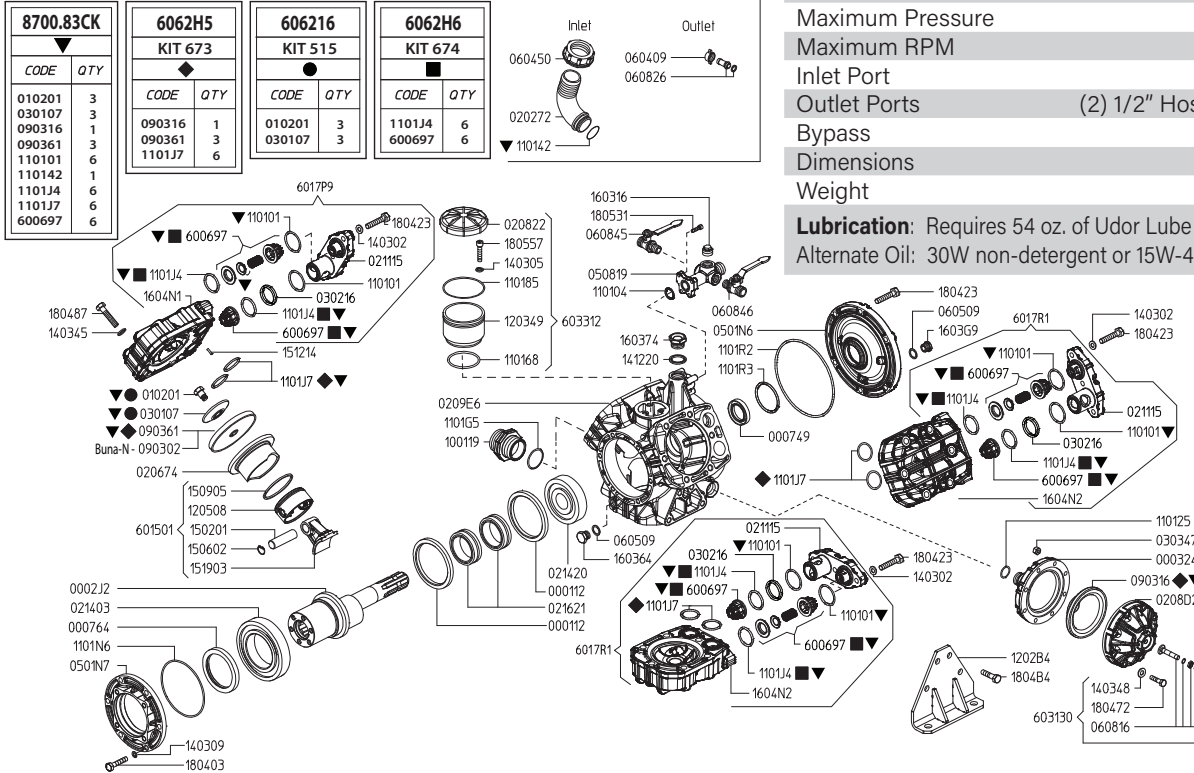

Revised 7-15-2024

Part #	Description	Qty	Part #	Description	Qty
0001.12	RETAINER RING "DELTA 140"	2	1101.R2	O-RING - CRANKCASE FLANGE	1
0002.J2	SHAFT "DELTA 140" TS MFVA	1	1101.R3	O-RING - CRANKCASE FLANGE	1
0003.24	PRESSURE ACCUMULATOR	1	1202.B4	BASE PLATE "DELTA 140"	2
0007.49	OIL SEAL D35	1	1203.49	OIL RESERVOIR	1
0007.64	OIL SEAL D75	1	1205.08	ALUMINIUM PISTON D75	3
0102.01	DIAPHRAGM BOLT ●▼	3	1403.02	WASHER D10.5	9
0202.72	HOSE BARB D40	1	1403.05	WASHER D8.4	3
0206.74	SLEEVE "DELTA 140"	3	1403.09	WASHER D10.5	6
0208.22	OIL RESERVOIR COVER	1	1403.45	WASHER D13	18
0208.D2	ACCUMULATOR COVER	1	1403.48	WASHER D8.4 DACROMET	8
0209.E6	PUMP BODY "DELTA 140"	1	1412.20	WASHER	1
0211.13	VALVE COVER "DELTA 140"	3	1502.01	PIN D18X64	3
0214.03	BALL BEARING D75	1	1506.02	SNAP RING D18	3
0214.20	BALL BEARING D35	1	1509.05	PISTON RING D75	3
0216.21	ROLLER BEARING D35	2	1512.14	PIN	3
0301.07	DIAPHRAGM DISC ●▼	3	1519.03	CONNECTING ROD	3
0302.16	SPACER	3	1603.16	PLUG G1/2	1
0303.47	HEX NUT M8X8	8	1603.64	OIL PLUG	1
0501.N6	CRANKCASE FLANGE "DELTA 140"	1	1603.74	PLUG	1
0501.N7	FLANGE "DELTA 140" TS MFVA	1	1604.N1	RIGHT HEAD "DELTA 140"	1
0508.19	BALL VALVE FLANGE "DELTA 140"	1	1604.N2	LEFT HEAD "DELTA 140"	2
0604.09	BRASS NUT G1/2	2	1804.03	HEX BOLT M10X30	6
0604.50	BARB NUT G1-1/2"	1	1804.23	HEX BOLT M10X40	15
0605.09	GASKET D17	1	1804.72	HEX BOLT M8X50	8
0608.16	AIR VALVE ASSEMBLY	1	1804.87	HEX BOLT	18
0608.26	HOSE BARB D13+GASKET	2	1804.B4	HEX BOLT	8
0608.45	BALL VALVE RIGHT	1	1805.31	ALLEN BOLT M6X30	4
0608.46	BALL VALVE LEFT	1	1805.57	ALLEN BOLT	3
0903.02	PISTON DIAPHRAGM 116MM BUNA-N	3	6006.97	VALVE ASSEMBLY W/O O-RING ■▼	6
0903.16	ACCUMULATOR DIAPHRAGM ◆▼	1	6015.01	ROD ASSY "DELTA 140" D75	3
0903.61	PISTON DIAPHRAGM 116MM GREENTECH ◆▼	3	6017.P9	HEAD ASSEMBLY - RIGHT	1
1001.19	INLET NIPPLE	1	6017.R1	HEAD ASSEMBLY - LEFT	2
1101.01	O-RING - VALVE COVER ▼	6	6031.30	PRESSURE ACCUMULATOR ASSEMBLY	1
1101.04	O-RING - BALL VALVE FLANGE	1	6033.12	OIL RESERVOIR ASSEMBLY	1
1101.25	O-RING - PRESSURE ACCUMULATOR	1	6062.16	DIAPHRAGM BOLT / WASHER (KIT 515)	1
1101.42	O-RING - INLET HOSE BARB ▼	1	6062.H5	DIAPHRAGM KIT - GREENTECH (KIT 673)	1
1101.68	O-RING - OIL RESERVOIR	1	6062.H6	IN/OUT VALVE KIT (KIT 674)	1
1101.85	O-RING - OIL RESERVOIR	1	8700.83CK	COMPLETE REPAIR KIT	1
1101.G5	O-RING - INLET NIPPLE	1	●	Parts in 6062.16 (Kit 515)	
1101.J4	O-RING - VALVE ■▼	6	◆	Parts in 6062.H5 (Kit 673)	
1101.J7	O-RING - HEAD, VITON ◆▼	6	■	Parts in 6062.H6 (Kit 674)	
1101.N6	O-RING - CRANKSHAFT FLANGE	1	▼	Parts in 8700.83CK (Complete Repair Kit)	

**GAS ENGINE GEAR REDUCTION FOR
DELTA 100/DELTA 140 DIAPHRAGM PUMPS
on GAS ENGINES with 1" SHAFTS
REQUIRES 28 OZ. 90W GEAR LUBE**

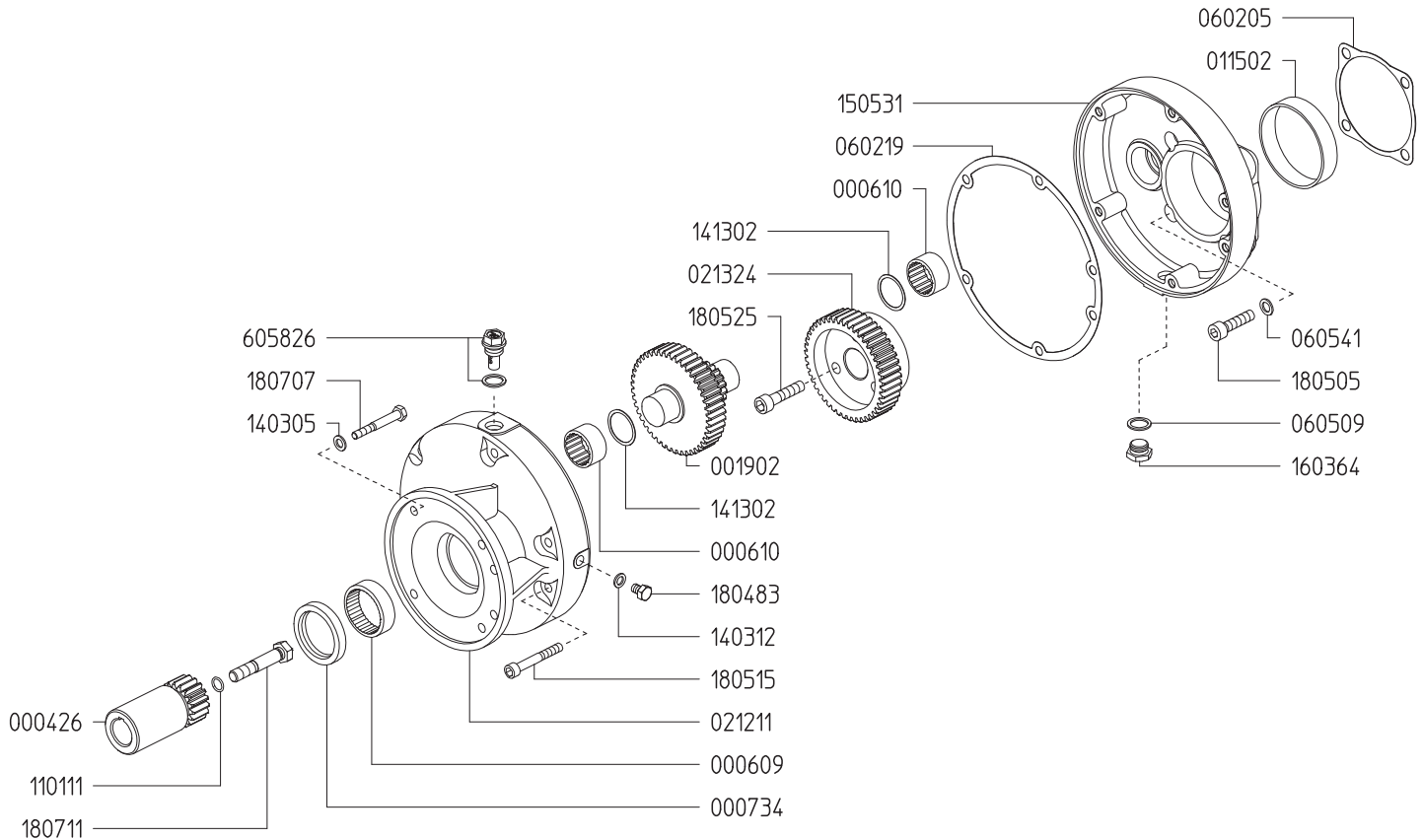

Revised 7-15-2024

Part #	Description	Qty	Part #	Description	Qty
0004.26	GEAR SHAFT "M162-1"VA"	1	1403.05	WASHER D8.4	4
0006.09	BUSHING D45	1	1403.12	GASKET D8.5	1
0006.10	BUSHING D30	2	1413.02	WASHER D30	2
0007.34	OIL SEAT D45	1	1505.31	GEAR BODY "M162"	1
0019.02	GEAR SHAFT "M162"	1	1603.64	PLUG G3/8	1
0115.02	BUSHING D80 GLY	1	1804.83	HEX BOLT M8X12	1
0212.11	REDUCER COVER "M162"	1	1805.05	ALLEN BOLT M10X30	4
0213.24	RED.GEAR WHEEL Z=45 "M162-VA"	1	1805.15	ALLEN BOLT M8X60	6
0602.05	GASKET	1	1805.25	ALLEN BOLT M10X45	3
0602.19	GASKET "M162"	1	1807.07	HEX BOLT 5/16X1" UNF	4
0605.09	GASKET D17	1	1807.11	HEX BOLT 7/16"X2" UNF	1
0605.41	GASKET D10	4	6058.26	OIL PLUG G3/8	1
1101.11	O-RING - GEAR SHAFT	1			

Adjustable Pressure Regulator

Maximum Flow	47.3 GPM / 179.2 lpm
Maximum Pressure	1200 PSI / 81 bar
Inlet Port	3/4" Male BSP
Outlet Ports	-
Bypass - Hose Barb	1" HB

606254	
KIT 553	
■	
CODE	QTY
090325	1
110101	1
110131	1
120413	1
150125	1
181001	1

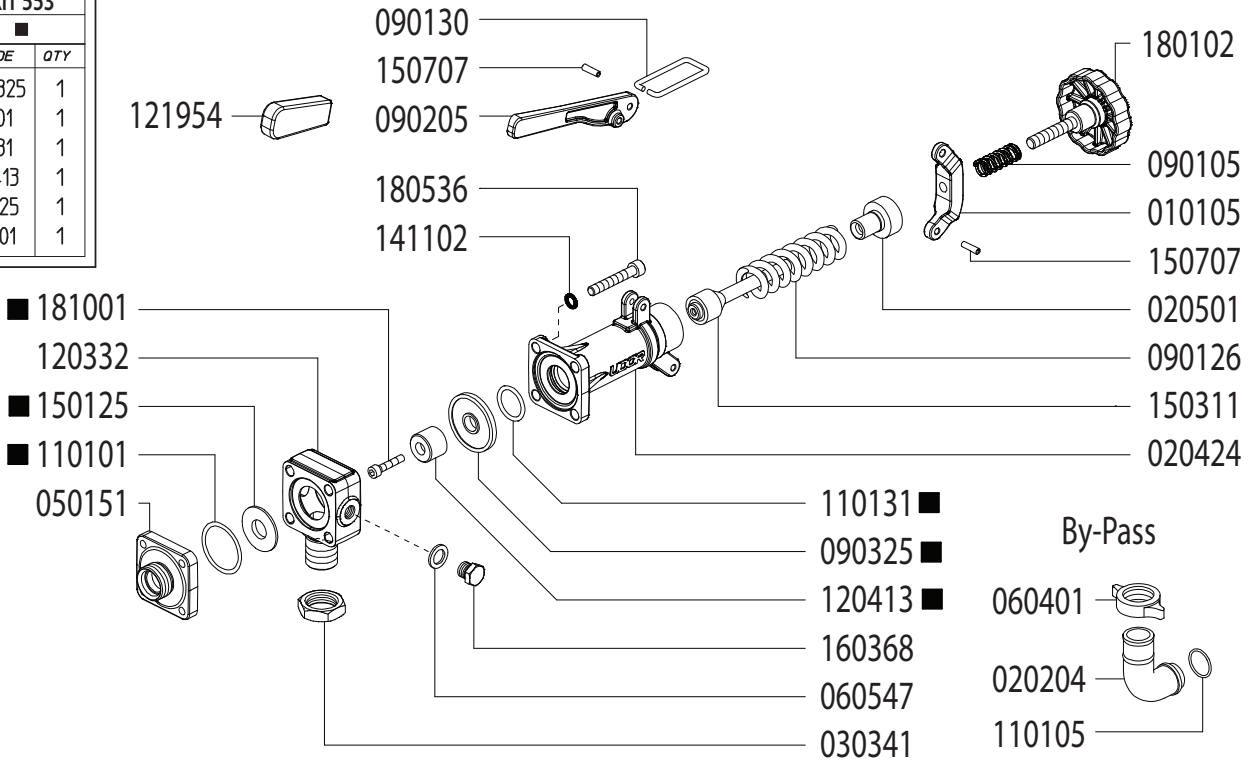

Revised 7-15-2024

Part #	Description	Qty
0101.05	LEVER GUIDE	1
0202.04	1" BRASS ELBOW HOSE BARB	1
0204.24	VALVE BODY	1
0205.01	VALVE CYLINDER	1
0303.41	NUT	1
0501.51	FLANGE	1
0604.01	BARB NUT	1
0605.47	GASKET D8	1
0901.05	SPRING	1
0901.30	PRESSURE BAIL	1
0901.26	SPRING	1
0902.05	HANDLE	1
0903.25 ■	DIAPHRAGM	1
1101.01 ■	O-RING - BYPASS FLANGE	1
1101.05	O-RING - BYPASS HOSE BARB	1

Part #	Description	Qty
1101.31 ■	O-RING - VALVE BODY	1
1203.32	INLET ELBOW - 3/4" MALE BSP	1
1204.13	POPPET ■	1
1219.54	HANDLE COVER - RUBBER	1
1501.25	SEAT ■	1
1503.11	REGULATOR STEM	1
1507.07	PIN	2
1603.68	PLUG - 1/4" BRASS	1
1801.02	ADJUSTMENT KNOB	1
1805.36	BOLT	4
1810.01	BOLT - STAINLESS STEEL ■	1
GG1500	HIGH PRESSURE GAUGE (OPTIONAL)	1
6062.54	REPAIR KIT (KIT 553)	

■ Parts Included in Repair Kit #6062.54 (KIT 553)

OPERATING INSTRUCTIONS

1. Before operating or re-operating pump, lift R.V. Handle (0902.05) so pump will start at zero pressure.
FAILURE TO DO SO WILL VOID PUMP WARRANTY.
2. Turn Pressure Adjustment Knob (1801.02) counter-clockwise to relieve spring tension. (Step 2 is only necessary on initial start-up and is not necessary for daily operation.)
3. Start unit and let run until air is evacuated from system, when only liquid is expelled from the bypass line.
4. Return R.V. Handle (0902.05) to down position. Open spray gun or spray boom and turn adjustment knob (1801.02) clockwise until desired operating pressure is achieved.

DELTA 140 DIMENSIONS

All Dimensions are WITHOUT Control Unit or Regulator

Dimensional Drawings are Shown in Millimeters. To Convert to Inches, Multiply Dimension x 0.03937

Specifications

DELTA 140

Inlet Port - Hose Barb	1-1/4" HB
Outlet Ports - Hose Barb	(2) 1/2" HB
Bypass - Hose Barb	3/4" HB
Dimensions	19.0" L x 15.5" W x 14.5" H
Diaphragm Material	GREENTECH (Std) Buna-N (Opt)

Lubrication: Requires 54 oz. of Udor Lube 40W Premium Pump Oil.
Alternate Oil: 30W non-detergent or 15W-40 non-detergent oil.

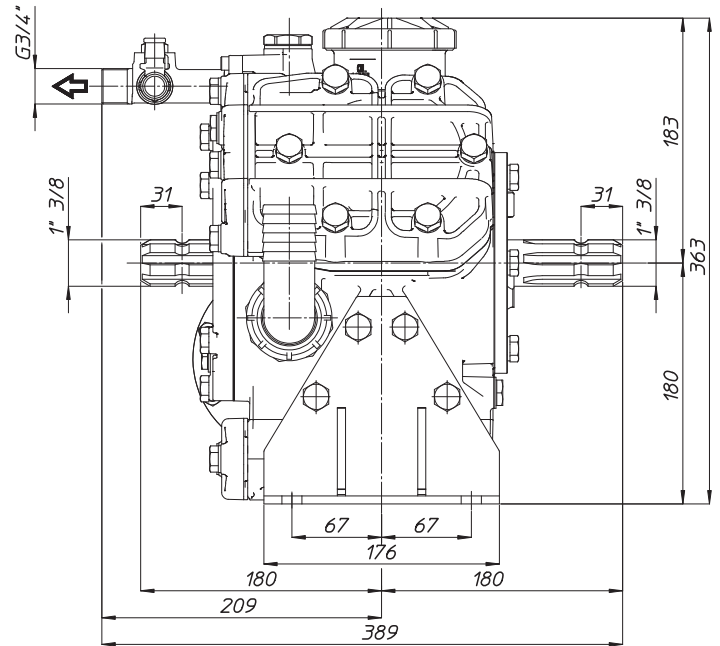
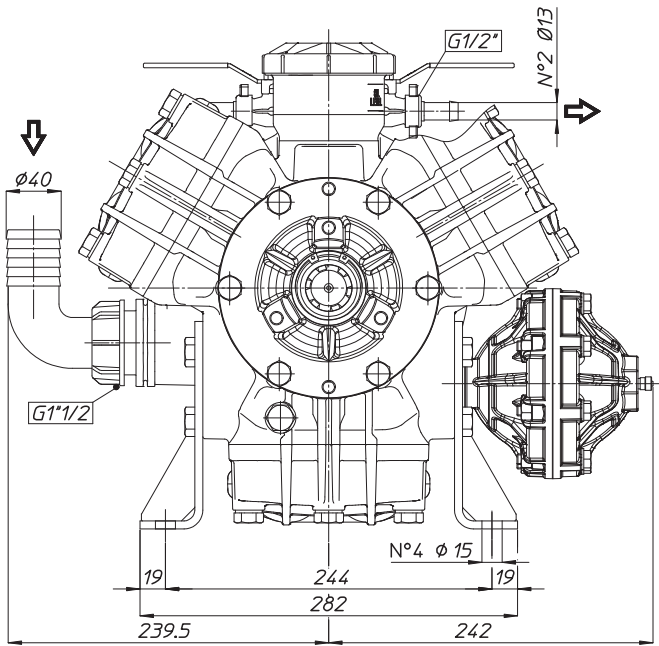

TORQUE SPECS

Ref.	Description	Ft./lb.	Nm
1	Diaphragm Bolts (Use Loctite 243)	23	30
2	Head Bolts	37	90
3	Pulsation Dampener Bolts	18	25
4	Inlet Flange Bolts	36	50
5	Bearing Flange Bolts	36	50
6	Oil Cup Bolts	7	10
7	Valve Cover Bolts	36	50

