

## 5-Cylinder, Medium-Pressure Diaphragm Pumps

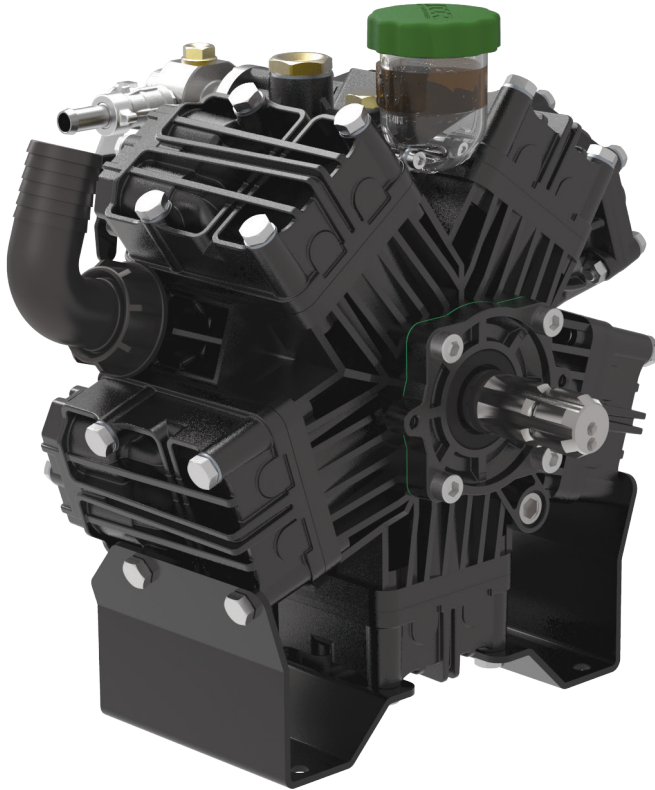

DELTA 125 5-cylinder, medium pressure diaphragm pumps are internally manifolded with anodized aluminum construction and anodized aluminum and stainless steel liquid handling parts.

DELTA 125 pumps are excellent choices for various horticultural, agricultural, lawn care, nursery, pest control and turf spraying applications. They are also effectively used for aircraft de-icing, hydrostatic testing and cleaning applications.

Model	GPM	l/min	PSI	bar	RPM	Drive Configuration	Weight
DELTA 125 1C	34.0	126.0	560	40	550	1-3/8" 6-Spline Male PTO Shaft	65 LBS
DELTA 125 VA	34.0	126.0	560	40	550	Universal VA Drive Face. Mounting Rails	65 LBS
DELTA 125 TSVA	34.0	126.0	560	40	550	Universal VA Drive Face x 1-3/8" 6-Spline Male PTO	65 LBS
DELTA 125 TS2C	34.0	126.0	560	40	550	1-3/8" 6-Spline Male PTO Thru-Shaft	65 LBS
DELTA 125 VAGR1	34.0	126.0	560	40	550	Gear Reduction for Gas Engines with 1" Shaft, 8-20 HP	85 LBS

Specifications	DELTA 125	Description	Part #
Inlet Port	1-1/4" Hose Barb	Diaphragm Kit (GREENTECH)	6062.F7
Outlet Ports	(2) 1/2" Hose Barb, 3/4" MBSP	Diaphragm Bolt / Washer Kit	6062.87
Bypass	3/4" Hose Barb	Valve Kit	6062.F8
Piston Diameter	60mm	Regulator Repair Kit	6062.53
Crankshaft Stroke/Code	170mm / G	Complete Repair Kit	8700.82CK
Dimensions	14.0"L x 18.0"W x 16.0"H		

**Lubrication:** Requires 69 oz. of Udor Lube 40W Premium Pump Oil.  
Alternate Oil: 30W non-detergent or 15W-40 non-detergent oil.



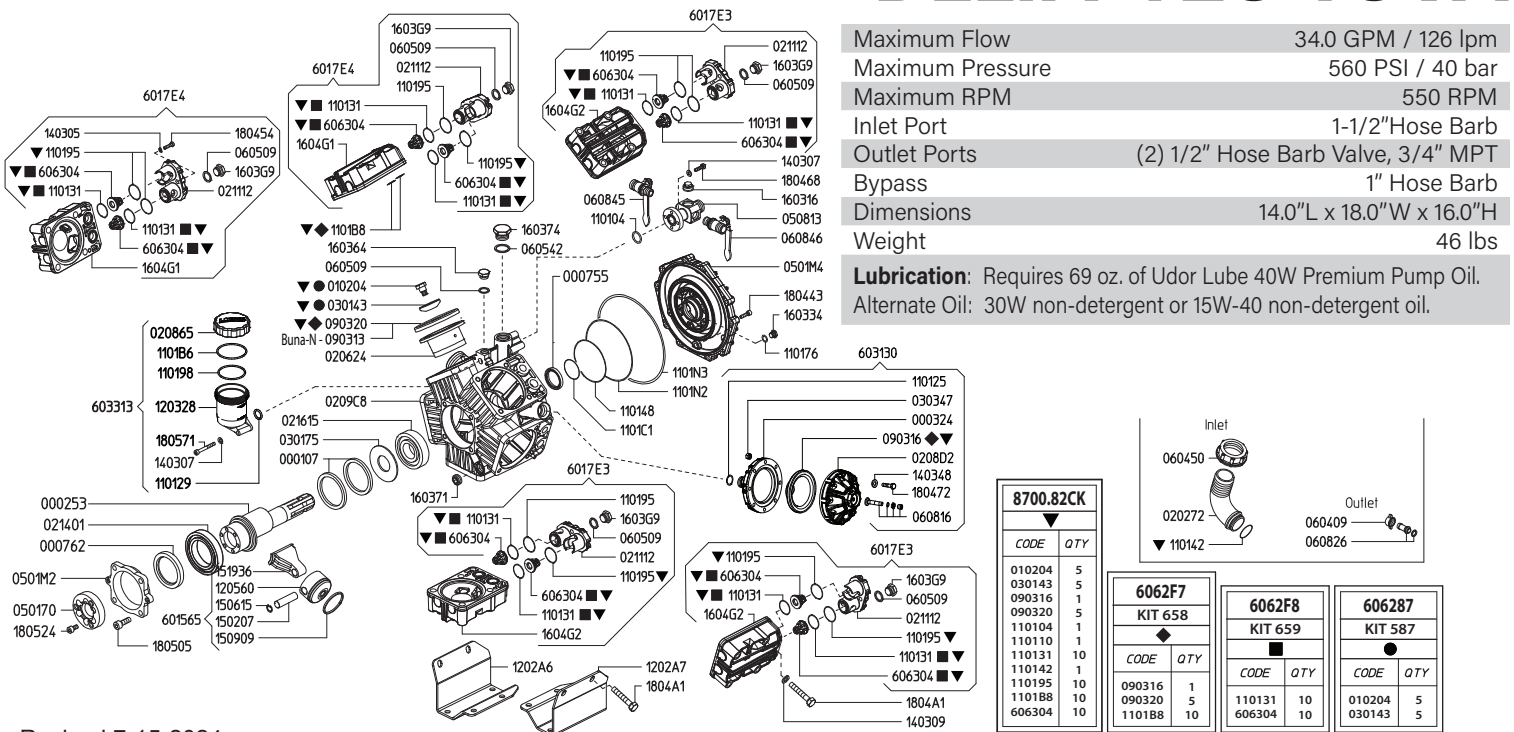

**Maximum Flow** 34.0 GPM / 126 lpm  
**Maximum Pressure** 560 PSI / 40 bar  
**Maximum RPM** 550 RPM  
**Inlet Port** 1-1/2" Hose Barb  
**Outlet Ports** (2) 1/2" Hose Barb Valve, 3/4" MPT  
**Bypass** 1" Hose Barb  
**Dimensions** 14.0"L x 18.0"W x 16.0"H  
**Weight** 46 lbs  
**Lubrication:** Requires 69 oz. of Udor Lube 40W Premium Pump Oil.  
 Alternate Oil: 30W non-detergent or 15W-40 non-detergent oil.

Revised 7-15-2024

Part #	Description	Qty	Part #	Description	Qty
0001.07	RETAINER RING	2	1101.N2	O-RING - CRANKCASE FLANGE	1
0002.53	SHAFT - TS VA	1	1101.N3	O-RING - CRANKCASE FLANGE	1
0003.24	PRESSURE ACCUMULATOR	1	1202.A6	LEFT BASE PLATE	1
0007.55	OIL SEAL D35	1	1202.A7	RIGHT BASE PLATE	1
0007.62	OIL SEAL D60	1	1203.28	OIL RESERVOIR	1
0102.04	DIAPHRAGM BOLT ●▼	5	1205.60	ALUMINIUM PISTON D60	5
0202.72	HOSE BARB D40	1	1403.05	WASHER M8	10
0206.24	SLEEVE D60	5	1403.07	WASHER M6	6
0208.65	OIL RESERVOIR COVER	1	1403.09	WASHER M10	16
0208.D2	PRESSURE ACCUMULATOR COVER	1	1403.48	WASHER M8	8
0209.C8	CRANKCASE	1	1502.07	PIN D15X54	5
0211.12	VALVE COVER	5	1506.15	SNAP RING D15	5
0214.01	BALL BEARING D60	1	1509.09	PISTON RING D60	5
0216.15	ROLLER BEARING D35	1	1519.36	CONNECTING ROD	5
0301.43	DIAPHRAGM DISC ●▼	5	1603.16	PLUG G1/2	1
0301.75	BEARING DISC	1	1603.34	PLUG G1/4	1
0303.47	HEX NUT M8X8	8	1603.64	PLUG G3/8	1
0501.70	FLANGE "DELTA 75/100" VA	1	1603.71	PLUG G1/2	1
0501.M2	FLANGE "DELTA 75/100" VA	1	1603.G9	HEAD PLUG 3/8	5
0501.M4	CRANKCASE FLANGE	1	1604.G1	RIGHT HEAD	2
0508.13	FLANGE G3/4 M - G3/8 F	1	1604.G2	LEFT/BOTTOM HEAD	3
0604.09	BRASS NUT G1/2	1	1804.43	HEX BOLT M6X35	10
0604.50	BARB NUT G1-1/2"	1	1804.54	HEX BOLT M8X35	10
0605.09	GASKET D17	6	1804.68	HEX BOLT M6X22	4
0608.16	AIR VALVE ASSEMBLY	1	1804.72	HEX BOLT M8X50	8
0608.26	HOSE BARB D13+GASKET	1	1804.A1	HEX BOLT M10X70	20
0608.45	BALL VALVE RIGHT	1	1805.05	ALLEN BOLT M10X30	4
0608.46	BALL VALVE LEFT	1	1805.24	ALLEN BOLT M8X16	3
0903.20	PISTON DIAPHRAGM D100 BUNA-N	5	1805.71	ALLEN BOLT M6X50	2
0903.16	ACCUMULATOR DIAPHRAGM ■▼	1	6015.65	ROD ASSY D60	5
0903.20	PISTON DIAPHRAGM D100 GREENTECH ■▼	5	6017.E3	HEAD ASSEMBLY - LEFT/BOTTOM	3
1101.04	O-RING - DISCHARGE FLANGE	1	6017.E4	HEAD ASSEMBLY - RIGHT	2
1101.25	O-RING - PRESSURE ACCUMULATOR	1	6031.30	PRESSURE ACCUMULATOR ASSEMBLY	1
1101.29	O-RING - OIL RESERVOIR	1	6033.13	OIL RESERVOIR ASSEMBLY	1
1101.31	O-RING - VALVE ■▼	10	6063.04	VALVE ASSEMBLY W/O O-RING ◆▼	10
1101.42	O-RING - INLET HOSE BARB ▼	1	6062.87	DIAPHRAGM BOLT/WASHER KIT (KIT 587)	1
1101.48	O-RING - CRANKCASE FLANGE	1	6062.F7	DIAPHRAGM KIT - GREENTECH (KIT 658)	1
1101.76	O-RING - PLUG	1	6062.F8	IN/OUTLET VALVE KIT(KIT 659)	1
1101.95	O-RING - VALVE COVER ▼	10	8700.82CK	COMPLETE REPAIR KIT	1
1101.98	O-RING - OIL RESERVOIR	1			
1101.B6	O-RING - OIL RESERVOIR	1			
1101.B8	O-RING - HEAD ◆▼	10			
1101.C1	O-RING - CRANKCASE FLANGE	1			

- Parts in 6062.87 (Kit 587).
- Parts in 6062.F7 (Kit 658).
- ◆ Parts in 6062.F8 (Kit 659).
- ▼ Parts in 8700.82CK (Complete Repair Kit).

## Adjustable Pressure Regulator

Maximum Flow	47.3 GPM / 179.2 lpm
Maximum Pressure	1200 PSI / 81 bar
Inlet Port	3/4" Male BSP
Outlet Ports	-
Bypass - Hose Barb	1" HB

<b>606254</b>	
<b>KIT 553</b>	
■	
<b>CODE</b>	<b>QTY</b>
090325	1
110101	1
110131	1
120413	1
150125	1
181001	1

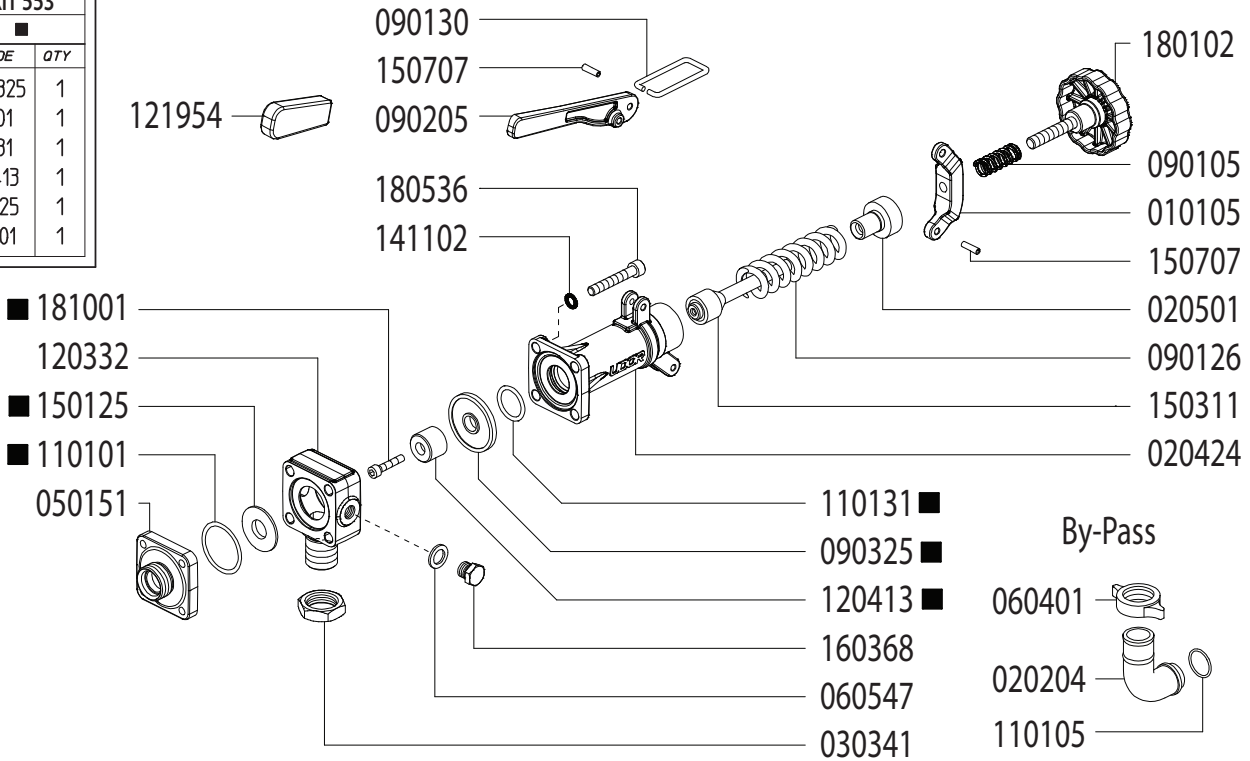

Revised 7-15-2024

Part #	Description	Qty
0101.05	LEVER GUIDE	1
0202.04	1" BRASS ELBOW HOSE BARB	1
0204.24	VALVE BODY	1
0205.01	VALVE CYLINDER	1
0303.41	NUT	1
0501.51	FLANGE	1
0604.01	BARB NUT	1
0605.47	GASKET D8	1
0901.05	SPRING	1
0901.30	PRESSURE BAIL	1
0901.26	SPRING	1
0902.05	HANDLE	1
0903.25 ■	DIAPHRAGM	1
1101.01 ■	O-RING - BYPASS FLANGE	1
1101.05	O-RING - BYPASS HOSE BARB	1

Part #	Description	Qty
1101.31 ■	O-RING - VALVE BODY	1
1203.32	INLET ELBOW - 3/4" MALE BSP	1
1204.13	POPPET ■	1
1219.54	HANDLE COVER - RUBBER	1
1501.25	SEAT ■	1
1503.11	REGULATOR STEM	1
1507.07	PIN	2
1603.68	PLUG - 1/4" BRASS	1
1801.02	ADJUSTMENT KNOB	1
1805.36	BOLT	4
1810.01	BOLT - STAINLESS STEEL ■	1
GG1500	HIGH PRESSURE GAUGE (OPTIONAL)	1
6062.54	REPAIR KIT (KIT 553)	

■ Parts Included in Repair Kit #6062.54 (KIT 553)

### OPERATING INSTRUCTIONS

1. Before operating or re-operating pump, lift R.V. Handle (0902.05) so pump will start at zero pressure.  
**FAILURE TO DO SO WILL VOID PUMP WARRANTY.**
2. Turn Pressure Adjustment Knob (1801.02) counter-clockwise to relieve spring tension. (Step 2 is only necessary on initial start-up and is not necessary for daily operation.)
3. Start unit and let run until air is evacuated from system, when only liquid is expelled from the bypass line.
4. Return R.V. Handle (0902.05) to down position. Open spray gun or spray boom and turn adjustment knob (1801.02) clockwise until desired operating pressure is achieved.

All Dimensions are WITHOUT Control Unit or Regulator

Dimensional Drawings are Shown in Millimeters. To Convert to Inches, Multiply Dimension x 0.03937

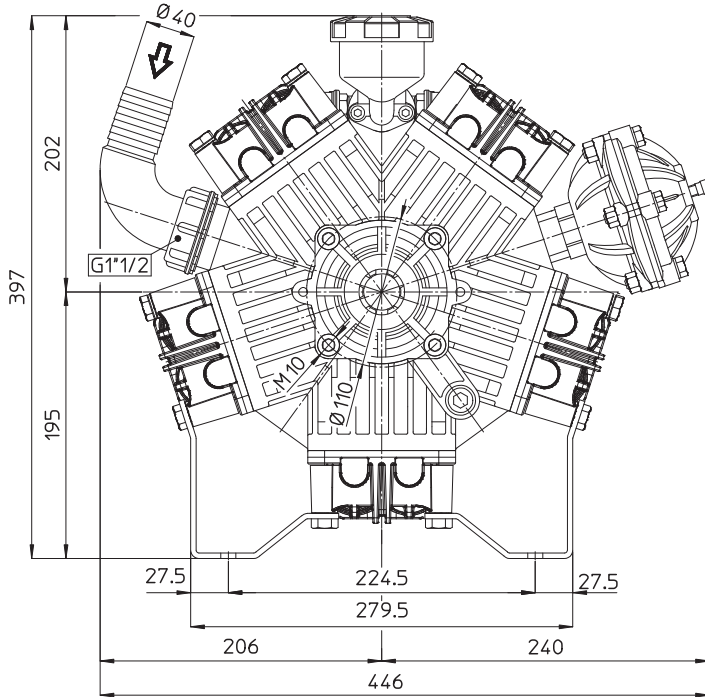

Specifications	DELTA 125
Inlet Port - Hose Barb	1-1/4" HB
Outlet Ports - Hose Barb	(2) 1/2" HB
Bypass - Hose Barb	3/4" HB
Dimensions	14.0" L x 18.0" W x 16.0" H
Diaphragm Material	GREENTECH (Std) Buna-N (Opt)

**Lubrication:** Requires 69 oz. of Udor Lube 40W Premium Pump Oil. Alternate Oil: 30W non-detergent or 15W-40 non-detergent oil.

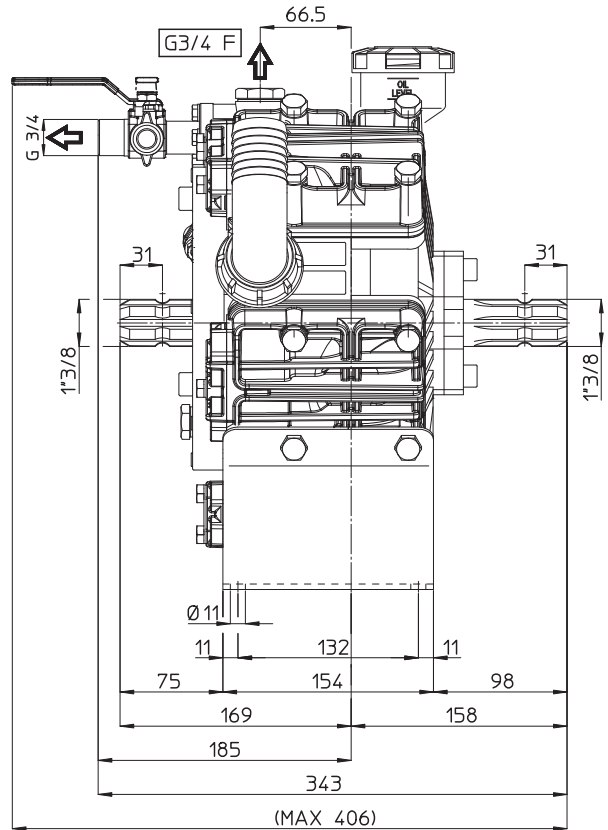

## TORQUE SPECS

Ref.	Description	Ft./lb.	Nm
1	Diaphragm Bolts (Use Loctite 243)	18	25
2	Head Bolts	30	40
3	Pulsation Dampener Bolts	20	28
4	Inlet Flange Bolts	7	10
5	Bearing Flange Bolts	25	34
6	Oil Cup Bolts	6	8
7	Valve Cover Bolts	18	25

