

Gear Reduction, Gas Engine Models

1" or 1-1/8" Hollow Shaft, SAE J609-B Flange
2.2:1 Gear Reduction Drive

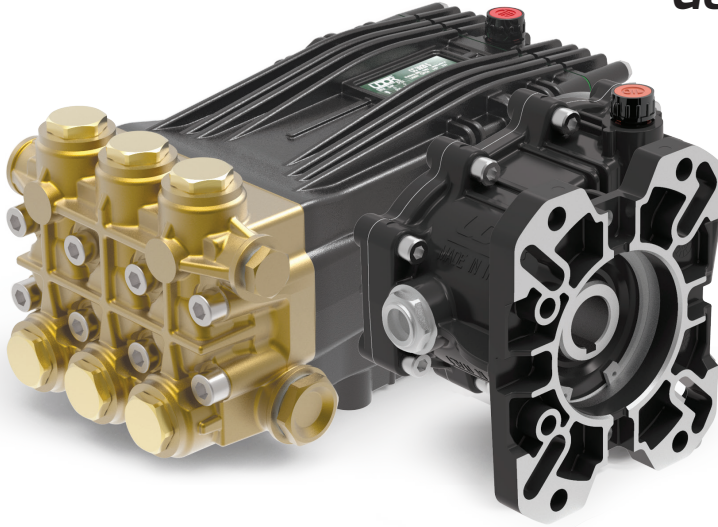

- Heavy Duty Brass Manifold with External and Internal Bracing
- Heavy Duty Bronze or Aluminum Connecting Rods
- Large Diameter Brass or Stainless Steel Valve Caps with Increased Thread Depth
- Reinforcing Ring on Inlet and Discharge Ports
- Stainless Steel Piston Guides and Check Valves
- Heat Treated Crank Shaft
- Industrial Quality Tapered Roller Bearings
- Deeper Back Cover for Increased Oil Capacity
- 34.5 oz. Capacity Vented Oil Bath Crank Case
- 3/4" BSP-F Inlet. 3/8" BSP-F Outlet - Less Than 10 GPM
- 3/4" BSP-F Inlet. 1/2" BSP-F Outlet - 10 GPM and Above
- Max Fluid Temp, 160°F

CKC Series Gas Engine, Gear Reduction Drive Plunger Pumps

CKC Series super duty plunger pumps include a wide range of models with flow rates from 4.5 to 12.0 GPM and pressures up to 5075 PSI.

Other drive options include 24mm solid shaft and hydraulic motor flange.

Applications include general pressure cleaning, sewer jetting, vehicle wash equipment, street cleaning, construction, hydro-excavation and UHP fire fighting applications.

	Model	Flow		Pressure		Plunger Dia.	Crankshaft		Power	Seal Kit	Valve Kit	Wt.
		GPM	l/min	PSI	bar		Stroke	Code				
Gear Reduction	CKC 17/30 GR	4.5	17.0	4350	300	22mm	11.0mm	P	18.0 HP Gas	6061.10	6061.03	39 lbs
	CKC 17/36 GR	4.5	17.0	5075	360	20mm	13.5mm	N	20.0 HP Gas	6061.D4	6061.63	39 lbs
	CKC 21/30 GR	5.5	21.0	4350	300	22mm	13.5mm	N	23.0 HP Gas	6061.10	6061.03	39 lbs
	CKC 21/36 GR	5.5	21.0	5075	360	20mm	17.0mm	X	24.0 HP Gas	6061.D4	6061.63	39 lbs
	CKC 26/30 GR	6.9	26.0	4350	300	22mm	17.0mm	X	26.0 HP Gas	6061.10	6061.03	39 lbs
	CKC 30/24 GR	7.9	30.0	3480	240	25mm	15.0mm	V	26.0 HP Gas	6061.11	6061.03	39 lbs
	CKC 30/30 GR	7.9	30.0	4350	300	22mm	19.0mm	Y	26.0 HP Gas	6061.10	6061.03	39 lbs
	CKC 34/25 GR	9.0	34.0	3625	250	25mm	17.0mm	X	26.0 HP Gas	6061.11	6061.03	39 lbs
	CKC 38/20 GR	10.0	38.0	2900	200	28mm	15.0mm	V	25.0 HP Gas	6061.12	6061.03	39 lbs
	CKC 42/20 GR	11.6	44.0	2900	200	28mm	17.0mm	X	26.0 HP Gas	6061.12	6061.03	39 lbs
	CKC 50/20 GR	13.2	50.0	2900	200	28mm	19.0mm	Y	26.0 HP Gas	6061.12	6061.03	39 lbs

NOTE: All models available with 1" or 1-1/8" Hollow Shafts . Specify size when ordering (ex. **CKC 21/30 GR1** or **CKC 21/30 GR1-1/8.**)



MAX FLOW 4.5 GPM / 17.0 L/MIN
MAX PRESSURE 4350 PSI / 300 BAR
RATED PUMP SPEED 1450 RPM
POWER REQUIREMENT 18.0 HP GAS
LUBRICATION 34.5 OZ UDOR LUBE

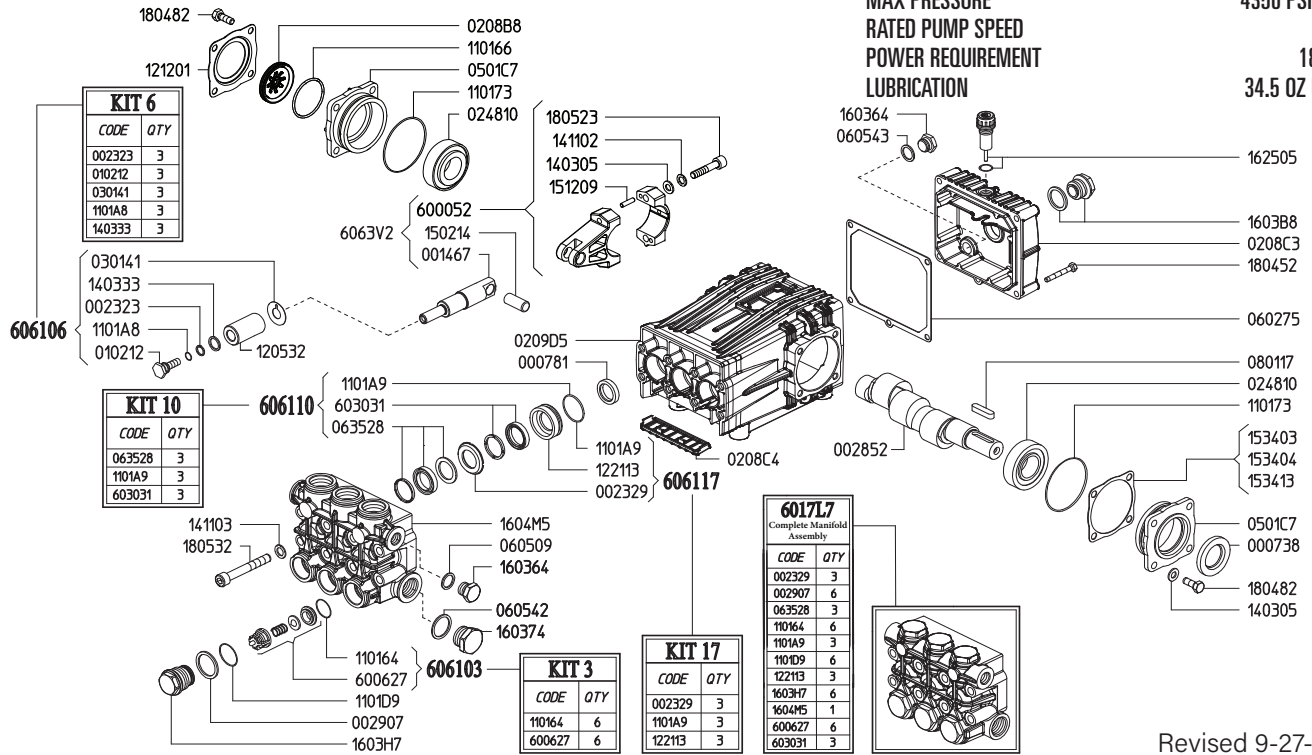

Revised 9-27-2024

Part #	Description	Qty	Part #	Description	Qty
0007.38	OIL SEAL D30	1	1403.33	WASHER D13.4 ^B	3
0007.81	OIL SEAL D20	3	1411.02	SERATED WASHER D8	6
0014.67	PLUNGER GUIDE D22/25/28 "C/CK"	3	1411.03	SERATED WASHER D10	8
0023.23	RING D10.4 ^B	3	1502.14	PIN D14X32	3
0023.29	UPPER RING D22 "CK" ^{D E}	3	1512.09	PLUG D5X20 UNI1707	6
0028.52	MALE SHAFT D24	1	1534.03	SHIM 0.1MM	-
0029.07	PLUG RING "CK" ^E	6	1534.04	SHIM 0.2MM	-
0102.12	PLUNGER BOLT ^B	3	1534.13	SHIM 0.05MM	-
0208.B8	OIL SIGHT GLASS	1	1603.64	PLUG G3/8	2
0208.C3	BACK COVER "C/CK"	1	1603.74	PLUG G3/4	1
0208.C4	COVER "CK"	1	1603.B8	OIL PLUG G3/4 + GASKET	1
0209.D5	CRANKCASE "C/CK/CH"	1	1603.H7	VALVE PLUG "CK" PISTON D22/25 ^E	6
0248.10	ROLLER BEARING D30	2	1604.M5	HEAD "CK" D22/25 ^E	1
0301.41	SLINGER RING ^B	3	1625.05	OIL PLUG G3/8	1
0501.C7	BEARING HOLLOW FLANGE	2	1804.52	HEX BOLT M6X45	5
0602.75	BACK COVER GASKET	1	1804.82	HEX BOLT M8X22	8
0605.09	GASKET D17	1	1805.23	ALLEN BOLT M8X40	6
0605.42	GASKET D27	1	1805.32	ALLEN BOLT M10X75	8
0605.43	GASKET D17	1	6000.52	ROD ASSEMBLY	3
0635.28	HIGH PRESS. SEAL KIT D22 ^{C E}	3	6006.27	VALVE ASSEMBLY W/O O-RING ^{A E}	6
0801.17	KEY A8X7X35 UNI6604	1	6017.L7	COMPLETE MANIFOLD ASSEMBLY	1
1101.64	O-RING - VALVE ^{A E}	6	6030.31	LOW PRESSURE SEAL KIT D22 ^{C E}	3
1101.66	O-RING - OIL SIGHT GLASS	1	6061.03	KIT 3 VALVE KIT	1
1101.73	O-RING - BEARING FLANGE	2	6061.06	KIT 6 PLUNGER KIT D22	1
1101.A8	O-RING - PLUNGER BOLT ^B	3	6061.10	KIT 10 WATER SEAL KIT D22 "C/CK"	1
1101.A9	O-RING - PRESSURE RING ^{C D E}	3	6061.17	KIT 17 BRASS RING KIT D22 "CK" 350BAR	1
1101.D9	O-RING - VALVE PLUG ^E	6			
1205.32	CERAMIC PLUNGER D22	3			
1212.01	RETAINER - OIL SIGHT GLASS	1			
1221.13	PRESSURE RING D22 ^{D E}	3			
1403.05	WASHER D8.4	10			

^A Parts in 6061.03 (Kit 3).
^B Parts in 6061.06 (Kit 6).
^C Parts in 6061.10 (Kit 10).
^D Parts in 6061.17 (Kit 17).
^E Parts in 6017.L7 (Complete Manifold Assembly).

**GAS ENGINE GEAR REDUCTION FOR
B/BK/BS/BWT/C/CS/CWT/CK/CX-SERIES PLUNGER PUMPS
on GAS ENGINES with 1" SHAFTS
REQUIRES 11.5 OZ. 90W GEAR LUBE**

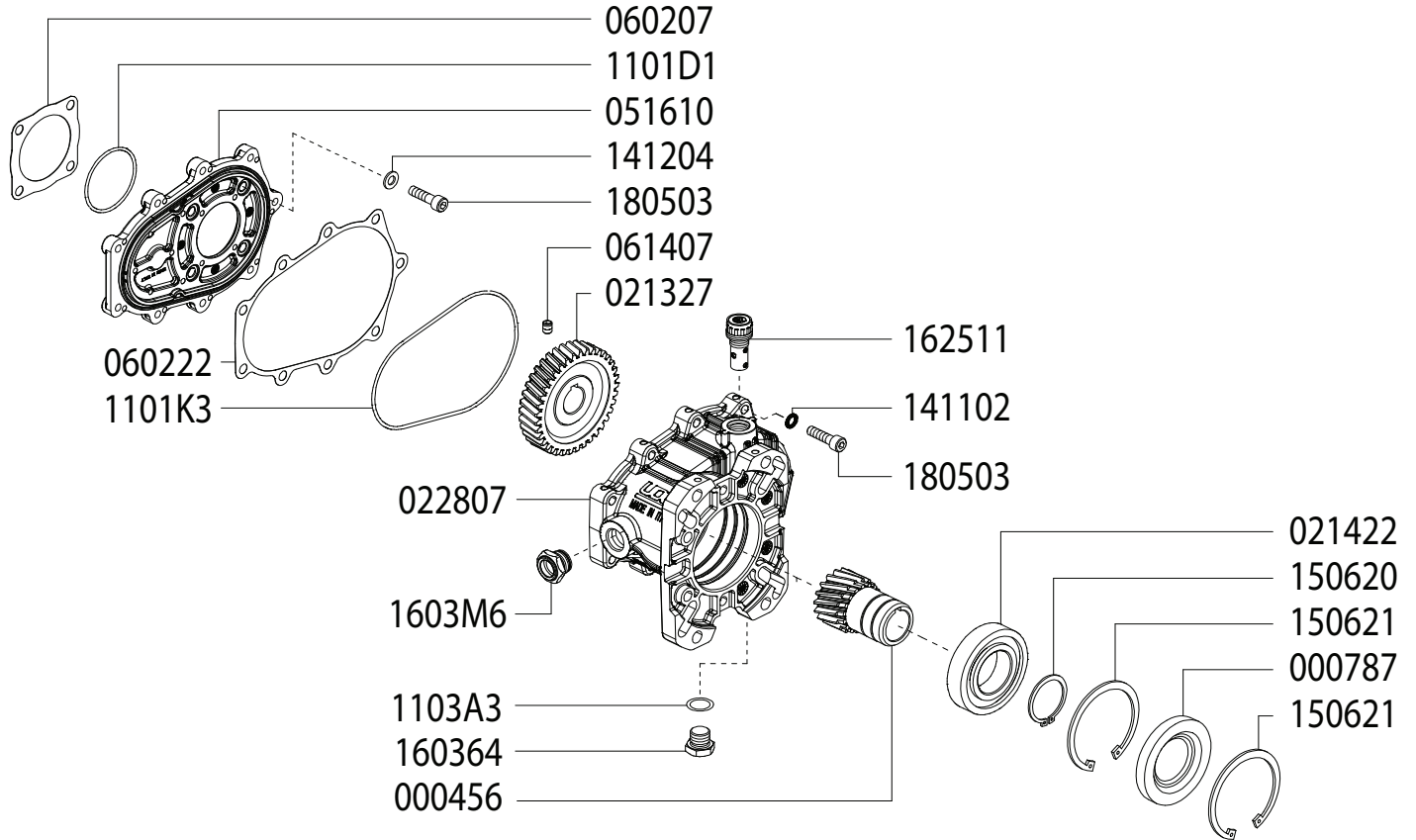

Updated 9-27-2024

Part #	Description	Qty	Part #	Description	Qty
0004.56	GEAR - 1"	1	1101.D1	O-RING	1
0007.87	OIL SEAL - D40 - RBC122K	1	1101.K3	O-RING	1
0213.27	PUMP GEAR	1	1411.02	WASHER	9
0214.22	BEARING - D40 - RBC122K	1	1412.04	WASHER	4
0228.07	COUPLER - RBC122	1	1506.20	SNAP RING - D40	1
0516.10	FLANGE - RBC122	1	1506.21	SNAP RING - D80	2
0602.07	GASKET - RC122	1	1603.64	PLUG - 3/8"	1
0602.22	GASKET - RBC122 HOUSING	1	1603.M6	OIL SIGHT GLASS	1
0614.07	SET SCREW - M5X8	1	1625.11	OIL PLUG - G3/8"	1
1101.A3	O-RING	1	1805.03	ALLEN BOLT - M8x30	13

**GAS ENGINE GEAR REDUCTION FOR
B/BK/BS/BWT/C/CS/CWT/CK/CX-SERIES PLUNGER PUMPS
on GAS ENGINES with 1-1/8" SHAFTS
REQUIRES 11.5 OZ. 90W GEAR LUBE**

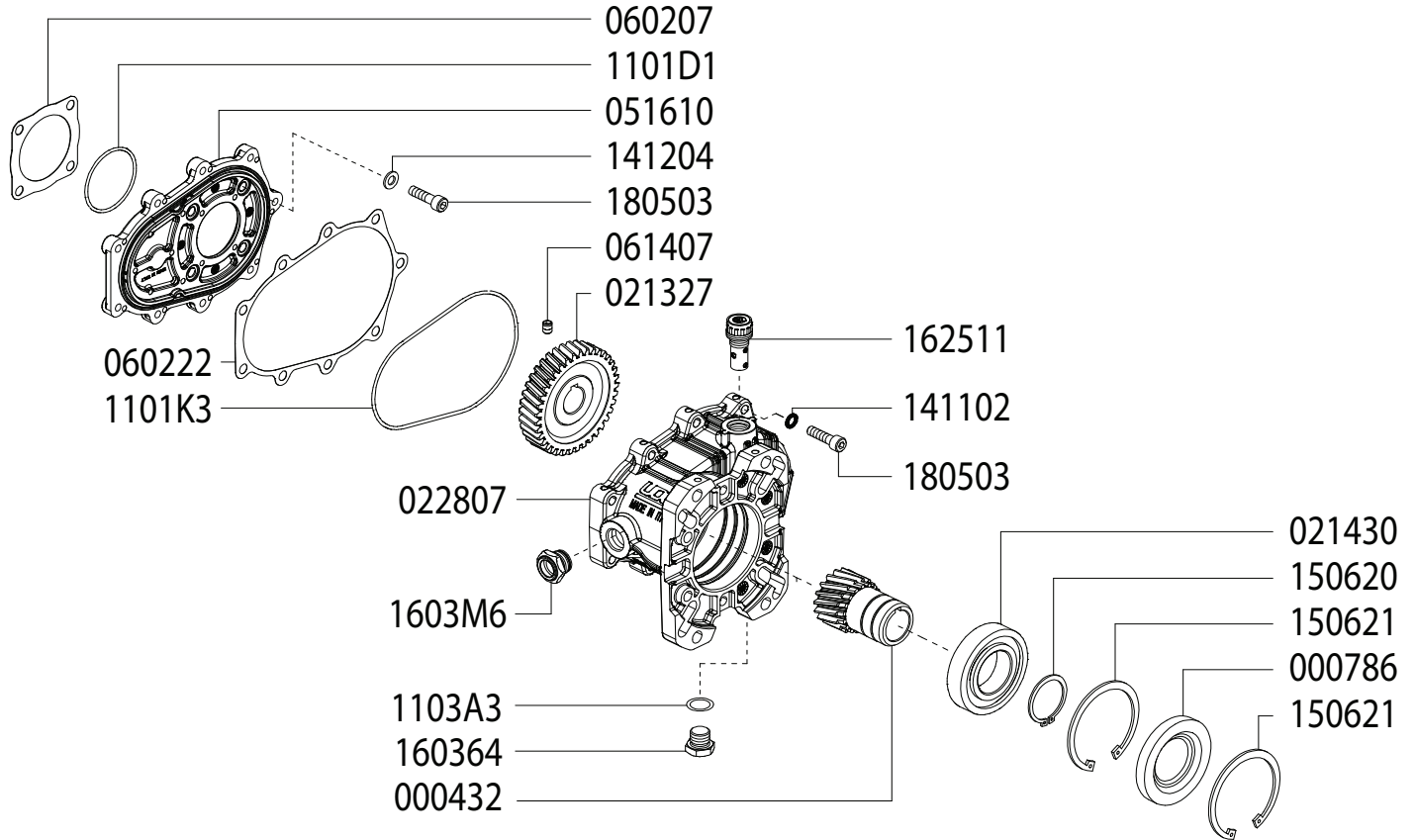

Updated 9-27-2024

Part #	Description	Qty	Part #	Description	Qty
0004.32	GEAR - 1-1/8"	1	1101.D1	O-RING	1
0007.87	OIL SEAL - D40 - RBC122X	1	1101.K3	O-RING	1
0213.27	PUMP GEAR	1	1411.02	WASHER	9
0214.30	BEARING - D40 - RBC122X	1	1412.04	WASHER	4
0228.07	COUPLER - RBC122	1	1506.20	SNAP RING - D40	1
0516.10	FLANGE - RBC122	1	1506.21	SNAP RING - D80	2
0602.07	GASKET - RC122	1	1603.64	PLUG - 3/8"	1
0602.22	GASKET - RBC122 HOUSING	1	1603.M6	OIL SIGHT GLASS	1
0614.07	SET SCREW - M5X8	1	1625.11	OIL PLUG - G3/8"	1
1101.A3	O-RING	1	1805.03	ALLEN BOLT - M8x30	13

*Dimensional Drawings are
Shown in Millimeters.
To Convert to Inches,
Multiply Dimension x 0.03937*

CK SERIES PUMPS BELOW 10 GPM

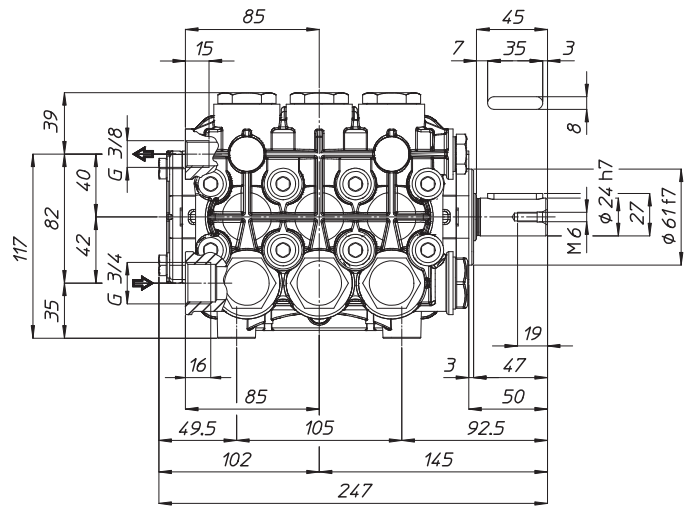
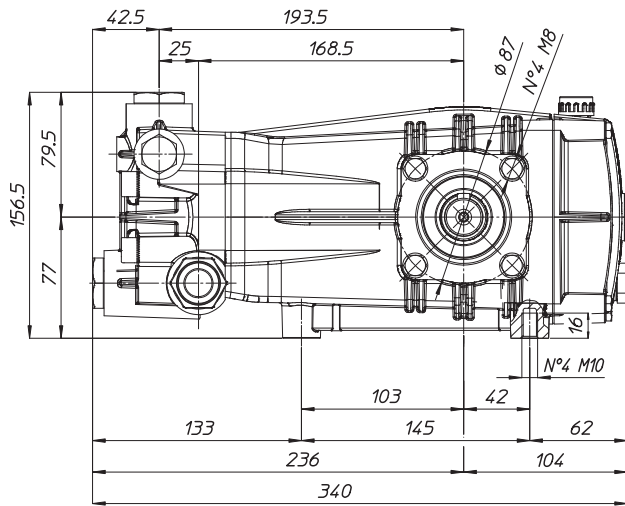

TORQUE SPECS

Ref.	Description	Ft./lb.	Nm	Loctite®
1	Head Bolts	37	50	-
2	Valve Caps	103	140	243
3	Inlet Cap	103	140	-
4	Outlet Cap	103	140	243
5	Bearing Flange Bolts	19	25	-
6	Rear Cover Bolts	8	11	-
7	Connecting Rod Bolts	19	25	270
8	Plunger Bolts	15	20	270
9	Valve Cover Bolts	-	-	-
10	Oil Drain Plug	8	11	-

