

- Solid Ceramic Plungers
- Stainless Steel Check Valves
- Stainless Steel Block Manifold with Nickel Plated Valve Covers
- Deeper Back Cover for Increased Oil Capacity
- 34.5 oz. Capacity Vented Oil Bath Crank Case
- 3/4" BSP-F Inlet. 3/8" BSP-F Outlet
- Max Fluid Temp, 160°F

CHC Series 24mm Keyed Solid Shaft Plunger Pumps

CHC Series super duty plunger pumps include a wide range of models with flow rates from 3.2 to 5.3 GPM and pressures up to 7250 PSI.

Other drive options include gas engine gear reduction.

Applications include general pressure cleaning,, construction, hydro-excavation and oil field applications.

	Model	Flow		Pressure		Plunger Dia.	Crankshaft		Power	Seal Kit	Valve Kit	Wt.
		GPM	l/min	PSI	bar		Stroke	Code				
1450 RPM	CHC 12/50 S	3.2	12.0	7250	500	15mm	17.0mm	X	15.4 EBHP	6061.88	6061.G1	49 lbs
	CHC 16/50 S	4.2	16.0	7250	500	15mm	22.0mm	1	20.5 EBHP	6061.88	6061.G1	49 lbs
	CHC 20/50 S	5.3	20.0	7250	500	18mm	19.0mm	Y	25.6 EBHP	6061.G2	6061.G1	49 lbs

NOTE: All pump models available with left-hand drive option. Add 'L' to model number when ordering (ex. CHD 4.5/75 SL)



MAX FLOW
MAX PRESSURE
RATED PUMP SPEED
POWER REQUIREMENT
LUBRICATION

3.2 GPM / 12.0 L/MIN
7250 PSI / 500 BAR
1450 RPM
15.4 HP ELECTRIC
34.5 OZ UDOR LUBE

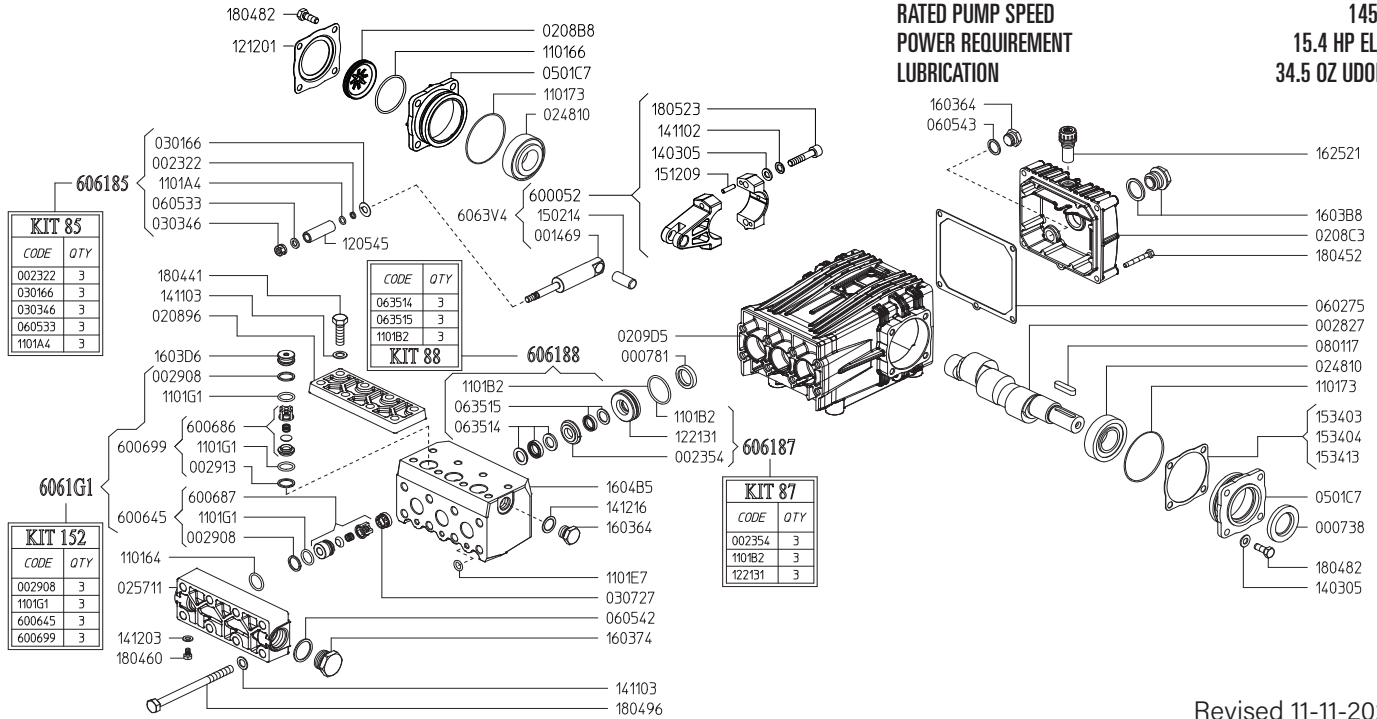

Revised 11-11-2024

Part #	Description	Qty	Part #	Description	Qty
0007.38	OIL SEAL D30	1	1221.31	PRESSURE RING D15 ^D	3
0007.81	OIL SEAL D20	3	1403.05	WASHER D8,4	10
0014.69	PLUNGER GUIDE D15 "CH"	3	1411.02	SERRATED WASHER D8	6
0023.22	RING D6.3 ^B	3	1411.03	SERRATED WASHER D10	16
0023.54	UPPER RING D15 ^D	3	1412.03	BONDED WASHER D6.7	1
0028.27	MALE SHAFT D24	1	1412.16	BONDED WASHER D17.3	1
0029.08	RING ^A	3	1502.14	PIN D14X32	3
0029.08	RING ^A / PART OF 6006.45	3	1512.09	PLUG D5X20 UNI1707	6
0029.13	RING ^A / PART OF 6006.99	3	1534.03	SHIM 0.1 MM	-
0208.96	COVER "CH"	1	1534.04	SHIM 0.2 MM	-
0208.B8	OIL SIGHT GLASS	1	1534.13	SHIM 0.05 MM	-
0208.C3	BACK COVER "C/CK"	1	1603.64	PLUG G3/8	2
0209.D5	GRANKCASE "C/CK/CH"	1	1603.74	PLUG G3/4	1
0248.10	ROLLER BEARING D30	2	1603.B8	OIL PLUG G3/4 + GASKET	1
0257.11	SUCTION MANIFOLD	1	1603.D6	PLUG	3
0301.66	SLINGER RING ^B	3	1604.B5	HEAD PISTON D15 SS	1
0303.46	NUT D15 ^B	3	1625.21	OIL PLUG G3/8	1
0307.27	SPACER	3	1804.09	HEX BOLT M8X40	6
0501.C7	BEARING HOLLOW FLANGE	2	1804.41	HEX BOLT M10X35	8
0602.75	BACK COVER GASKET	1	1804.52	HEX BOLT M6X45	5
0605.33	GASKET D8 ^B	3	1804.60	HEX BOLT M6X10	1
0605.42	GASKET D27	1	1804.82	HEX BOLT M8X22	8
0605.43	GASKET D17	1	1804.96	HEX BOLT M10X140	8
0635.14	HIGH PRESSURE SEAL KIT D15 ^C	3	6000.52	ROD ASSEMBLY	3
0635.15	LOW PRESSURE SEAL KIT D15 ^C	3	6006.45	SUCTION VALVE ASS'Y COMPLETE ^A	3
0801.17	KEY A8X7X35	1	6006.86	OUTLET VALVE ASS'Y W/O O-RING ^A / in 6006.99	3
1101.64	O-RING - SUCTION MANIFOLD	3	6006.87	SUCTION VALVE ASS'Y W/O O-RING ^A / in 6006.45	3
1101.66	O-RING - OIL SIGHT GLASS	1	6006.99	OUTLET VALVE ASS'Y COMPLETE ^A	3
1101.73	O-RING - BEARING FLANGE	2	6061.85	PLUNGER KIT D15 (KIT 85)	
1101.A4	O-RING - PLUNGER ^B	3	6061.87	BRASS RING KIT D15 (KIT 87)	
1101.B2	O-RING - PRESSURE RING ^{C D}	3	6061.88	WATER SEAL KIT (KIT 88)	
1101.E7	O-RING - SPLITT MANIFOLD	3	6061.G1	VALVE KIT D18 (KIT 152)	
1101.G1	O-RING - VALVE ^A	3			
1101.G1	O-RING - VALVE ^A / in 6006.99	3			
1101.G1	O-RING - VALVE ^A / in 6006.45	3			
1205.45	CERAMIC PLUNGER D15	3			
1212.01	RETAINER - OIL SIGHT GLASS	1			

^A Parts in 6061.G1 (Kit 152).
^B Parts in 6061.85 (Kit 85).
^C Parts in 6061.88 (Kit 88).
^D Parts in 6061.87 (Kit 87).

*Dimensional Drawings are
Shown in Millimeters.
To Convert to Inches,
Multiply Dimension x 0.03937*

CH SERIES PUMPS - 24mm SOLID SHAFT

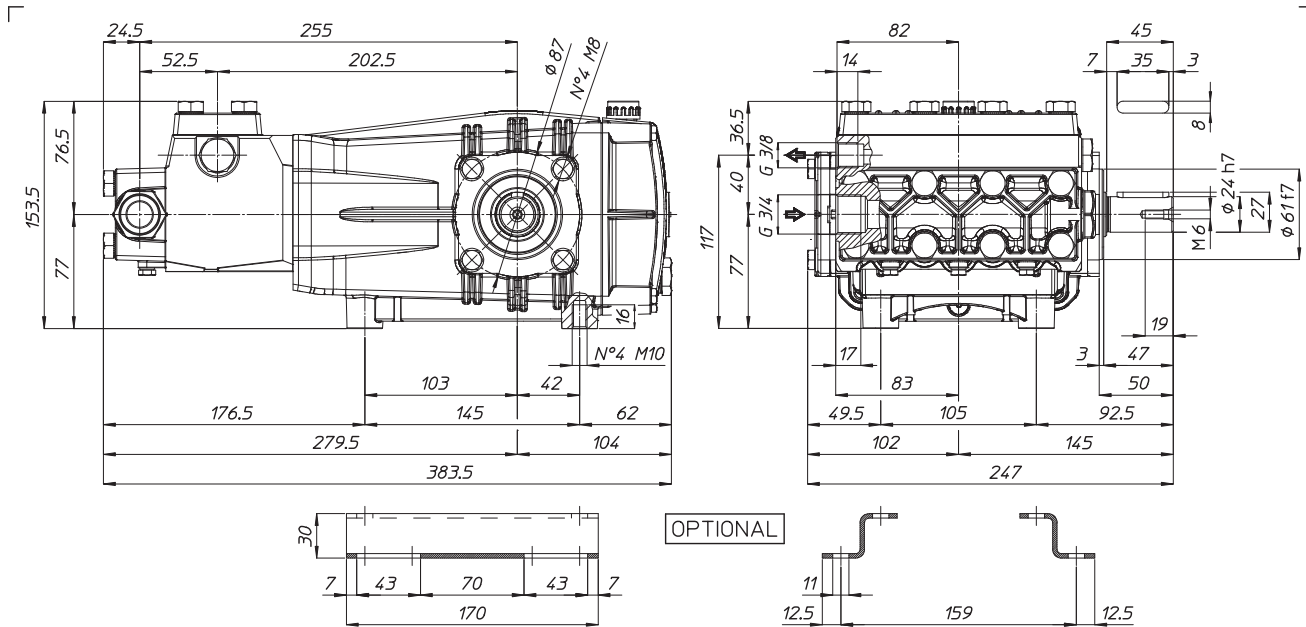

TORQUE SPECS

Ref.	Description	Ft./lb.	Nm	Loctite®
1	Head Bolts	37	50	-
2	Valve Caps	-	-	-
3	Inlet Cap	103	140	-
4	Outlet Cap	60	80	243
5	Bearing Flange Bolts	19	25	-
6	Rear Cover Bolts	8	11	-
7	Connecting Rod Bolts	19	25	270
8	Plunger Bolts	15	20	270
9	Valve Cover Bolts	37	50	-
10	Oil Drain Plug	8	11	-

