

## Gear Reduction, Gas Engine Models

1" or 1-1/8" Hollow Shaft, SAE J609-B Flange  
2.2:1 Gear Reduction Drive



- Solid Ceramic Plungers
- Stainless Steel Check Valves
- Heavy Duty Brass Manifold with External and Internal Bracing
- High Strength Aluminum Alloy Connecting Rods.
- Large Diameter Brass Valve Caps with Increased Thread Depth
- Reinforcing Ring on Inlet and Discharge Ports
- Deeper Back Cover for Increased Oil Capacity
- 34.5 oz. Capacity Vented Oil Bath Crank Case
- 3/4" BSP-F Inlet. 3/8" BSP-F Outlet: 5.5 - 8.5 GPM
- 3/4" BSP-F Inlet. 1/2" BSP-F Outlet: 9.0 GPM & Above
- Max Fluid Temp, 160°F
- Standard with 1" Hollow Shaft
- Available with 1-1/8" Hollow Shaft.  
Add '1-1/8' to Model Number to Specify when Ordering

### CC Series 24mm Keyed Solid Shaft Plunger Pumps

CC Series standard duty plunger pumps include a wide range of models with flow rates from 5.5 to 18.5 GPM and pressures up to 2900 PSI.

Other drive options include 24mm solid shaft and hydraulic motor flange.

Applications include general pressure cleaning, sewer jetting, vehicle wash equipment, street cleaning, construction, hydro-excavation and UHP fire fighting applications.

	Model	Flow		Pressure		Plunger Dia.	Crankshaft		Power	Seal Kit	Valve Kit	Wt.
		GPM	l/min	PSI	bar		Stroke	Code				
Gear Reduction	CC 21/20 GR	5.5	21.0	2900	200	22mm	13.5mm	N	14.5 HP Gas	6061.10	6061.03	36 lbs
	CC 26/20 GR	6.9	26.0	2900	200	22mm	17.0mm	X	16.0 HP Gas	6061.10	6061.03	36 lbs
	CC 30/20 GR	7.9	30.0	2900	200	25mm	15.0mm	V	20.0 HP Gas	6061.11	6061.03	36 lbs
	CC 34/20 GR	9.0	34.0	2900	200	25mm	17.0mm	X	23.0 HP Gas	6061.11	6061.03	36 lbs
	CC 38/17 GR	10.0	38.0	2465	170	28mm	15.0mm	V	20.0 HP Gas	6061.12	6061.03	36 lbs
	CC 42/17 GR	11.6	44.0	2465	170	28mm	17.0mm	X	23.0 HP Gas	6061.12	6061.03	36 lbs
	CC 50/15 GR	13.2	50.0	2175	150	28mm	19.0mm	Y	23.0 HP Gas	6061.12	6061.03	36 lbs
	CC 70/15 GR	18.5	70.0	2175	150	30mm	24.0mm	2	35.0 HP Gas	6072.02	6072.26	36 lbs

**NOTE:** All models available with 1" or 1-1/8" Hollow Shafts. Specify size when ordering (ex. **CC 21/20 GR1** or **CC 21/20 GR1-1/8.**)



MAX FLOW  
MAX PRESSURE  
RATED PUMP SPEED  
POWER REQUIREMENT  
LUBRICATION

7.9 GPM / 30.0 L/MIN  
2900 PSI / 200 BAR  
1450 RPM  
20.0 HP GAS  
34.5 OZ UDOR LUBE

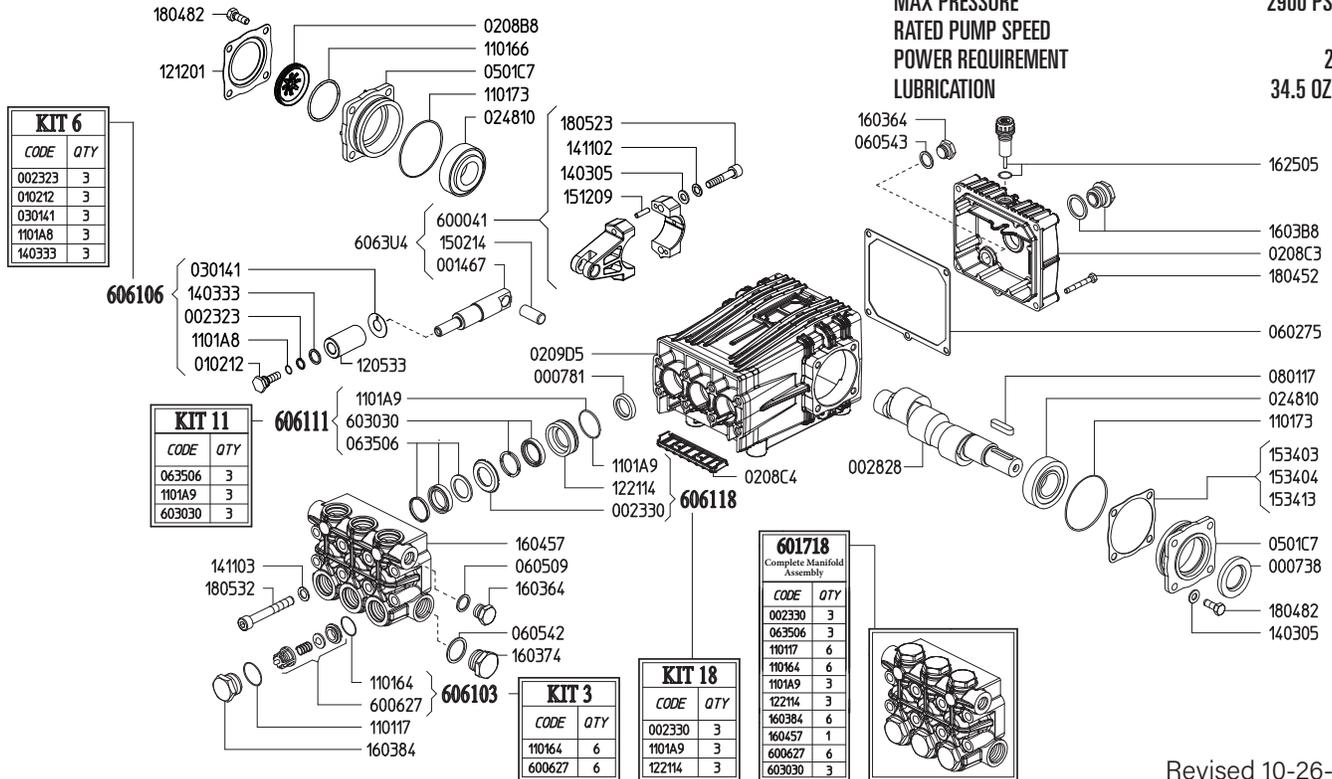

Revised 10-26-2023

Part #	Description	Qty	Part #	Description	Qty
0007.38	OIL SEAL D30	1	1403.33	WASHER D13.4 <sup>B</sup>	3
0007.81	OIL SEAL D20	3	1411.02	SERATED WASHER D8	6
0014.67	PLUNGER GUIDE D22/25/28 "C/CK"	3	1411.03	SERATED WAHSER D10	8
0023.23	RING D10.4 <sup>B</sup>	3	1502.14	PIN D14X32	3
0023.30	UPPER RING D25 <sup>D E</sup>	3	1512.09	PLUG D5X20 UNI1707	6
0028.28	MALE SHAFT D24	1	1534.03	SHIM 0.1 MM	1
0102.12	PLUNGER BOLT <sup>B</sup>	3	1534.04	SHIM 0.2 MM	1
0208.B8	OIL SIGHT GLASS	1	1534.13	SHIM 0.05 MM	1
0208.C3	BACK COVER "C/CK"	1	1603.64	PLUG G3/8	2
0208.C4	COVER "C/CK"	1	1603.74	PLUG G3/4	1
0209.D5	CRANKCASE "C/CK/CH"	1	1603.84	VALVE PLUG PISTON D22/25 <sup>E</sup>	6
0248.10	ROLLER BEARING D30	2	1603.B8	OIL PLUG G3/4" + GASKET	1
0301.41	SLINGER RING <sup>B</sup>	3	1604.57	HEAD "C/G" PISTON D22/25 <sup>E</sup>	1
0501.C7	BEARING HOLLOW FLANGE	2	1625.05	OIL PLUG G3/8	1
0602.75	BACK COVER GASKET	1	1804.52	HEX BOLT M6X45	5
0605.09	GASKET D17	1	1804.82	HEX BOLT M8X22	8
0605.42	GASKET D27	1	1805.23	ALLEN BOLT M8X40	6
0605.43	GASKET D17	1	1805.32	ALLEN BOLT M10X75	8
0635.06	HIGH PRESSURE SEAL KIT D25 <sup>C E</sup>	3	6000.41	ROD ASSEMBLY	3
0801.17	KEY A8X7X35	1	6006.27	VALVE ASSEMBLY W/O O-RING <sup>A E</sup>	6
1101.17	O-RING - VALVE PLUG <sup>E</sup>	6	6017.18	COMPLETE MANIFOLD ASSEMBLY	1
1101.64	O-RING - VALVE <sup>A E</sup>	6	6030.30	LOW PRESSURE SEAL KIT D25 <sup>C E</sup>	3
1101.66	O-RING - OIL SIGHT GLASS	1	6061.03	KIT 3 VALVE KIT	1
1101.73	O-RING - BEARING FLANGE	2	6061.06	KIT 6 PLUNGER KIT	1
1101.A8	O-RING - PLUNGER BOLT <sup>B</sup>	3	6061.11	KIT 11 WATER SEAL KIT D25 "C/CK"	1
1101.A9	O-RING - PRESSURE RING <sup>C D E</sup>	3	6061.18	KIT 18 BRASS RING KIT D25 "C/CK/CW"	1
1205.33	CERAMIC PLUNGER D25	3			
1212.01	RETAINER - OIL SIGHT GLASS	1			
1221.14	PRESSURE RING D25 <sup>D E</sup>	3			
1403.05	WASHER D8.4	10			

<sup>A</sup> Parts in 6061.03 (Kit 3).

<sup>B</sup> Parts in 6061.06 (Kit 6).

<sup>C</sup> Parts in 6061.11 (Kit 11).

<sup>D</sup> Parts in 6061.18 (Kit 18).

<sup>E</sup> Parts in 6017.18 (Complete Manifold Assembly).

**GAS ENGINE GEAR REDUCTION FOR  
B/BK/BS/BWT/C/CS/CWT/CK/CX-SERIES PLUNGER PUMPS  
on GAS ENGINES with 1" SHAFTS  
REQUIRES 11.5 OZ. 90W GEAR LUBE**

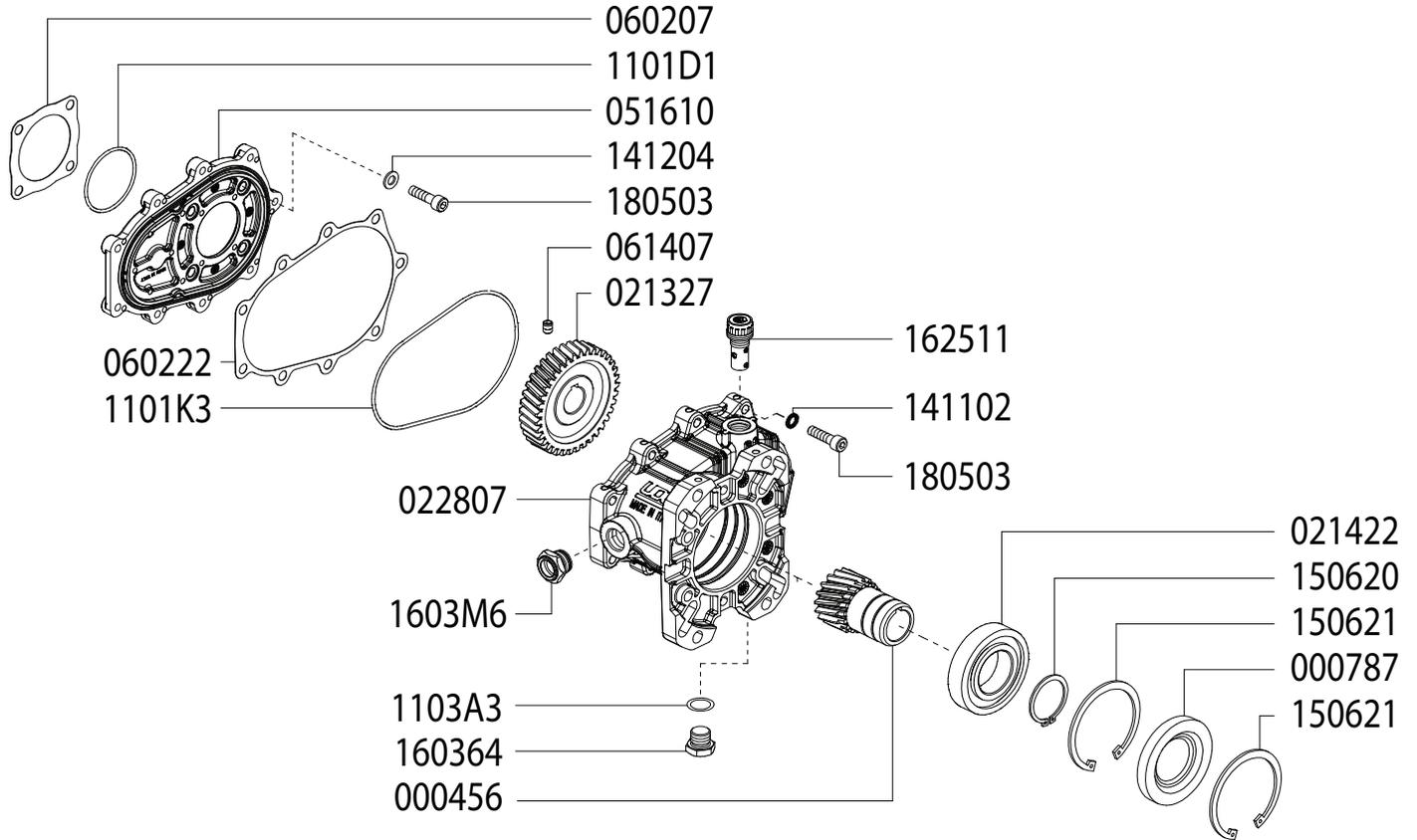

Updated 3-25-2024

Part #	Description	Qty	Part #	Description	Qty
0004.56	GEAR - 1"	1	1101.D1	O-RING	1
0007.87	OIL SEAL - D40 - RBC122K	1	1101.K3	O-RING	1
0213.27	PUMP GEAR	1	1411.02	WASHER	9
0214.22	BEARING - D40 - RBC122K	1	1412.04	WASHER	4
0228.07	COUPLER - RBC122	1	1506.20	SNAP RING - D40	1
0516.10	FLANGE - RBC122	1	1506.21	SNAP RING - D80	2
0602.07	GASKET - RC122	1	1603.64	PLUG - 3/8"	1
0602.22	GASKET - RBC122 HOUSING	1	1603.M6	OIL SIGHT GLASS	1
0614.07	SET SCREW - M5X8	1	1625.11	OIL PLUG - G3/8"	1
1101.A3	O-RING	1	1805.03	ALLEN BOLT - M8x30	13

**GAS ENGINE GEAR REDUCTION FOR  
B/BK/BS/BWT/C/CS/CWT/CK/CX-SERIES PLUNGER PUMPS  
on GAS ENGINES with 1-1/8" SHAFTS  
REQUIRES 11.5 OZ. 90W GEAR LUBE**

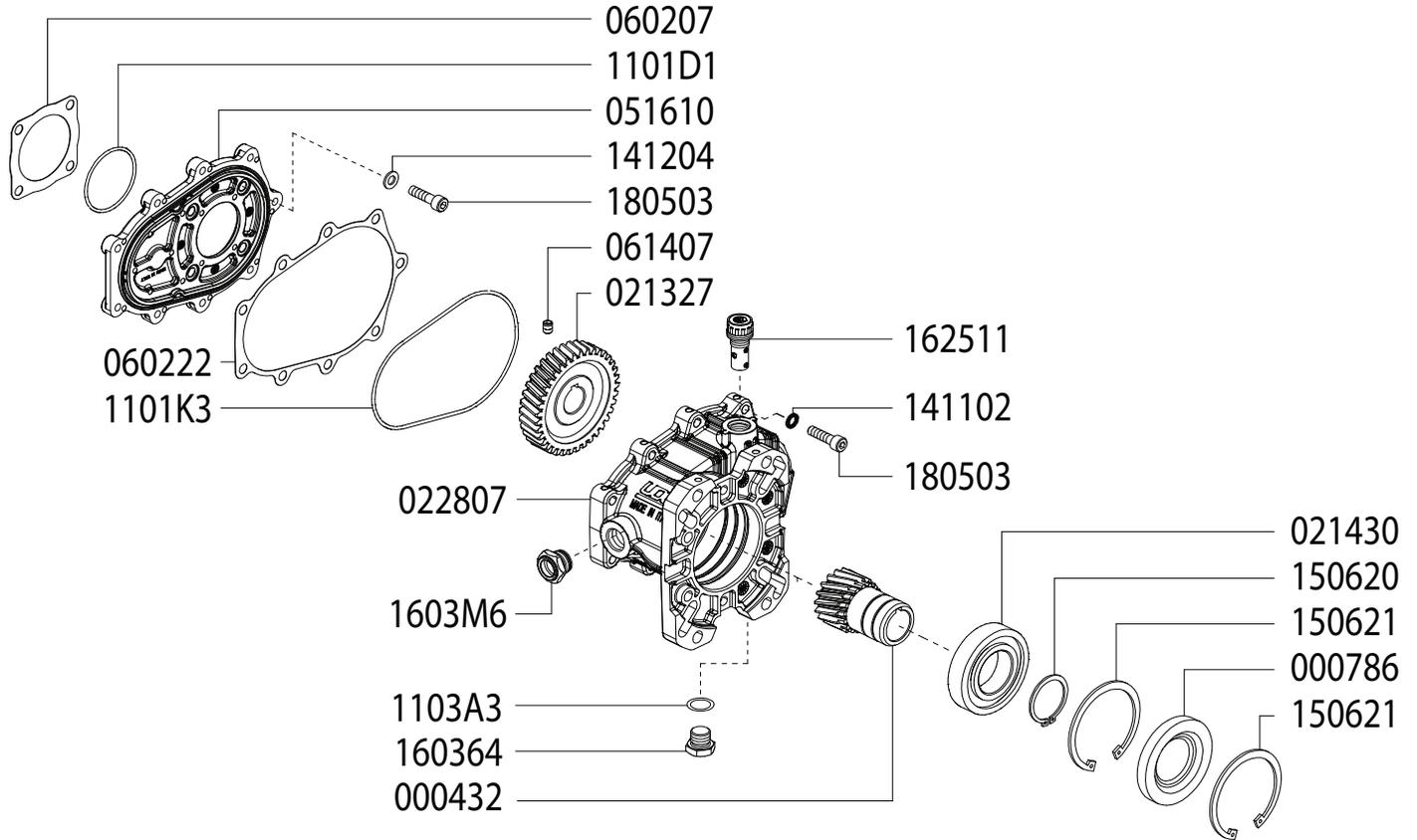

Updated 3-25-2024

Part #	Description	Qty	Part #	Description	Qty
0004.32	GEAR - 1-1/8"	1	1101.D1	O-RING	1
0007.87	OIL SEAL - D40 - RBC122X	1	1101.K3	O-RING	1
0213.27	PUMP GEAR	1	1411.02	WASHER	9
0214.30	BEARING - D40 - RBC122X	1	1412.04	WASHER	4
0228.07	COUPLER - RBC122	1	1506.20	SNAP RING - D40	1
0516.10	FLANGE - RBC122	1	1506.21	SNAP RING - D80	2
0602.07	GASKET - RC122	1	1603.64	PLUG - 3/8"	1
0602.22	GASKET - RBC122 HOUSING	1	1603.M6	OIL SIGHT GLASS	1
0614.07	SET SCREW - M5X8	1	1625.11	OIL PLUG - G3/8"	1
1101.A3	O-RING	1	1805.03	ALLEN BOLT - M8x30	13

WEIGHT  
LUBRICATION

36 LBS  
34.5 OZ UDOR LUBE

*Dimensional Drawings are  
Shown in Millimeters.  
To Convert to Inches,  
Multiply Dimension x 0.03937*

## C SERIES PUMPS BELOW 9 GPM

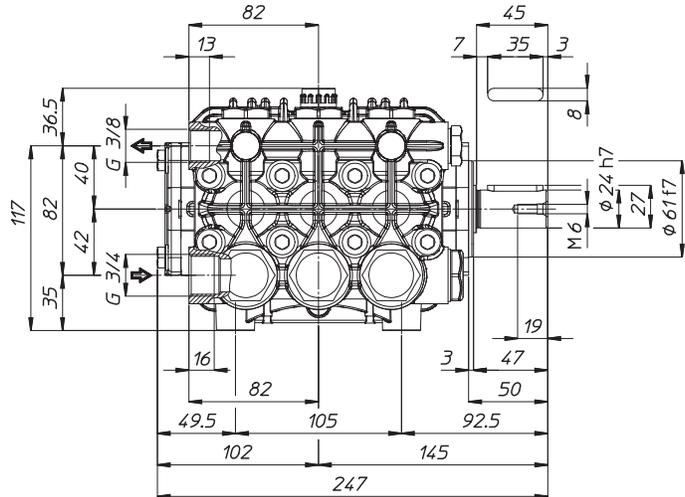
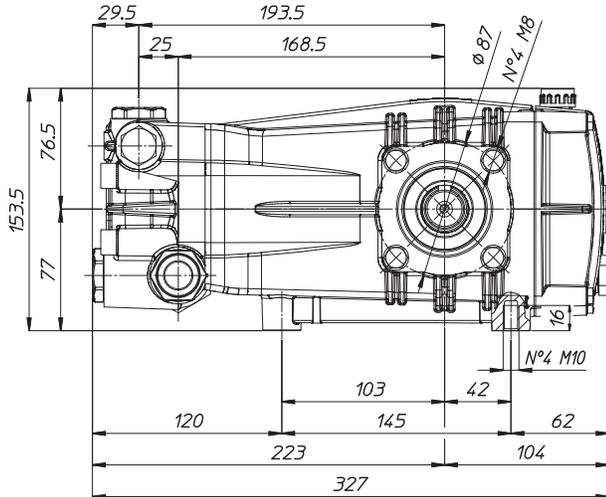

## TORQUE SPECS

Ref.	Description	Ft./lb.	Nm	Loctite®
1	Head Bolts	37	50	-
2	Valve Caps	103	140	243
3	Inlet Cap	103	140	-
4	Outlet Cap	103	140	243
5	Bearing Flange Bolts	19	25	-
6	Rear Cover Bolts	8	11	-
7	Connecting Rod Bolts	19	25	270
8	Plunger Bolts	15	20	270
9	Valve Cover Bolts	-	-	-
10	Oil Drain Plug	8	11	-

