

## 6-Cylinder, Low-Pressure Diaphragm Pumps

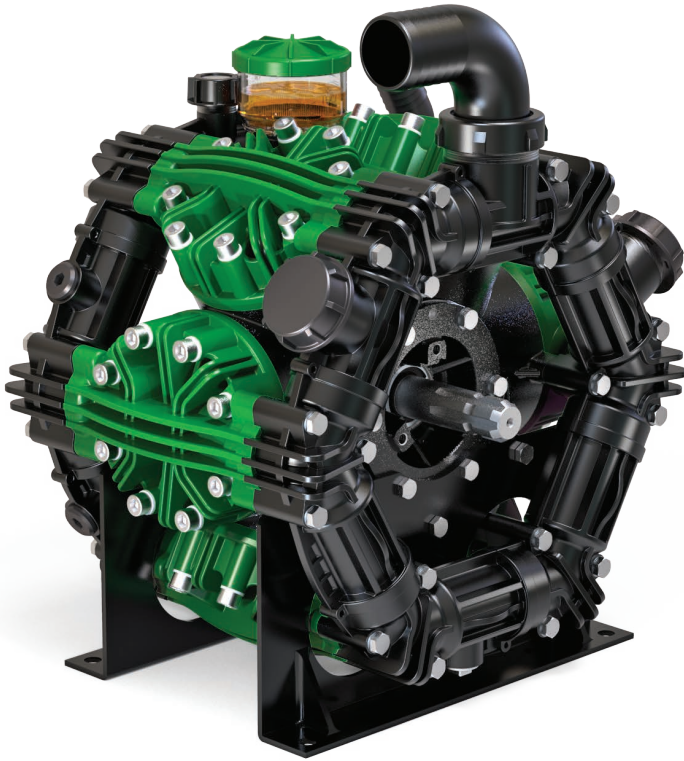

ZETA 400 low pressure 6-cylinder diaphragm pumps have anodized aluminum bodies with plasticized aluminum heads, stainless steel valves and glass-filled nylon manifolds.

ZETA 400 pumps are excellent for various horticultural and agricultural spraying applications.

Pumps are available with a 1-3/8" Male PTO thru-shaft.

Model	GPM	l/min	PSI	bar	RPM	Drive Configuration	Weight
ZETA 400 TS2C	106.0	400.0	300	20	550	1-3/8" 6-Spline Male PTO Thru-Shaft	155 LBS

Specifications	ZETA 400	Description	Part #
Inlet Port	2" & 2-1/2" Hose Barb	Diaphragm Kit (GREENTECH)	6062.G1
Outlet Ports - Valve	(2)1-1/2" Hose Barb	Diaphragm Bolt & Washer Kit	6062.G2
Piston Diameter	75.0mm	Valve Kit	6062.F9
Crankshaft Stroke/Code	18.0mm / E	Complete Repair Kit	8700.43CK
Dims. - Pump Only	20.5"L x 14.5"W x 23"H		

**Lubrication:** Requires 155 oz. of Udor Lube 40W Premium Pump Oil.  
Alternate Oil: 30W non-detergent or 15W-40 non-detergent oil.



Maximum Flow	106.0 GPM / 400 lpm
Maximum Pressure	300 PSI / 20 bar
Maximum RPM	550 RPM
Inlet Port - Hose Barb	2" & 2-1/2" HB
Outlet Port - Hose Barb	(2)1-1/2" HB
Bypass - Hose Barb	-
Dimensions	20.5"L x 14.5"W x 23"H
Weight	155 lbs

**Lubrication:** Requires 155 oz. of Udor Lube 40W Premium Pump Oil.  
 Alternate Oil: 30W non-detergent or 15W-40 non-detergent oil.

8700.43CK		6062F9		6062G1		6062G2	
CODE	QTY	KIT 660		KIT 661		KIT 662	
010217	6	1101E3	12	090362	6	010217	6
030176	6	6006A5	12	1101E3	12	030176	6
090362	6						
110142	1						
110193	4						
1101D2	2						
1101E3	12						
6006A5	12						

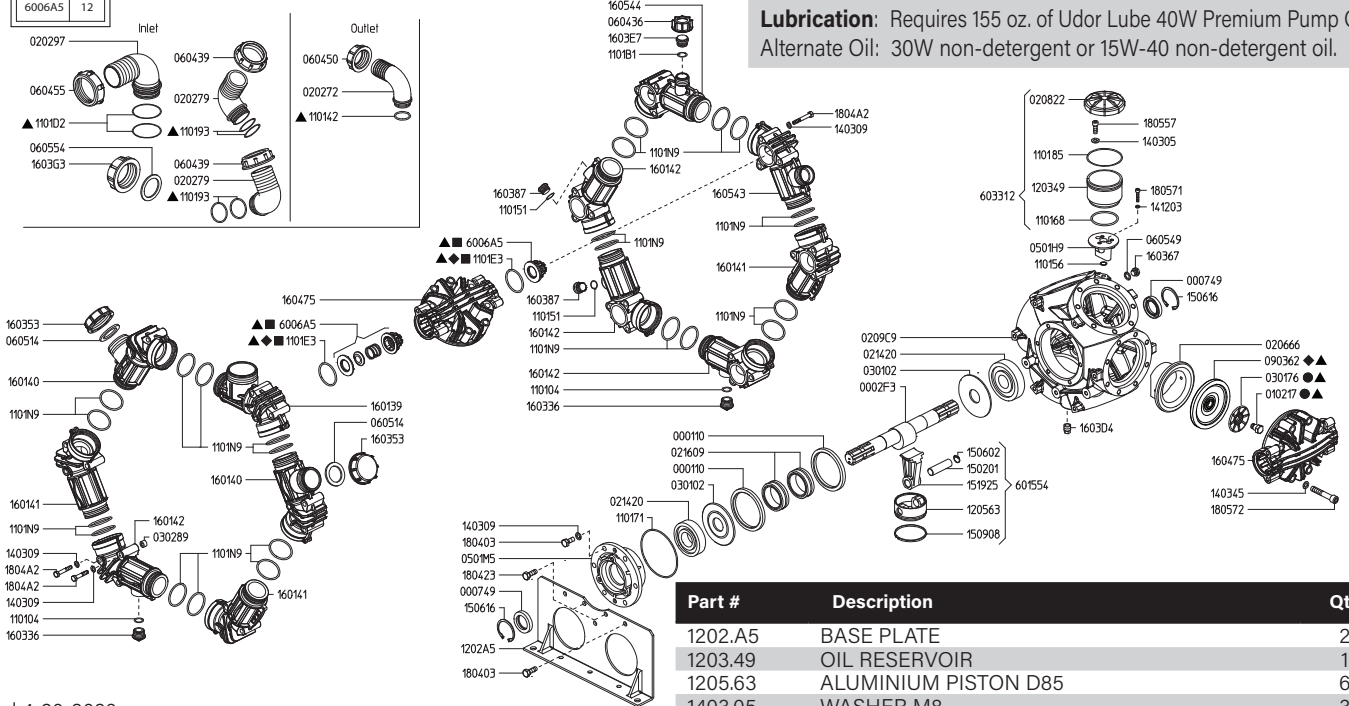

Revised 4-20-2026

Part #	Description	Qty
0001.10	RETAINER RING	2
0002.F3	CRANKSHAFT TS 2C	1
0007.49	OIL SEAL D35	2
0102.17	DIAPHRAGM BOLT ●▲	6
0202.72	DISCHARGE HOSE BARB D40	1
0202.79	INLET HOSE BARB D50	2
0202.97	INLET HOSE BARB D60	1
0206.58	SLEEVE D85	6
0208.22	OIL RESERVOIR CAP	1
0209.C9	CRANKCASE	1
0214.20	BALL BEARING D35	2
0216.09	ROLLER BEARING D55	2
0301.02	ROD DISC	2
0301.76	DIAPHRAGM WASHER ●▲	6
0302.89	SPACER	6
0501.H9	OIL CUP SUPPORT FLANGE	1
0501.M5	BEARING FLANGE	1
0604.36	BARB NUT G1"	1
0604.39	BARB NUT G2"	2
0604.50	BARB NUT G1-1/2"	1
0604.55	BARB NUT G2-1/2"	1
0605.14	GASKET D40	2
0605.49	GASKET D13	1
0605.54	GASKET D55	1
0903.62	PISTON DIAPHRAGM - GREENTECH 130MM ■▲	6
1101.04	O-RING - PLUG	2
1101.42	O-RING - OUTLET HOSE BARB ▲	1
1101.51	O-RING - PLUG	2
1101.56	O-RING - OIL RESERVIOR	1
1101.68	O-RING - OIL RESERVIOR	1
1101.71	O-RING - BEARING FLANGE	1
1101.85	O-RING - OIL RESERVIOR	1
1101.93	O-RING - INLET HOSE BARB ▲	4
1101.B1	O-RING - PLUG	1
1101.D2	O-RING - INLET HOSE BARB ▲	2
1101.E3	O-RING - VALVE ◆◆▲	12
1101.N9	O-RING - MANIFOLD TUBE	24

Part #	Description	Qty
1202.A5	BASE PLATE	2
1203.49	OIL RESERVOIR	1
1205.63	ALUMINIUM PISTON D85	6
1403.05	WASHER M8	3
1403.09	WASHER M10	42
1403.45	WASHER M13	48
1412.03	BONDED WASHER M6	2
1502.01	PIN D18X64	6
1506.02	SNAP RING D18	6
1506.16	SNAP RING D55	2
1509.08	PISTON RING D85	6
1519.25	CONNECTING ROD	6
1601.39	SUCTION MANIFOLD G2"1/2 M	1
1601.40	SUCTION MANIFOLD G2" M	2
1601.41	INLET-OUTLET MANIFOLD	3
1601.42	INLET-OUTLET MANIFOLD G3/4 F	4
1603.36	PLUG G3/4	2
1603.53	PLUG G2" F	2
1603.67	PLUG G1/4	1
1603.87	PLUG G3/4	2
1603.D4	PLUG G3/8	1
1603.E7	PLUG	1
1603.G3	PLUG G2"1/2 F	1
1604.75	HEAD	6
1605.43	OUTLET MANIFOLD G1"1/2 M	1
1605.44	OUTLET MANIFOLD G1" M	1
1804.03	HEX BOLT M10X30	10
1804.23	HEX BOLT M10X40	4
1804.A2	HEX BOLT M10X75	36
1805.57	ALLEN BOLT M8X22	3
1805.71	ALLEN BOLT M6X50	2
1805.72	ALLEN BOLT M12X75	48
6006.A5	VALVE ASSEMBLY W/O O-RING ■▲	12
6015.54	ROD ASSEMBLY - D85 PISTON	6
6033.12	OIL RESERVOIR ASSEMBLY	1
6062.F9	IN/OUTLET VALVE KIT (KIT 660)	1
6062.G1	DIAPHRAGM KIT - GREENTECH (KIT 661)	1
6062.G2	DIAPHRAGM BOLT & WASHER (KIT 662)	1
8700.43CK	COMPLETE REPAIR KIT	1

- Parts in 6062.F9 (Kit 660)
- ◆ Parts in 6062.G1 (Kit 661)
- Parts in 6062.G2 (Kit 662)
- ▲ Parts in 8700.43CK Repair Kit

# ZETA 350/400 DIMENSIONS

All Dimensions are WITHOUT Control Unit or Regulator

Dimensional Drawings are Shown in Millimeters. To Convert to Inches, Multiply Dimension x 0.03937

Specifications	ZETA 350	ZETA 400
Inlet Ports - Hose Barb	2" & 2-1/2" HB	2" & 2-1/2" HB
Outlet Ports - Hose Barb	(2)1-1/2" HB	(2)1-1/2" HB
Dimensions	20.5"L x 14.5"W x 23"H	
Diaphragm Material	GREENTECH (Std) Buna-N (Opt)	

**Lubrication:** Requires 39 oz. of Udor Lube 40W Premium Pump Oil. Alternate Oil: 30W non-detergent or 15W-40 non-detergent oil.

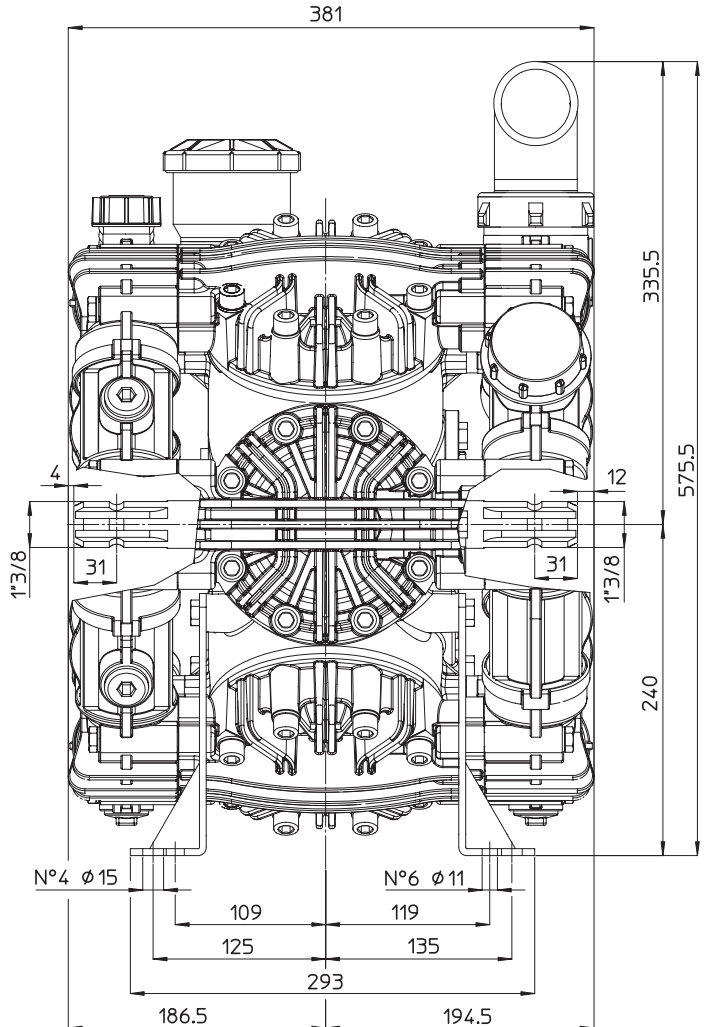
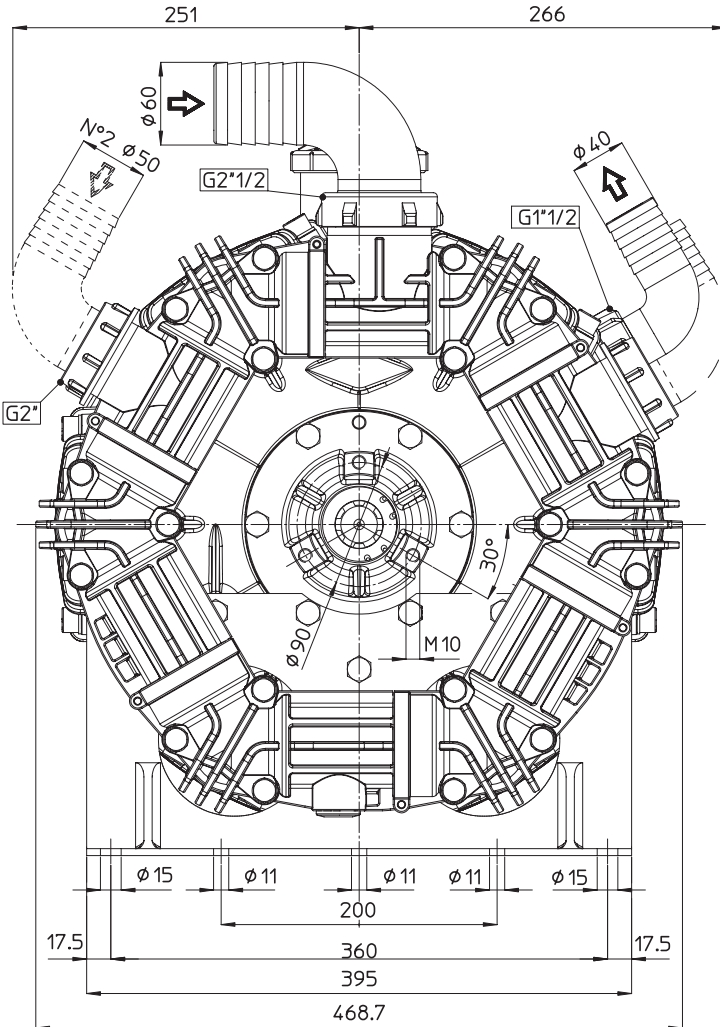

## TORQUE SPECS

Ref.	Description	Ft./lb.	Nm
1	Diaphragm Bolts (Use Loctite 243)	22	30
2	Head Bolts	30	40
3	Pulsation Dampener Bolts	-	-
4	Oil Cup Bolts	6	8
5	Manifold Bolts (Plastic)	14	20
NS	Bearing Flange Bolts (not shown)	25	34

