

3-Cylinder, Low-Pressure Diaphragm Pumps



ZETA-P 42 low pressure 3-cylinder diaphragm pumps have anodized aluminum bodies with plasticized aluminum heads, stainless steel valves and glass-filled nylon manifolds. A control valve with pressure gauge is standard on all models.

ZETA-P pumps are excellent for various horticultural and agricultural spraying applications.

Pumps are available with Universal VA Drive Face, hydraulic motor flange or gear reductions for 4 to 6.5 HP gas engines.

Model	GPM	l/min	PSI	bar	RPM	Drive Configuration	Weight
ZETA-P 42 VA	10.5	42	300	20	550	Universal VA Drive Face.	24.3 LBS
ZETA-P 42 VAGR3/4	10.5	42	300	20	550	Gear Reduction for 3/4" Shaft Gas Engine, 4-6.5 HP	31.3 LBS
ZETA-P 42 MI1	10.5	42	300	20	550	2-Bolt, A-Flange, 1" Hollow Shaft for Hydraulic Motor	24.3 LBS

Specifications	ZETA-P 42	Description	Part #
Inlet Port	1-1/4" Hose Barb	Diaphragm Kit - GREENTECH	
Outlet Ports - Valve	(2) 1/2" Hose Barb	Diaphragm Bolt & Washer Kit	
Bypass	3/4" Hose Barb	Valve Kit	
Piston Diameter	55.0mm	Regulator Repair Kit	
Crankshaft Stroke/Code		Complete Repair Kit	
Dims. - Pump Only	11"L x 11"W x 12"H		
- GR Version	16"L x 11"W x 12"H		

Lubrication: Requires 20 oz. of Udor Lube 40W Premium Pump Oil.
Alternate Oil: 30W non-detergent or 15W-40 non-detergent oil.



ZETA-P 42 VAGR3/4

Maximum Flow	10.5 GPM / 42.0 lpm
Maximum Pressure	300 PSI / 20 bar
Maximum RPM	550 RPM
Inlet Port - Hose Barb	1-1/4" HB
Outlet Ports - Hose Barb, Valve	(2) 1/2" HB
Bypass - Hose Barb	3/4" HB
Dimensions	11"L x 11"W x 12"H
Weight	24.3 lbs

Lubrication: Requires 20 oz. of Udor Lube 40W Premium Pump Oil.
Alternate Oil: 30W non-detergent or 15W-40 non-detergent oil.

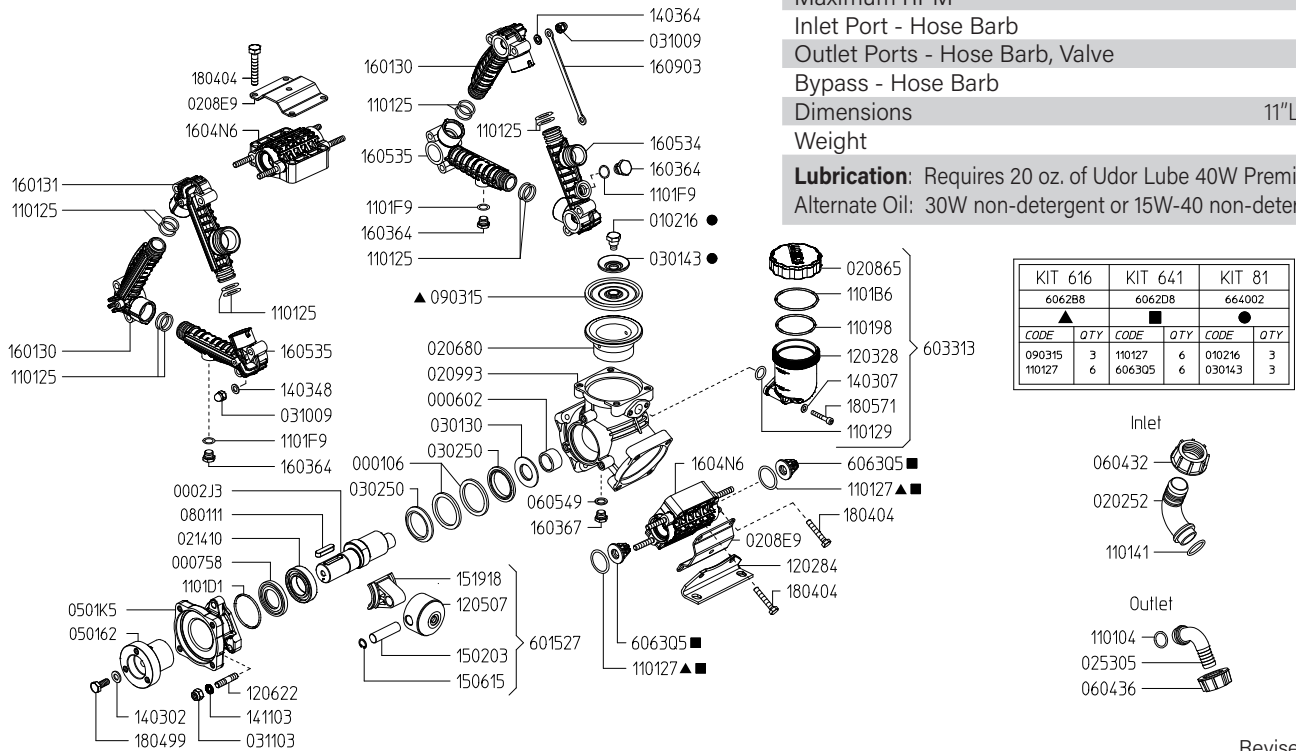

KIT 616		KIT 641		KIT 81	
6062B8	▲	6062D8	■	664002	●
CODE	QTY	CODE	QTY	CODE	QTY
090315	3	110127	6	010216	3
110127	6	606305	6	030143	3

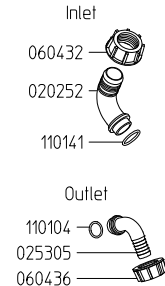

Revised 5-26-2026

Part #	Description	Qty	Part #	Description	Qty
0001.06	SPACER	2	1101.F9	O-RING - MANIFOLD PLUG	3
0002.J3	CRANKSHAFT - ZETA VA	1	1203.28	OIL RESERVOIR	1
0006.02	BUSHING	1	1205.07	ALUMINUM PISTON	3
0007.58	OIL SEAL	1	1206.22	STUD	3
0102.16	DIAPHRAGM BOLD ●	3	1208.84	MOUNTING RAIL	2
0202.52	HOSE BARB ELBOW - INLET	1	1403.02	WASHER	1
0206.80	SLEEVE	3	1403.07	WASHER	2
0208.65	CAP - OIL RESERVOIR	1	1403.48	WASHER	12
0208.E9	REINFORCING PLATE	3	1411.03	WASHER	3
0209.93	PUMP BODY	1	1502.03	PIN	3
0214.10	BEARING	1	1506.15	SNAP RING	3
0253.05	HOSE BARB ELBOW - BYPASS	1	1519.18	CONNECTING ROD	3
0301.30	SPACER	1	1601.30	MANIFOLD TUBE	2
0301.43	DIAPHRAGM WASHER ●	3	1601.31	MANIFOLD TUBE	1
0302.50	SEAL	2	1603.64	PLUG - MANIFOLD	3
0310.09	ACORN NUT	12	1603.64	MANIFOLD TUBE	1
0311.03	LOCK NUT	3	1603.67	PLUG	2
0501.62	FLANGE - VA	1	1604.N6	HEAD	3
0501.K5	BEARING FLANGE - VA	1	1605.35	MANIFOLD TUBEW/DRAIN	2
0604.32	NUT - INLET HOSE BARB	1	1609.03	MANIFOLD BRACE	3
0604.36	NUT - BYPASS HOSE BARB	1	1804.04	HEX BOLT	12
0605.49	GASKET	1	1804.99	HEX BOLT	1
0801.11	KEY	1	1805.71	ALLEN BOLT	2
0903.15	DIAPHRAGM 0 GREENTECH ▲	3	6015.27	CONNECTING ROD ASSY	3
1101.04	O-RING - BYPASS HOSE BARB	1	6033.13	OIL RESERVOIR ASSEMBLY	1
1101.07	O-RING - VALVE ▲ ■	6	6063.Q5	VALVE ASSY W/O O-RING ■	6
1101.25	O-RING - MANIFOLD TUBE	12	6062.B8	DIAPHRAGM KIT - GREENTECH (KIT 616)	1
1101.29	O-RING - OIL RESERVOIR	1	6062.D8	IN/OUTLET VALVE KIT (KIT 641)	1
1101.41	O-RING - INLET HOSE BARB	1	6640.02	DIAPHRAGM BOLT/WASHER KIT (KIT 81)	1
1101.98	O-RING - OIL RESERVOIR, INNER	1			
1101.B6	O-RING - OIL RESERVOIR, OUTER	1			
1101.D1	O-RING - BEARING FLANGE	1			

- ▲ Parts in 6062.B8 (Kit 616)
- Parts in 6062.D8 (Kit 641)
- Parts in 6640.02 (Kit 81)

**GAS ENGINE GEAR REDUCTION FOR
KAPPA-55, ZETA-40/85/120 DIAPHRAGM PUMPS
on GAS ENGINES with 3/4" SHAFTS
REQUIRES 16 OZ. 90W GEAR LUBE**

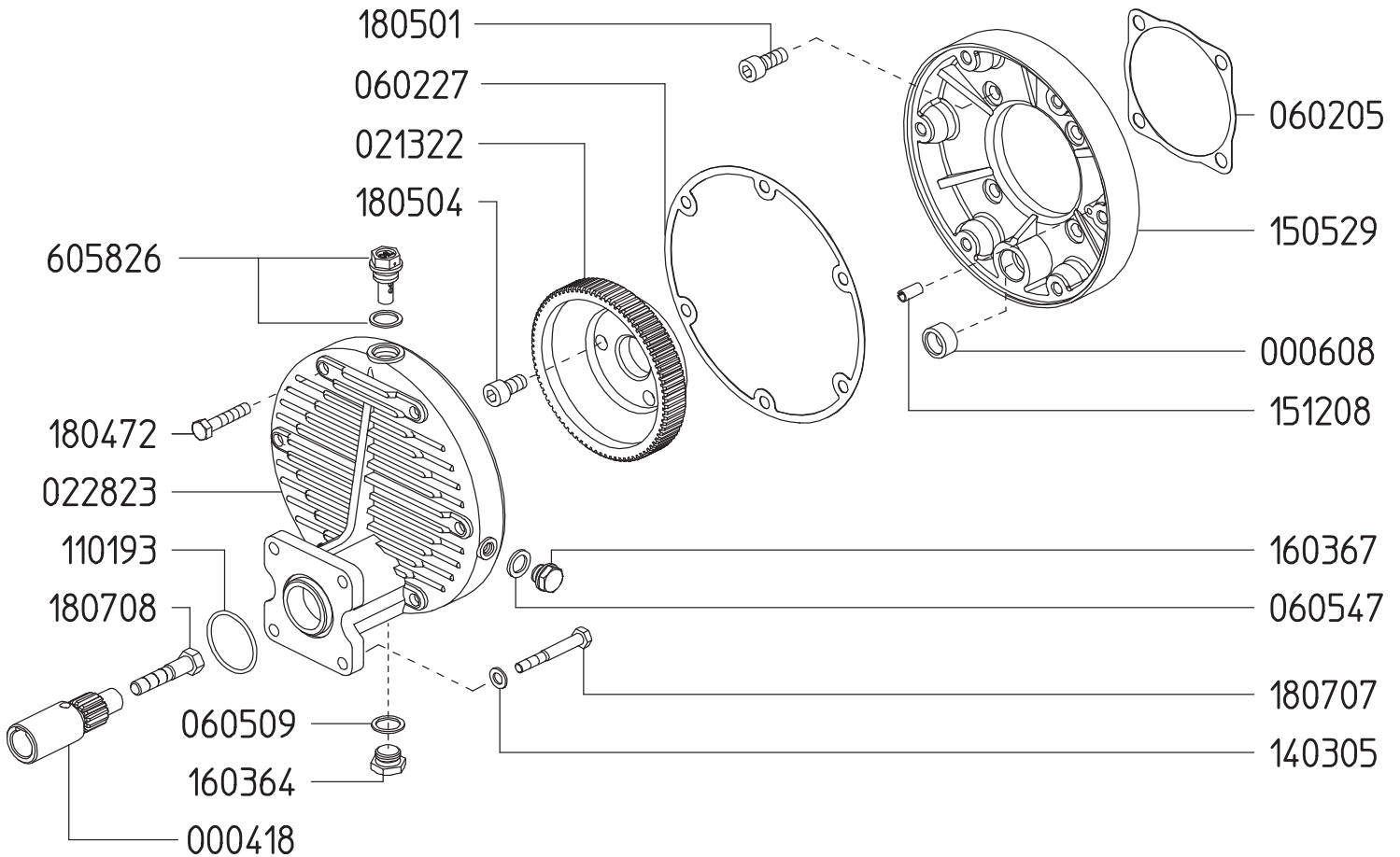

Revised 5-26-2026

Part #	Description	Qty	Part #	Description	Qty
0004.18	GEAR SHAFT - 3/4"	1	1505.29	GEAR CASE - PUMP	1
0006.08	BEARING	1	1512.08	ALIGNMENT PIN	1
0213.22	PUMP GEAR - VA	1	1603.64	OIL PLUG G3/8	1
0228.23	GEAR CASE - ENGINE	1	1603.67	OIL PLUG G1/4	1
0602.05	GASKET	1	1804.72	HEX BOLT M8X50	6
0602.27	GASKET	1	1805.01	ALLEN BOLT M10X25	4
0605.09	GASKET - ALUMINUM	1	1805.04	ALLEN BOLT M10X20	3
0605.47	GASKET - ALUMINUM	1	1807.07	HEX BOLT 5/16 X 1"	4
1101.93	O-RING	1	1807.08	HEX BOLT 5/16 X 2-1/4"	1
1403.05	WASHER	4	6058.26	VENTED OIL CAP	1

Adjustable Pressure Regulator

Maximum Flow	27.0 GPM / 102 lpm
Maximum Pressure	350 PSI / 24 bar
Inlet Port - Hose Barb	-
Outlet Ports - Hose Barb, Valve	(2) 1/2" HB
Bypass - Hose Barb	3/4" HB

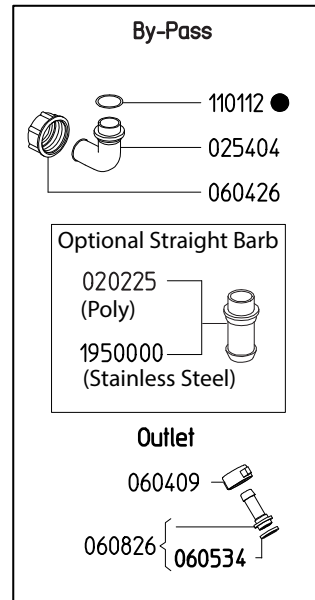
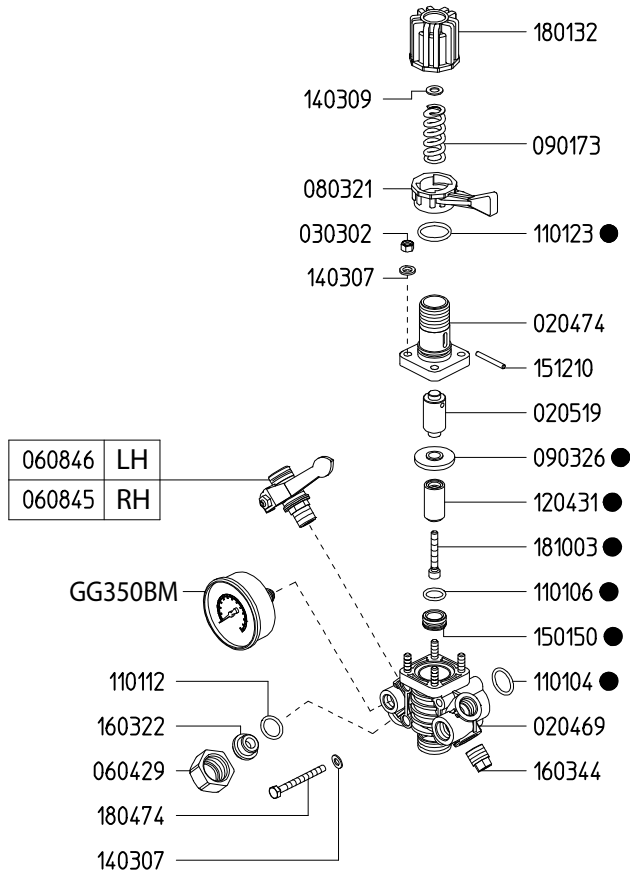

6062A9	
KIT 608	
CODE	QTY
090326	1
110104	1
110106	1
110112	1
110123	1
120431	1
150150	1
181003	1

Revised 9-25-2024

Part #	Description	Qty
0202.25	BYPASS HOSE BARB - STRAIGHT (OPTIONAL)	1
0204.69	BODY	1
0204.70	BODY	1
0205.19	CYLINDER	1
0254.04	BYPASS HOSE BARB - ELBOW	1
0303.02	NUT	4
0604.09	BARB NUT	2
0604.26	BYPASS BARB NUT	1
0604.29	NUT	1
0605.34	GASKET	2
0608.26	1/2" HOSE BARB W/GASKET	2
0608.45	BALL VALVE - RIGHT	1
0608.46	BALL VALVE - LEFT	1
0803.21	LEVER	1
0901.73	SPRING (LP 300 PSI)	1
0903.26	DIAPHRAGM ●	1
1101.04	O-RING ●	1

Part #	Description	Qty
1101.06	O-RING ●	1
1101.12	O-RING ●	2
1101.23	O-RING ●	1
1204.31	POPPET ●	1
1403.07	WASHER	6
1501.50	SEAT ●	1
1512.10	PIN	1
1603.22	PLUG	1
1603.44	PLUG	1
1801.32	ADJUSTMENT KNOB	1
1804.74	BOLT	2
1810.03	STAINLESS STEEL BOLT ●	1
19500.00	BYPASS HOSE BARB - STRAIGHT, SS (OPTIONAL)	1
6062.A9	REPAIR KIT FOR 6010.9X CONTROL UNIT (KIT 608)	1
GG350BM	PRESSURE GAUGE - 350 PSI BACK MOUNT	1

● Parts Included in Repair Kit #6062.A9 (KIT 608)

The control unit features a manual dump valve, pressure control knob, glycerine filled pressure gauge, and two ball valve discharge ports.

1. Before operating or re-operating the pump move lever (0803.21) to the dump position (Right) so the pump will start at zero pressure. (Failure to do so will void the pump warranty.)
2. Turn pressure adjustment knob (1801.32) counter clockwise to relieve spring tension. This step only applies to the initial start up and is not necessary in daily operation of pump.
3. Start unit and let run until air is evacuated from the system.
4. Move lever (0803.21) to the pressure position (Left) open spray gun or spray boom and turn the pressure adjustment knob (1801.32) clockwise until desired operating pressure is achieved.

All Dimensions are WITHOUT Control Unit or Regulator

Dimensional Drawings are Shown in Millimeters. To Convert to Inches, Multiply Dimension x 0.03937

Specifications

ZETA-P 42

Inlet Port - Hose Barb	1-1/4" HB
Outlet Port - Hose Barb	3/4" HB
Dimensions	11"L x 11"W x 12"H
Diaphragm Material	GREENTECH (Std) Buna-N (Opt)

Lubrication: Requires 20 oz. of Udor Lube 40W Premium Pump Oil.
Alternate Oil: 30W non-detergent or 15W-40 non-detergent oil.

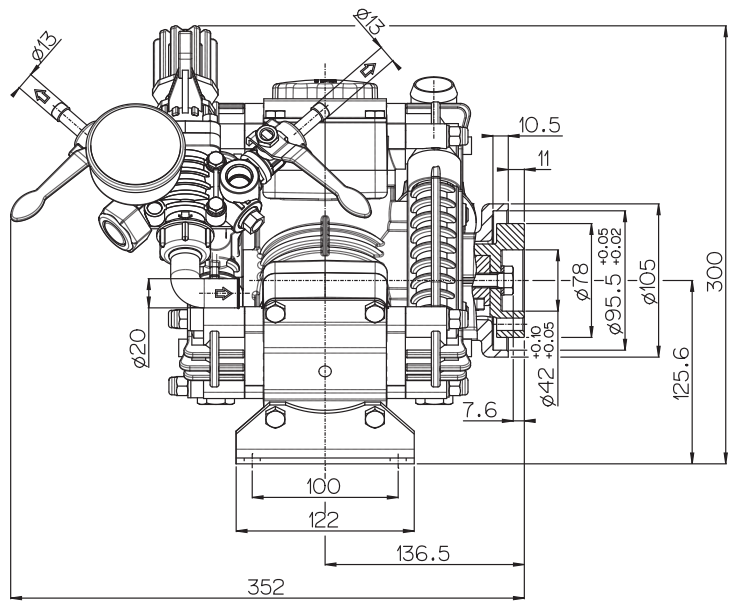
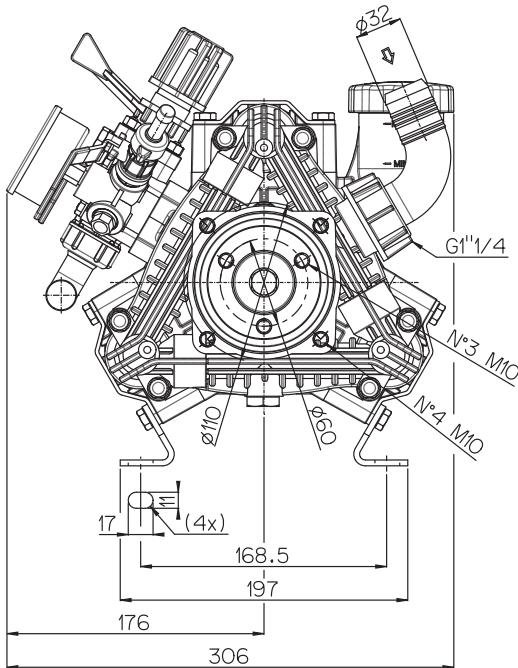

TORQUE SPECS

Ref.	Description	Ft./lb.	Nm
1	Diaphragm Bolts (Use Loctite 243)	18	25
2	Head Bolts	18	25
3	Pulsation Dampener Bolts	18	25
4	Oil Cup Bolts	6	8
5	Manifold Bolts (Plastic)	7	10

