

- Anodized Aluminum Crank Case
- Nickel-Plated Manifold
- Stainless Steel Check Valves
- Heavy Duty Bronze Connecting Rods
- Heavy Duty Roller Bearings
- 1-1/2" BSP-F Inlet. 1" BSP-F Outlet
- 128 oz. Oil Capacity
- Max Fluid Temp, 160°F

### VXX Series Plunger Pumps

VXX Series industrial duty plunger pumps are rated at 19.8 to 63.2 GPM and pressures up to 5075 PSI.

Pumps are available in 1000 or 1200 RPM models with a 40mm solid, keyed shaft.

Applications include sewer jetting, street cleaning and oil field equipment.

	Model	Flow		Pressure		Plunger Dia.	Crankshaft		Power	Seal Kit	Valve Kit	Wt.
		GPM	l/min	PSI	bar		Stroke	Code				
1000 RPM	VXX-B 75/350 R	19.8	75.0	5075	350	28mm	42.0mm	8	63.3 EBHP	6061.N2	6061.N3	141 lbs
	VXX-B 130/220 R	34.4	130.0	3190	220	36mm	42.0mm	8	73.3 EBHP	6061.F1	6061.E9	137 lbs
	VXX-B 160/180 R	42.3	160.0	2610	180	40mm	42.0mm	8	73.8 EBHP	6061.F3	6061.E9	137 lbs
	VXX-B 200/150 R	52.8	200.0	2175	150	45mm	42.0mm	8	76.9 EBHP	6061.F8	6061.E9	137 lbs
1200 RPM	VXX-F 240/140 R	63.2	239.0	2030	140	45mm	42.0mm	8	85.8 EBHP	6061.F8	6061.E9	137 lbs

NOTE: All pump models available with left-hand drive option. Substitute 'L' for 'R' in model number when ordering (ex. VXX-B 200/150 L)



**MAX FLOW**  
**MAX PRESSURE**  
**RATED PUMP SPEED**  
**POWER REQUIREMENT**  
**LUBRICATION**

**52.8 GPM / 200 L/MIN**  
**2175 PSI / 150 BAR**  
**1000 RPM**  
**76.9 HP ELECTRIC**  
**128 OZ UDOR LUBE**

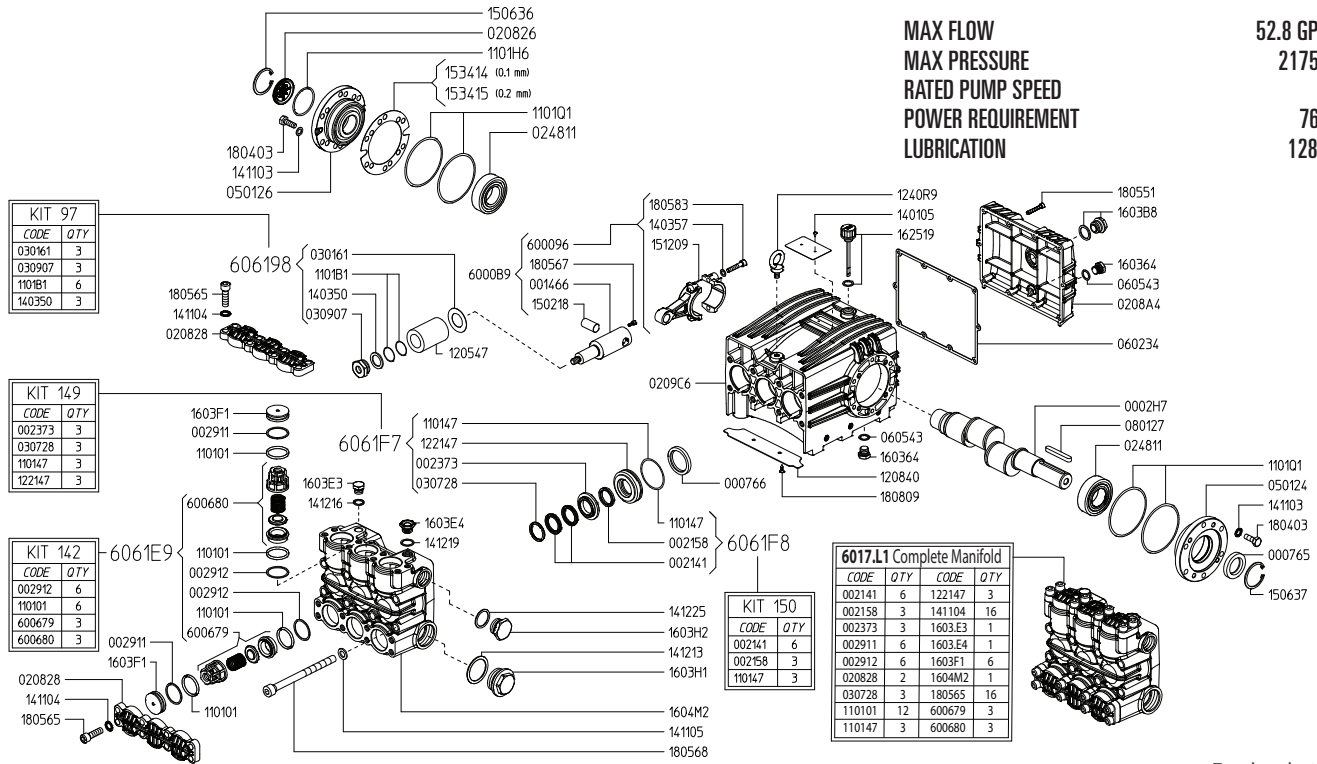

Revised 12-5-2023

Part #	Description	Qty
0002.H7	SHAFT "VXX"	1
0007.65	OIL SEAL D45	1
0007.66	OIL SEAL D42	3
0014.66	PLUNGER GUIDE ROD D45 "VXX"	3
0021.41	WATER SEAL H.P. D45 <sup>C E</sup>	6
0021.58	WATER SEAL L.P. D45 BPT <sup>C E</sup>	3
0023.73	UPPER RING D45 "VX" <sup>D E</sup>	3
0029.11	PLUG RING "VX" <sup>E</sup>	6
0029.12	RING "VX" <sup>B E</sup>	6
0105.02	BUSHING "VXX"	3
0208.26	OIL SIGHT GLASS	1
0208.A4	BACK COVER	1
0208.28	COVER "VXX" <sup>E</sup>	2
0209.C6	CRANKCASE "VXX"	1
0248.11	ROLLER BEARING D45	2
0301.61	DISC "VX" D45 SS <sup>A</sup>	3
0307.28	SPACER D45 "VX" <sup>D E</sup>	3
0309.07	NUT "VX" D45 <sup>A</sup>	3
0501.24	BEARING FLANGE - SHAFT SIDE	2
0501.26	BEARING FLANGE - OIL SIGHT GLASS SIDE	2
0602.34	BACK COVER GASKET "GAMMA 3P/VX"	1
0605.43	GASKET D17	2
0801.27	KEY A12X8X70	1
1101.01	O-RING - VALVE CAP <sup>E</sup>	6
1101.01	O-RING - VALVE <sup>B E</sup>	6
1101.47	O-RING - PRESSURE RING <sup>C D E</sup>	3
1101.B1	O-RING - PLUNGER BOLT <sup>A</sup>	6
1101.H6	O-RING - OIL SIGHT GLASS	1
1101.Q1	O-RING - BEARING FLANGE	4
1205.47	CERAMIC PLUNGER D45 "NX/VX"	3
1208.40	PLATE "VX"	1
1221.47	PRESSURE RING D45 "VX" <sup>D E</sup>	3
1240.R9	LIFTING HOOK M10	1
1401.05	RIVET UNI7346-3.5X8	2
1401.06	RIVET D4X10	2
1403.50	WASHER D25.2 <sup>A</sup>	3
1403.57	WASHER D8.4	6
1411.03	SERRATED WASHER D10	12
1411.04	SERRATED WASHER D12 <sup>E</sup>	16
1411.05	SERRATED WASHER D14	8

Part #	Description	Qty
1412.13	BONDED WASHER D48.4	1
1412.16	BONDED WASHER D17.3	1
1412.19	BONDED WASHER D21.5	1
1412.25	BONDED WASHER D33.9 (G1")	1
1502.18	PIN D20X34	3
1506.36	SNAP RING D55	1
1506.37	SNAP RING D60	1
1512.09	PLUG D5X20	6
1534.14	SHIM - 0.1MM	1
1534.15	SHIM - 0.2MM	1
1603.64	PLUG G3/8	2
1603.B8	OIL PLUG G3/4 + GASKET	1
1603.E3	PLUG G3/8 SS <sup>E</sup>	1
1603.E4	PLUG G1/2 SS <sup>E</sup>	1
1603.F1	VALVE PLUG "VX" <sup>E</sup>	6
1603.H1	PLUG G1-1/2" SS	1
1603.H2	PLUG G1" SS	1
1604.M2	HEAD "VXX" PISTON D45 <sup>E</sup>	1
1625.06	OIL PLUG G1/2 "VX/GAMMA-IL 3P"	1
1804.03	HEX BOLT M10X30	12
1805.23	ALLEN BOLT M8X40	6
1805.51	ALLEN BOLT M6X40	10
1805.65	ALLEN BOLT M12X40 <sup>E</sup>	16
1805.67	ALLEN BOLT M5X12	3
1805.68	ALLEN BOLT M14X130	8
1808.09	SELF-THREADING SCREW D5,5X13	2
6000.96	ROD ASSY "VX/VH/VY" BRONZE	3
6000.B9	COMPLETE ROD ASSEMBLY	3
6006.79	SUCTION VALVE ASSY "VX" W/O O-RING <sup>B E</sup>	3
6006.80	OUTLET VALVE ASSY "VX" W/O O-RING <sup>B E</sup>	3
6017.L1	COMPLETE MANIFOLD ASSEMBLY VXX D45	1
6061.98	PLUNGER KIT "VX" (KIT 97)	1
6061.E9	VALVE KIT "VX" (KIT 142)	1
6061.F7	BRASS RING KIT D40 "VX" (KIT 150)	1
6061.F8	WATER SEAL KIT D40 "VX" (KIT 149)	1

<sup>A</sup> Parts in 6061.98 (Kit 97).

<sup>B</sup> Parts in 6061.E9 (Kit 142).

<sup>C</sup> Parts in 6061.F8 (Kit 150).

<sup>D</sup> Parts in 6061.F7 (Kit 149)

<sup>E</sup> Parts in 6017.L1 (Complete Manifold).

*Dimensional Drawings are  
Shown in Millimeters.  
To Convert to Inches,  
Multiply Dimension x 0.03937*

## VXX SERIES PUMPS - 40mm SOLID SHAFT

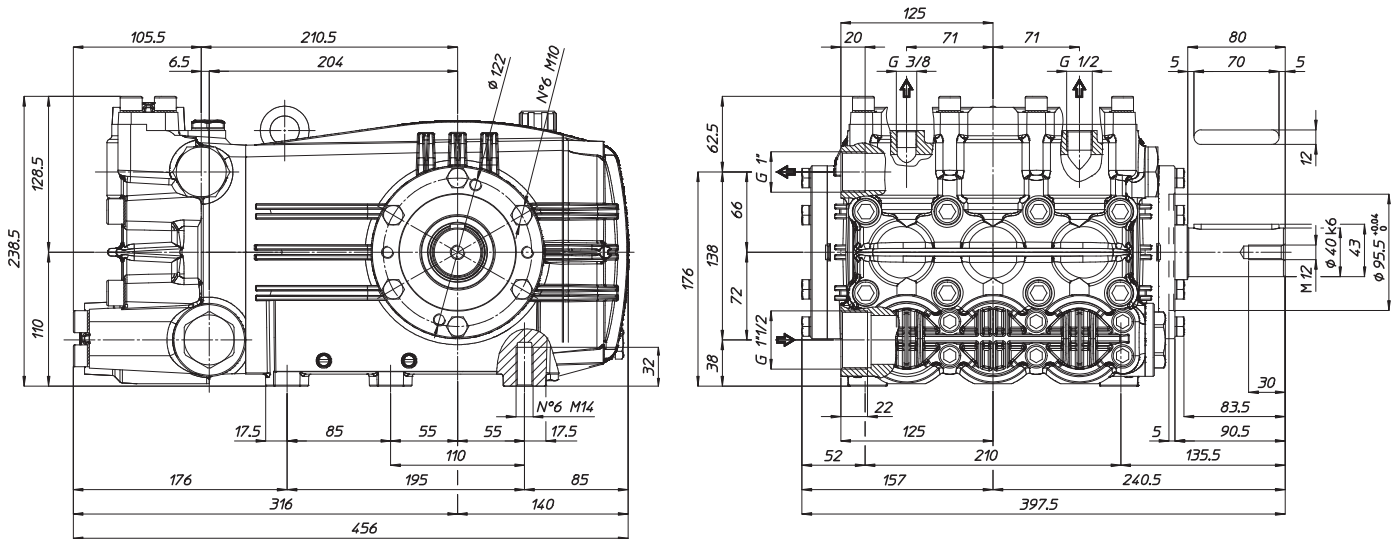

## TORQUE SPECS

Ref.	Description	Ft./lb.	Nm	Loctite®
1	Head Bolts	103	140	-
2	Valve Caps	-	-	-
3	Inlet Cap	147	200	-
4	Outlet Cap	133	180	243
5	Bearing Flange Bolts	30	57	-
6	Rear Cover Bolts	8	11	-
7	Connecting Rod Bolts	19	25	243
8	Plunger Bolts	30	40	243
9	Valve Cover Bolts	66	90	-
10	Oil Drain Plug	8	11	-

