



Stainless Steel



VXS-B SERIES

Solid Shaft Models

24mm Keyed Solid Shaft

1000 RPM

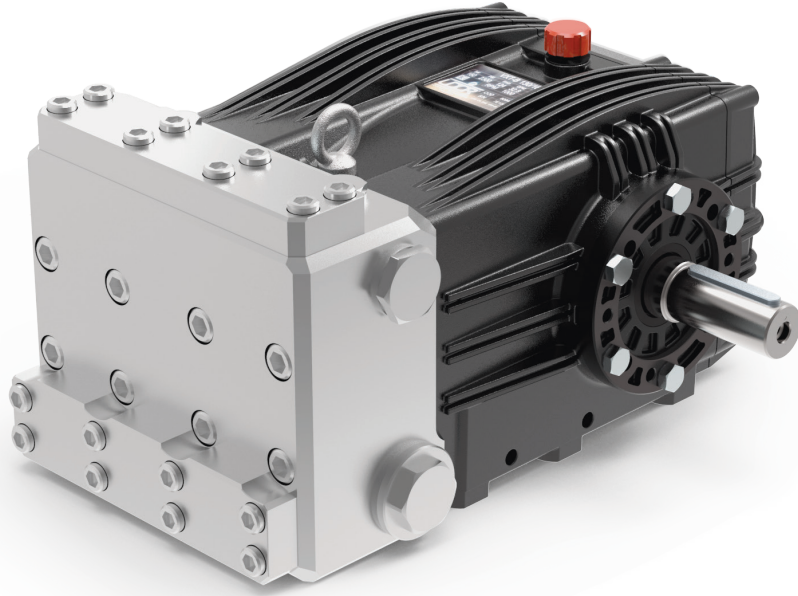

- 316 Stainless Steel Manifolds
- 316 Stainless Steel Valves
- 316 Stainless Steel Plunger Rods & Nuts
- 304 Stainless Steel Exterior Bolts
- Solid Ceramic Plungers
- 128 oz. Capacity Vented Oil Bath Crank Case
- 1-1/2" BSP-F Inlet. 1" BSP-F Outlet
- Max Fluid Temp, 160°F

VXS-B Series 24mm Keyed Solid Shaft Plunger Pumps

VXS-B Series stainless steel plunger pumps include a wide range of models with flow rates from 25.9 to 41.0 GPM and pressures up to 2900 PSI.

These pumps feature stainless steel wetted and exterior components to withstand the harsh environment of salt water applications.

VXS-B Series pumps are well suited for de-salination, disinfecting and food/pharma applications.

	Model	Flow		Pressure		Plunger Dia.	Crankshaft		Power	Seal Kit	Valve Kit	Wt.
		GPM	l/min	PSI	bar		Stroke	Code				
1000 RPM	VXS-B 100/200 R	25.9	98.0	2900	200	32mm	42.0mm	8	50.3 EBHP	6061.B6	6061.Z2	150 lbs.
	VXS-B 130/160 R	32.8	124.0	2320	160	36mm	42.0mm	8	50.9 EBHP	6061.F1	6061.Z2	150 lbs.
	VXS-B 160/130 R	41.0	155.0	1885	130	40mm	42.0mm	8	51.7 EBHP	6061.F3	6061.Z2	150 lbs.



6180 140th Avenue NW
Ramsey, MN 55303

Ph: 651-785-0666
Fax: 800-732-2670

www.udorusa.com
www.boominator.com
info@udorusa.com



Scan this QR Code
for More Information

VXSB-S
2024A

MAX FLOW
MAX PRESSURE
RATED PUMP SPEED
POWER REQUIREMENT
LUBRICATION

41.0 GPM / 160 L/MIN
1995 PSI / 130 BAR
1000 RPM
52.0 HP ELECTRIC
128 OZ UDOR LUBE

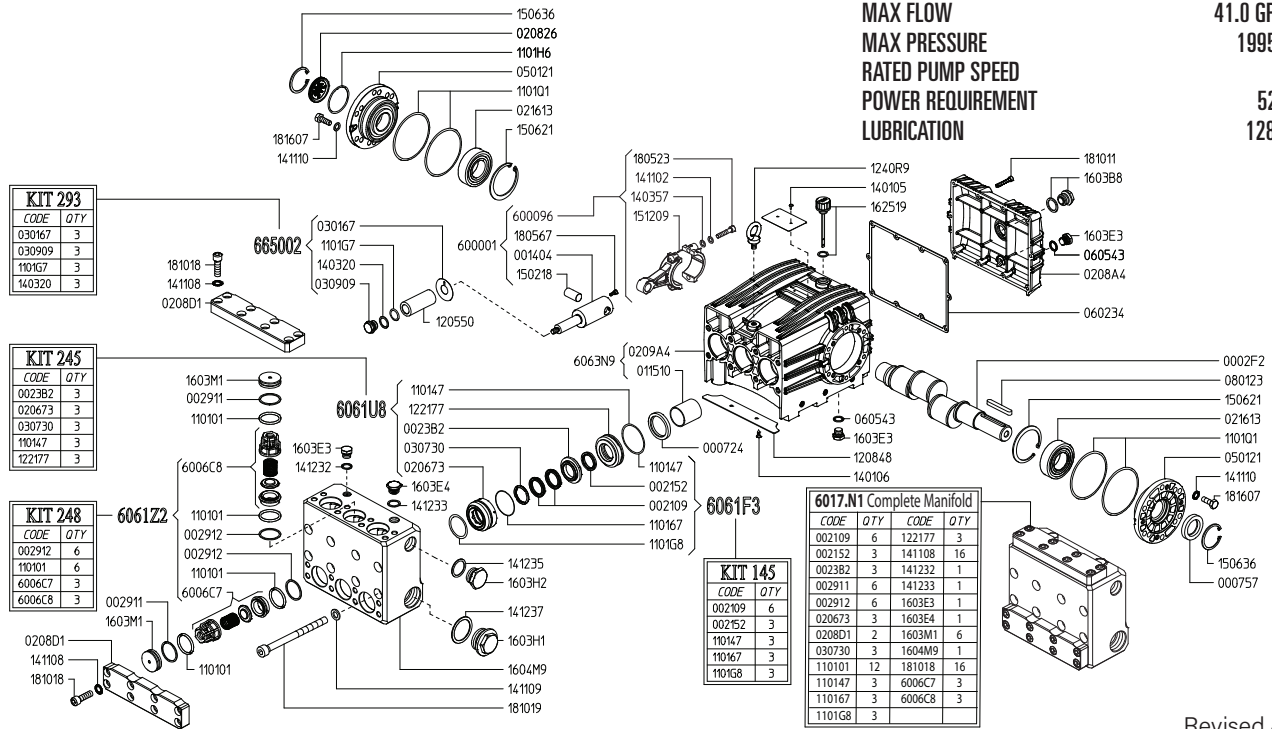

Revised 4-12-2024

Part #	Description	Qty
0002.F2	SHAFT	1
0007.24	OIL SEAL D40	3
0007.57	OIL SEAL D40	1
0014.04	PLUNGER GUIDE ROD D32/36/40	3
0021.09	WATER SEAL H.P. D40 ^{C E}	6
0021.52	WATER SEAL L.P. D40 ^{C E}	3
0023.B2	UPPER RING D40 ^{D E}	3
0029.11	PLUG RING ^E	6
0029.12	RING ^{B E}	6
0115.10	BUSHING D40	3
0206.73	SLEEVE D40 ^{D E}	3
0208.01	VALVE COVER ^E	2
0208.26	OIL SIGHT GLASS	1
0208.A4	BACK COVER	1
0209.A4	BODY	1
0216.13	BEARING D40	2
0301.67	DISC D32/36/40 ^A	3
0307.30	SPACER D40 ^{D E}	3
0309.09	NUT ^A	3
0501.21	BEARING FLANGE	2
0602.34	GASKET - BACK COVER	1
0605.43	GASKET D17	2
0801.23	KEY A10X8X70	1
1101.01	O-RING - VALVE CAP ^E	6
1101.01	O-RING - VALVE ^{B E}	6
1101.47	O-RING - PRESSURE RING ^{C D E}	3
1101.67	O-RING - SLEEVE ^{C E}	3
1101.G7	O-RING - PLUNGER BOLT ^A	3
1101.G8	O-RING - SLEEVE, FRONT ^{C E}	3
1101.H6	O-RING - OIL SIGHT GLASS	1
1101.Q1	O-RING - BEARING FLANGE	4
1205.50	CERAMIC PLUNGER D40	3
1208.48	PLATE	1
1221.77	PRESSURE RING D40 ^{D E}	3
1240.R9	LIFTING HOOK M10	1
1401.05	RIVET 3.5X8	2
1401.06	RIVET D4X10	2
1403.20	WASHER D8.4 ^A	3
1403.57	WASHER D8.4	6
1411.02	SERRATED WASHER D8	6
1411.08	WASHER ^E	16

Part #	Description	Qty
1411.09	WASHER	8
1411.10	WASHER	6
1412.32	GASKET ^E	1
1412.33	GASKET ^E	1
1412.35	GASKET	1
1412.37	GASKET	1
1502.18	PIN D20X34	3
1506.21	SNAP RING D80	2
1506.36	SNAP RING	1
1512.09	PLUG D5X20	6
1603.B8	OIL SIGHT GLASS	1
1603.E3	PLUG - CRANKCASE	2
1603.E3	PLUG - MANIFOLD ^E	1
1603.E4	PLUG ^E	1
1603.H1	PLUG	1
1603.H2	PLUG	1
1603.M1	VALVE PLUG ^E	6
1604.M9	HEAD ^E	1
1625.19	OIL PLUG	1
1805.23	ALLEN BOLT M8X40	6
1805.67	ALLEN BOLT M5X12	3
1810.11	ALLEN BOLT	10
1810.18	ALLEN BOLT ^E	16
1810.19	ALLEN BOLT	8
1816.07	HEX BOLT	12
6000.01	COMPLETE CONNECTING ROD ASS'Y	3
6000.96	CONNECTING ROD	3
6006.C7	VALVE ASSEMBLY - INLET ^{B E}	3
6006.C8	VALVE ASSEMBLY - DISCHARGE ^{B E}	3
6017.N3	COMPLETE MANIFOLD VXS D40	1
6063.N9	BODY ASSEMBLY	1
6061.F3	WATER SEAL KIT D40 (KIT 145)	1
6061.U8	BRASS RING KIT D40 (KIT 245)	1
6061.Z2	VALVE KIT (KIT 248)	1
6650.02	PLUNGER BOLT KIT (KIT 293)	1

^A Parts in 6650.02 (Kit 293).

^B Parts in 6061.Z2 (Kit 248).

^C Parts in 6061.F3 (Kit 145).

^D Parts in 6061.U8 (Kit 245)

^E Parts in 6017.N3 (Complete Manifold)

*Dimensional Drawings are
Shown in Millimeters.
To Convert to Inches,
Multiply Dimension x 0.03937*

VXS SERIES PUMPS - 35mm Solid Shaft

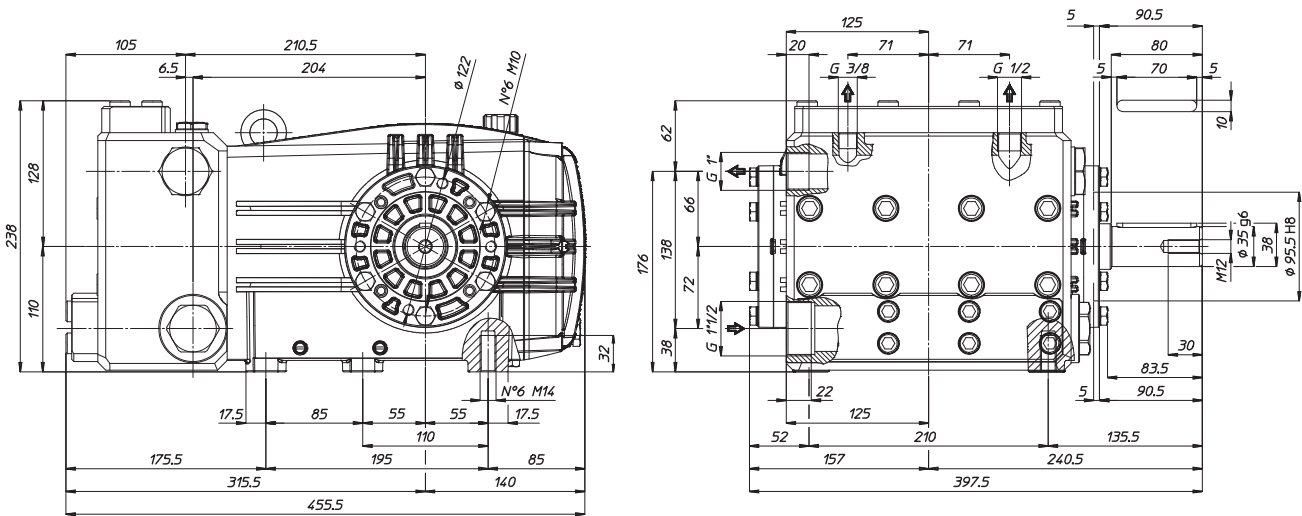

TORQUE SPECS

Ref.	Description	Ft./lb.	Nm	Loctite®
1	Head Bolts	103	140	-
2	Valve Caps	-	-	-
3	Inlet Cap	147	200	-
4	Outlet Cap	133	180	243
5	Bearing Flange Bolts	30	57	-
6	Rear Cover Bolts	8	11	-
7	Connecting Rod Bolts	19	25	243
8	Plunger Bolts	30	40	243
9	Valve Cover Bolts	66	90	-
10	Oil Drain Plug	8	11	-

