

- Heavy Duty Brass Manifold
- Solid Ceramic Plungers
- Stainless Steel Plunger Guides and Check Valves
- Replaceable PTFE Coated Body Guides
- Bronze Connecting Rods
- Heavy Duty Flat Base High Pressure Seals
- 1-1/2" BSP-F Inlet. 1" BSP-F Outlet
- 128 oz. Capacity Vented Oil Bath Crank Case
- Max Fluid Temp, 160°F

VX Series Plunger Pumps

VX Series industrial duty plunger pumps are rated at 15.9 to 52.6 GPM and pressures up to 5075 PSI.

Pumps are available in 1000 or 1200 RPM models with a 35mm solid, keyed shaft.

Applications include sewer jetting, hydro-excavation, UHP fire fighting, mining, misting, street cleaning and vehicle wash systems.

	Model	Flow		Pressure		Plunger Dia.	Crankshaft		Power	Seal Kit	Valve Kit	Wt.
		GPM	l/min	PSI	bar		Stroke	Code				
1000 RPM	VX-B 60/350 R	15.9	60.0	5075	350	28mm	35.0mm	5	50.3 EBHP	6061.E6	6061.E9	128 lbs
	VX-B 75/280 R	19.8	75.0	4060	280	28mm	42.0mm	8	51.3 EBHP	6061.F1	6061.E9	128 lbs
	VX-B 100/200 R	25.9	98.0	2900	200	32mm	42.0mm	8	50.3 EBHP	6061.E6	6061.E9	128 lbs
	VX-B 130/160 R	33.0	125.0	2320	160	36mm	42.0mm	8	51.3 EBHP	6061.F1	6061.E9	128 lbs
	VX-B 160/130 R	41.0	157.0	1885	130	40mm	42.0mm	8	52.3 EBHP	6061.F3	6061.E9	128 lbs
	VX-B 200/100 R	52.6	199.0	1450	100	45mm	42.0mm	8	51.0 EBHP	6061.F8	6061.E9	128 lbs
1200 RPM	VX-B 95/280 R	24.8	95.0	4060	280	28mm	42.0mm	8	70.0 EBHP	6061.N2	6061.N3	128 lbs

NOTE: All pump models available with left-hand drive option. Substitute 'L' for "R" in model number when ordering (ex. VX-B 100/200 L)



MAX FLOW
MAX PRESSURE
RATED PUMP SPEED
POWER REQUIREMENT
LUBRICATION

52.6 GPM / 199.0 L/MIN
1450 PSI / 100 BAR
1000 RPM
51.0 HP ELECTRIC
128 OZ UDOR LUBE

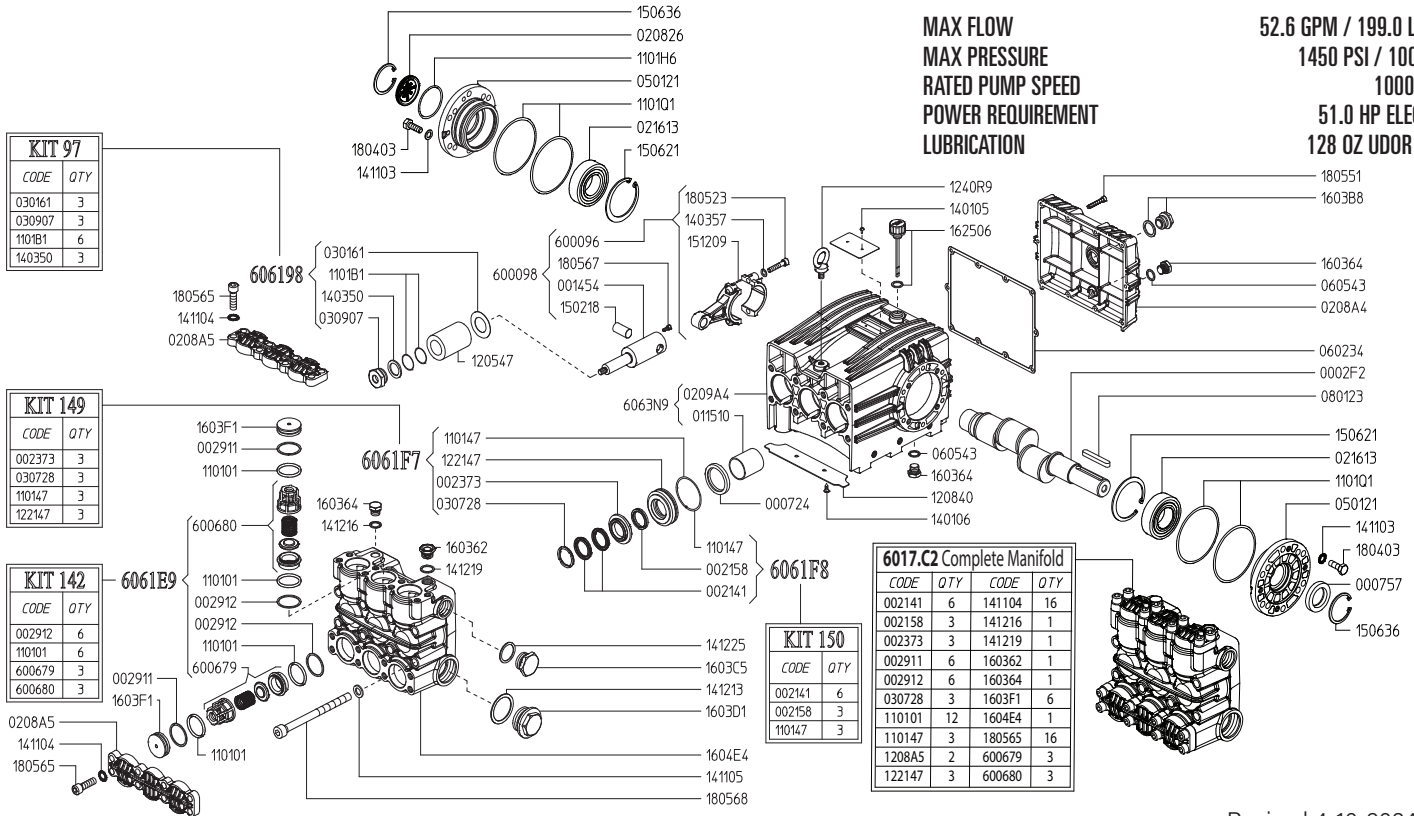

Revised 4-10-2024

Part #	Description	Qty
0002.F2	SHAFT	1
0007.24	OIL SEAL D40	3
0007.57	OIL SEAL D40	1
0014.49	PLUNGER GUIDE ROD D32/36/40	3
0021.41	WATER SEAL H.P. D45 ^{C E}	6
0021.58	WATER SEAL L.P. D45 BPT ^{C E}	3
0023.73	UPPER RING D45 ^{C E}	3
0029.11	PLUG RING ^E	6
0029.12	RING ^{B E}	6
0115.10	BUSHING D40	3
0208.26	OIL SIGHT GLASS	1
0208.A4	BACK COVER	1
0208.A5	COVER ^E	2
0209.A4	CRANKCASE	1
0216.13	BEARING D40	2
0301.61	DISC D45 SS ^A	3
0307.28	SPACER D45 ^{D E}	3
0309.07	NUT D45 ^A	3
0501.21	BEARING FLANGE	2
0602.34	BACK COVER GASKET	1
0605.43	GASKET D17	2
0801.23	KEY A10X8X70 UNI6604	1
1101.01	O-RING - VALVE CAP ^E	6
1101.01	O-RING - VALVE ^{B E}	6
1101.47	O-RING - PRESSURE RING ^{C D E}	3
1101.B1	O-RING - PLUNGER BOLT ^A	6
1101.H6	O-RING - OIL SIGHT GLASS	1
1101.Q1	O-RING - BEARING FLANGE	4
1205.47	CERAMIC PLUNGER D45	3
1208.40	PLATE	1
1221.47	PRESSURE RING D45 ^{D E}	3
1240.R9	LIFTING HOOK M10	1
1401.05	RIVET 3.5X8	2
1401.06	RIVET D4X10	2
1403.50	WASHER D25.2 ^A	3
1403.57	WASHER D8.4	6
1411.03	SERATED WASHER D10	12
1411.04	SERATED WASHER D12 ^E	16

Part #	Description	Qty
1411.05	SERATED WASHER D14	8
1412.13	BONDED WASHER D48.4	1
1412.16	BONDED WASHER D17.3 ^E	1
1412.19	BONDED WASHER D21.5 ^E	1
1412.25	BONDED WASHER D33.9 (G1")	1
1502.18	PIN D20X34	3
1506.21	SNAP RING D80	2
1506.36	SNAP RING D55	2
1512.09	PLUG D5X20	6
1603.62	PLUG G1/2 ^E	1
1603.64	PLUG G3/8 - CRANKCASE	2
1603.64	PLUG G3/8 - MANIFOLD ^E	1
1603.B8	OIL PLUG G3/4 + GASKET	1
1603.C5	PLUG G1"	1
1603.D1	PLUG G1-1/2"	1
1603.F1	VALVE PLUG ^E	6
1604.E4	HEAD PISTON D45 ^E	1
1625.06	OIL PLUG G1/2	1
1804.03	HEX BOLT M10X30	12
1805.23	ALLEN BOLT M8X40	6
1805.51	ALLEN BOLT M6X40	10
1805.65	ALLEN BOLT M12X40 ^E	16
1805.67	ALLEN BOLT M5X12	3
1805.68	ALLEN BOLT M14X130	8
6000.96	ROD ASSY "VX/VH/VY" BRONZE	3
6006.79	SUCTION VALVE ASSY W/O O-RING ^{B E}	3
6006.80	OUTLET VALVE ASSY W/O O-RING ^{B E}	3
6017.C2	COMPLETE MANIFOLD VX D45	1
6063.N9	CRANKCASE ASSEMBLY	1
6061.E8	PLUNGER KIT (KIT 141)	1
6061.E9	VALVE KIT (KIT 142)	1
6061.F3	WATER SEAL KIT D40 (KIT 145)	1
6061.F4	BRASS RING KIT D40 (KIT 146)	1

^A Parts in 6061.E8 (Kit 141).
^B Parts in 6061.E9 (Kit 142).
^C Parts in 6061.F3 (Kit 145).
^D Parts in 6061.F4 (Kit 146).
^E Parts in 6017.C2 (Complete Manifold)

*Dimensional Drawings are
Shown in Millimeters.
To Convert to Inches,
Multiply Dimension x 0.03937*

VX SERIES PUMPS UP TO 3000 PSI

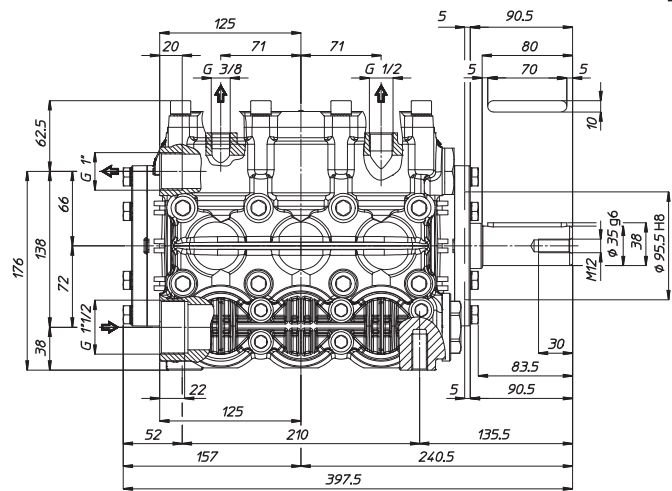
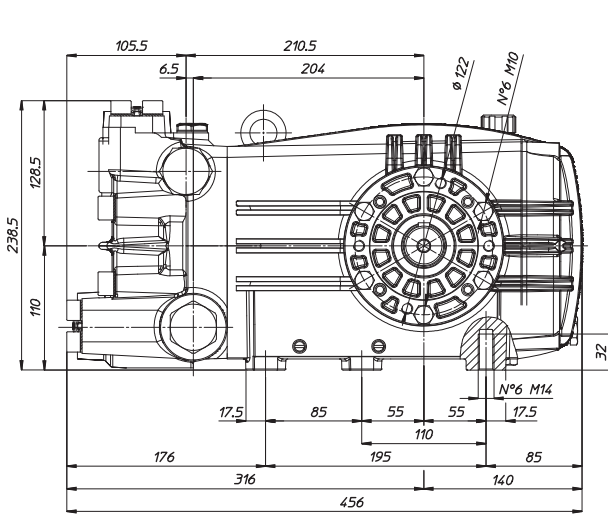

TORQUE SPECS

Ref.	Description	Ft./lb.	Nm	Loctite®
1	Head Bolts	103	140	-
2	Valve Caps	-	-	-
3	Inlet Cap	147	200	-
4	Outlet Cap	133	180	243
5	Bearing Flange Bolts	30	57	-
6	Rear Cover Bolts	8	11	-
7	Connecting Rod Bolts	19	25	243
8	Plunger Bolts	30	40	243
9	Valve Cover Bolts	66	90	-
10	Oil Drain Plug	8	11	-

