

- Brass Manifolds
- Industrial Quality Tapered Roller Bearings
- PTFE Packings
- Solid Ceramic Plungers
- Stainless Steel Check Valves
- Heated Treated Crank Shafts
- Stainless Steel Piston Guides
- Replaceable PTFE Body Guides

TC Series 24mm Keyed Solid Shaft Plunger Pumps

TC Series Tool Coolant plunger pumps are designed to withstand the wear and tear of the tool coolant industry. Pumps feature PTFE seals for increased durability in harsh conditions.

	Model	Flow		Pressure		Plunger Dia.	Crankshaft		Power	Seal Kit	Valve Kit	Wt.
		GPM	l/min	PSI	bar		Stroke	Code				
1750 RPM	TC 7.0/22 S	7.0	27	2200	150	22mm	17.0mm	X	11.0 EBHP	6061.D1	6061.03	35 lbs
	TC 8.0/22 S	8.0	30	2200	150	25mm	15.0mm	V	12.0 EBHP	6061.D1	6061.03	35 lbs
	TC 38/17 S	10.0	38	2500	170	28mm	15.0mm	V	17.5 EBHP	6061.C5	6061.03	35 lbs
	TC 44/15 S	11.5	44	2200	150	28mm	17.0mm	X	17.5 EBHP	6061.C2	6061.03	35 lbs

NOTE: All pump models available with left-hand drive option. Add 'L' to model number when ordering (ex. TC 44/15 SL)



MAX FLOW
MAX PRESSURE
RATED PUMP SPEED
POWER REQUIREMENT
LUBRICATION

7.0 GPM / 27 L/MIN
2200 PSI / 150 BAR
1750 RPM
11.0 HP ELECTRIC
34.5 OZ UDOR LUBE

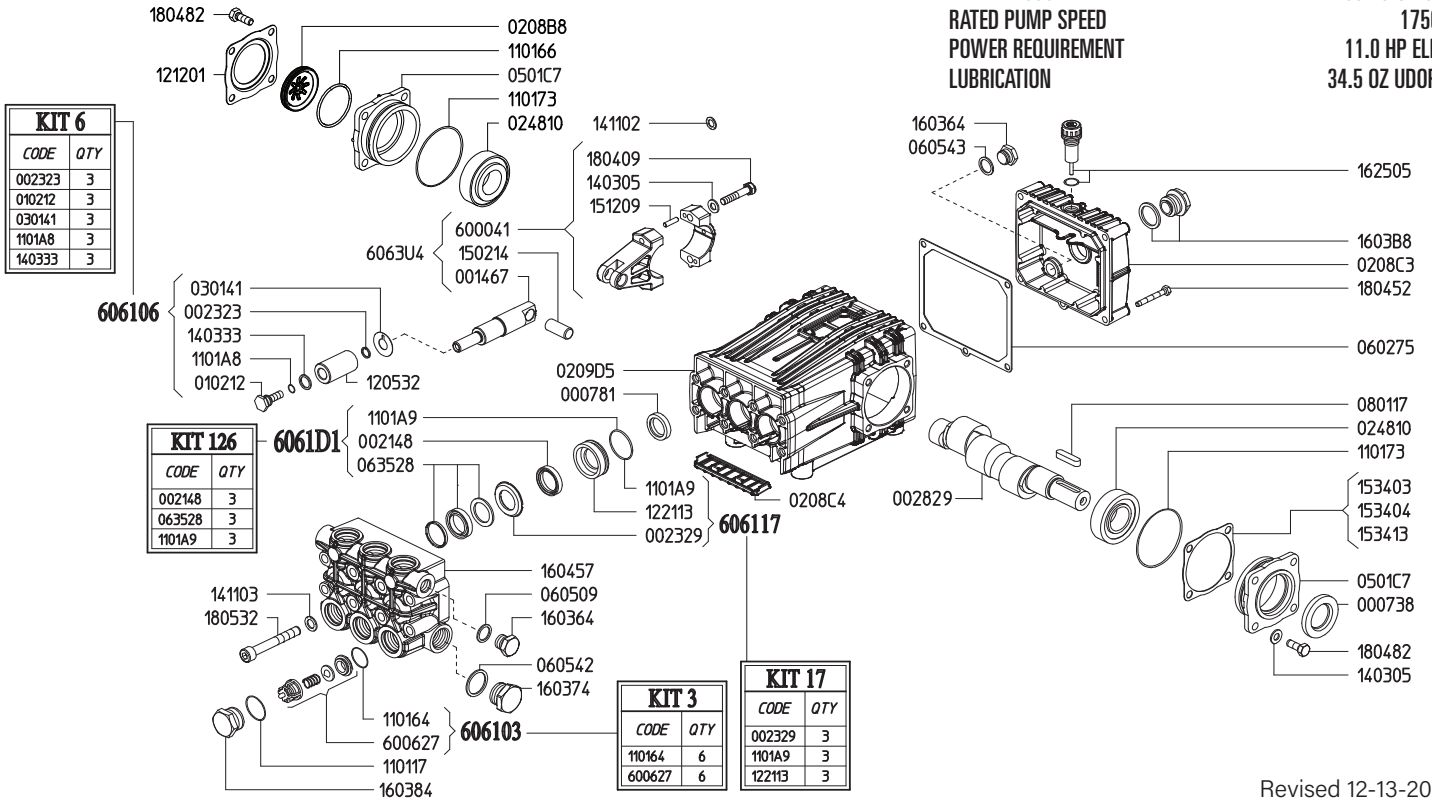

Revised 12-13-2023

Part #	Description	Qty
0007.38	OIL SEAL D30	1
0007.81	OIL SEAL D20	3
0014.67	PLUNGER GUIDE D22/25/28 "C/CK"	3
0021.48	LOW PRESSURE SEAL PTFE D22 ^C	3
0023.23	RING D10.4 ^B	3
0023.29	UPPER RING D20 "M/MK" ^{D E}	3
0028.29	MALE SHAFT D24	1
0102.12	PLUNGER BOLT ^B	3
0208.B8	OIL SIGHT GLASS	1
0208.C3	BACK COVER "C/CK"	1
0208.C4	COVER "C/CK"	1
0209.D5	CRANKCASE "C/CK/CH"	1
0248.10	ROLLER BEARING D30	2
0301.41	DISC ^B	3
0501.C7	BEARING HOLLOW FLANGE	2
0602.75	BACK COVER GASKET	1
0605.09	GASKET D17	1
0605.42	GASKET D27	1
0605.43	GASKET D17	1
0635.28	HIGH PRESS SEAL KIT D22 ^{C E}	3
0801.17	KEY A8X7X35 UNI16604	1
1101.17	O-RING D22.23 (RIF.130) ^E	6
1101.64	O-RING D20.24 (RIF 3081) 90SHORE ^{A E}	6
1101.66	O-RING - OIL SIGHT GLASS	1
1101.73	O-RING D67.95 (RIF.3268)	2
1101.A8	O-RING D9.25 (RIF.2037) ^B	3
1101.A9	O-RING D37.77 (RIF.3150) ^{C D E}	3
1205.32	CERAMIC PLUNGER D22	3
1212.01	RETAINER - OIL SIGHT GLASS	1

Part #	Description	Qty
1221.13	PRESSURE RING D22 ^{D E}	3
1403.05	WASHER D8.4	10
1403.33	WASHER D13.4 ^B	3
1411.02	SERATED WASHER D8	6
1411.03	SERATED WAHSER D10	8
1502.14	PIN D14X32	3
1512.09	PLUG D5X20 UNI1707	6
1534.03	SHIM 0.1 MM	1
1534.04	SHIM 0.2 MM	1
1534.13	SHIM 0.05 MM	1
1603.64	PLUG G3/8	2
1603.74	PLUG G3/4	1
1603.84	VALVE PLUG PISTON D22/25 ^E	6
1603.B8	OIL PLUG G3/4" + GASKET	1
1604.57	HEAD "C/G" PISTON D22/25 ^E	1
1625.05	OIL PLUG G3/8	1
1804.09	HEX BOLT M8X40	6
1804.52	HEX BOLT M6X45	5
1804.82	HEX BOLT M8X22	8
1805.32	ALLEN BOLT M10X75	8
6000.41	ROD ASSEMBLY	3
6006.27	VALVE ASSY W/O O-RING ^{A E}	6
6061.03	KIT 3 VALVE KIT	1
6061.06	KIT 6 PLUNGER KIT	1
6061.17	KIT 17 BRASS RING KIT D22 "C/CK/NX"	1
6061.D1	KIT 126 WATER SEAL KIT PTFE D22	1

^A Parts in 6061.03 (Kit 3).

^B Parts in 6061.06 (Kit 6).

^C Parts in 6061.D1 (Kit 126).

^D Parts in 6061.17 (Kit 17).

