



**UDOR**<sup>®</sup>  
**USA**

*World Leader in Diaphragm and Plunger Pumps*



**Pressure Washing Equipment & Applications**  
**Plunger Pumps, Diaphragm Pumps and Accessories**

## Plunger Pumps: The Heart of the Pressure Washing Industry

The wide variety of Udor plunger pumps available fits perfectly with the wide array of pressure washing applications in the industry. From small, portable machines to large truck or trailer mounted units and stationary industrial machines, Udor USA has a pump to fit your need.



**PN SERIES**  
0.5-4.0 GPM  
UP TO 2465 PSI  
Shown with SAE J609-A Flange  
for 3/4" Shaft Gas Engines  
Other drive options available



**B SERIES**  
3.4-6.0 GPM  
UP TO 2900 PSI  
Shown NEMA 182/184 TC Flange  
for 1-1/8" Shaft Electric Motors  
Other drive options available

### Standard Duty Plunger Pumps

Standard duty plunger pumps include a wide range of models in three frame sizes. Flow rates from 0.5 to 13.2 GPM and pressures up to 3000 PSI.

Drive options include solid shaft, gas engine flange, electric motor flange, gas engine gear reduction and hydraulic motor flange.

Applications include general pressure cleaning, sewer jetting, vehicle wash equipment and UHP fire fighting applications.

### Super Duty Plunger Pumps

Super duty plunger pumps include a wide range of models in two frame sizes. Flow rates from 3.4 to 13.2 GPM and pressures up to 5100 PSI.

Drive options include solid shaft, gas engine flange, gas engine gear reduction and hydraulic motor flange.

Applications include general pressure cleaning, sewer jetting, vehicle wash equipment and UHP fire fighting applications.

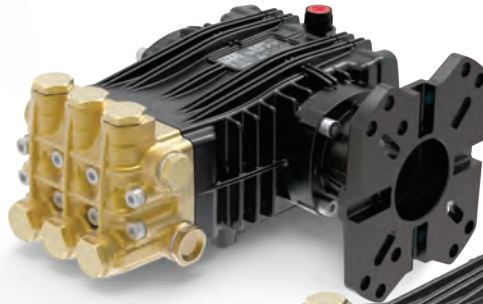

**BK SERIES**  
3.4-5.5 GPM  
UP TO 4350 PSI  
Shown with SAE J609-B Flange  
for 1" Shaft Gas Engines  
Other drive options available



**CK SERIES**  
4.5-13.2 GPM  
UP TO 5100 PSI  
Shown with Gear Reduction  
for 1" or 1-1/8" Shaft Gas Engines  
Other drive options available.

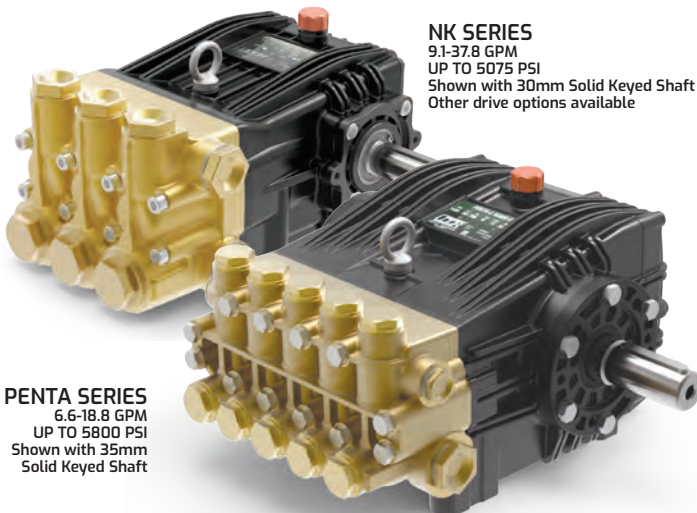

**NK SERIES**  
9.1-37.8 GPM  
UP TO 5075 PSI  
Shown with 30mm Solid Keyed Shaft  
Other drive options available

**PENTA SERIES**  
6.6-18.8 GPM  
UP TO 5800 PSI  
Shown with 35mm  
Solid Keyed Shaft

### Industrial Duty Plunger Pumps

Industrial duty plunger pumps include a wide range of models for high flow and high pressure applications.

Drive options include solid shaft, gas engine gear reduction and hydraulic motor flange.

Applications include general pressure cleaning, sewer jetting, vehicle wash equipment and UHP fire fighting applications.

# Pressure Washing Accessories



## TRIGGER SPRAY GUNS



**1215.18**  
10 GPM @ 4000 PSI  
3/8" FNPT Inlet  
1/4" FNPT Outlet



**ST-3002**  
25 GPM @ 7000 PSI  
1/2" FNPT Inlet  
1/2" FNPT Outlet



**0608.99**  
18 GPM @ 700 PSI  
1/2" FNPT Inlet  
1/2" FNPT Outlet



**1240.C5**  
18 GPM @ 400 PSI  
1/2" FNPT Inlet  
1/2" FNPT Outlet



**1215.29**  
16 GPM @ 350 PSI  
1/2" FNPT Inlet  
Adjustable Pattern Outlet

## BYPASS UNLOADERS



**UD7300**  
10.5 GPM @ 3625 PSI  
3/8" F Inlet  
3/8" F Outlet  
3/8" F Bypass



**UB1000**  
10.5 GPM @ 14500 PSI  
3/8" F Inlet  
3/8" F Outlet  
3/8" F Bypass



**UB150**  
21.0 GPM @ 2320 PSI  
1/2" F Inlet  
1/2" F Outlet  
1/2" F Bypass



**UB1500**  
53.0 GPM @ 2200 PSI  
1" F Inlet  
1" F Outlet  
1" F Bypass



**SV500**  
21.0 GPM @ 7250 PSI  
1/2" F Inlet  
3/8" F Bypass



**UB600F**  
53.0 GPM @ 2610 PSI  
3/4" F Inlet  
1/2" F Bypass



**UD555FSS**  
7.0 GPM @ 2000 PSI  
3/8" F Inlet  
3/8" F Bypass



**UD555FT**  
7.0 GPM @ 2000 PSI  
3/8" F Inlet  
3/8" F Outlet  
3/8" F Bypass

## DRIVE COMPONENTS



### DRIVE COMPONENTS

Udor USA offers a broad range of drive components to accommodate your equipment needs.

- Gear reductions for engines up to 75 HP
- Mounting flanges for gas, electric and hydraulic applications
- Shaft couplers for electric and hydraulic motors
- Mounting rails and hardware

## MORE ACCESSORIES



### POLYPROPYLENE INLET FILTERS

- 1", 1-1/4" and 1-1/2" Models
- 32 Mesh - for Plunger Pump Applications
- 16 Mesh - for Diaphragm Pump Applications



### UDOR LUBE / UDOR LUBE SYNTHETIC

SAE 40W non-detergent lubricant. Specially formulated for use in Udor diaphragm & plunger pumps.

- Non-Detergent. Non-Foaming
- Rust Inhibitors
- Anti-wear Agents
- Resists Breakdown Due to Oxidation
- Synthetic Oil Recommended for Cold Weather Uses

# Plunger Pump Features

- 1 Anodized Die-Cast Aluminum Crankcase
- 2 Large Diameter Valve Caps with Increased Thread Depth
- 3 Heavy Duty Brass Manifold with Internal and External Bracing
- 4 Stainless Steel Stepped Plunger Guide for Increased Seal Life
- 5 Bottom Mount O-Ring and Back-Up Ring to Prevent Thread Damage
- 6 Stainless Steel Conical Valve Assembly for Increased Efficiency
- 7 High-Polished Solid Ceramic Plungers
- 8 Heavy Duty Bronze Connecting Rods
- 9 Heavy Duty Tapered Roller Bearings
- 10 Deeper Back Cover for Increased Oil Capacity
- 11 Heat Treated Crank Shaft

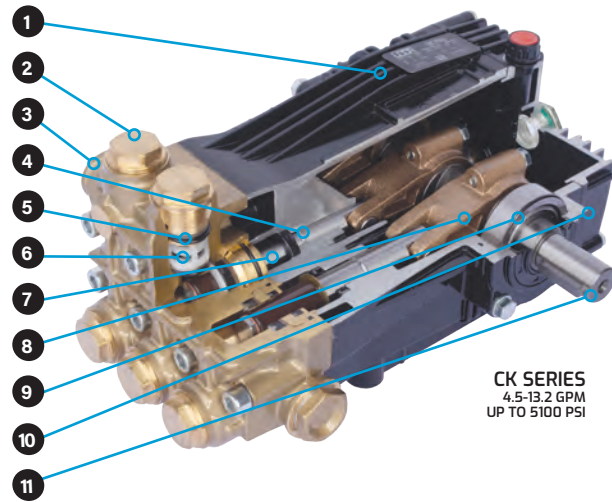

CK SERIES  
4.5-13.2 GPM  
UP TO 5100 PSI

# Diaphragm Pump Features

## Diaphragm Pumps

Udor USA offers diaphragm pump models with two, three, four, five or six diaphragm configurations. Flow rates from 2.0 - 106 GPM and pressures up to 725 PSI.

Models are available for many soft wash and pressure washing industries. These pumps are also recommended for horticultural and agricultural spraying, aggressive fluid, fire fighting, aircraft de-icing, and hydrostatic testing applications.

Contact Udor USA for more information on specific applications.

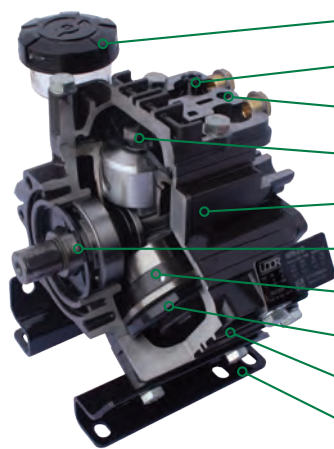

- 1 Oil Level Sight Glass / Reservoir
- 2 Stainless Steel Check Valves
- 3 Internally Manifolded Crankcase
- 4 1-Piece Stainless Steel Diaphragm Bolts
- 5 Anodized Die-Cast Aluminum Crankcase
- 6 Heat Treated, Bearing Supported Crankshaft
- 7 Heat Treated, Self-Lubricating Piston Sleeves
- 8 Udor **GREENTECH** Diaphragms
- 9 Anodized Aluminum Heads
- 10 Mounting Rails



ZETA 40P VAGR3/4  
10.5 GPM  
UP TO 300 PSI  
Gear Reduction for  
3/4" Shaft Gas Engines  
Other drive options available

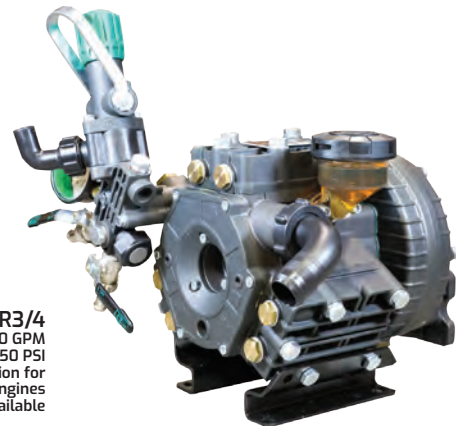

KAPPA 55GR3/4  
15.0 GPM  
UP TO 350 PSI  
Gear Reduction for  
3/4" Shaft Gas Engines  
Other drive options available

# UDOR<sup>®</sup>

USA

World Leader in  
Diaphragm and Plunger Pumps

6180 140th Avenue NW  
Ramsey, MN 55303

Ph: 651-785-0666  
Fax: 800-732-2670

www.udorusa.com  
sales@udorusa.com

Scan this QR Code  
to Visit [www.udorusa.com](http://www.udorusa.com)



FLYER  
PW226A