

- 316 Stainless Steel Manifolds
- 316 Stainless Steel Valves
- 316 Stainless Steel Plunger Rods & Nuts
- 304 Stainless Steel Exterior Bolts
- Solid Ceramic Plungers
- 1/2" BSP-F Inlet. 3/8" BSP-F Outlet
- PTFE Style Packings
- 11.5 oz. Oil Capacity

PSC Series 24mm Keyed Solid Shaft Plunger Pumps

PSC Series stainless steel plunger pumps include a wide range of models with flow rates from 1.5 to 3.4 GPM and pressures up to 2175 PSI.

Models are also available with a 5/8" hollow shaft and NEMA 56C electric motor flange

These pumps feature stainless steel wetted and exterior components to withstand the harsh environment of salt water applications.

PSC Series pumps are well suited for de-salination, disinfecting and food/pharma applications.

	Model	Flow		Pressure		Plunger Dia.	Crankshaft		Power	Seal Kit	Valve Kit	Wt.
		GPM	l/min	PSI	bar		Stroke	Code				
1450 RPM	PSC 06/15 S	1.5	5.7	2175	150	18mm	5.5mm	D	2.2 EBHP	6061.B1	6061.D7	13.5 lbs
	PSC 08/15 S	2.2	8.2	2175	150	18mm	8.0mm	4	3.3 EBHP	6061.B1	6061.D7	13.5 lbs
	PSC 11/15 S	2.9	11.0	2175	150	18mm	10.5mm	O	4.2 EBHP	6061.B1	6061.D7	13.5 lbs
	PSC 13/15 S	3.4	13.0	2175	150	18mm	12.5mm	S	5.0 EBHP	6061.B1	6061.D7	13.5 lbs



MAX FLOW
MAX PRESSURE
RATED PUMP SPEED
POWER REQUIREMENT
LUBRICATION

3.0 GPM / 11 L/MIN
2000 PSI / 136 BAR
1450 RPM
5.0 HP ELECTRIC
11.5 OZ UDOR LUBE

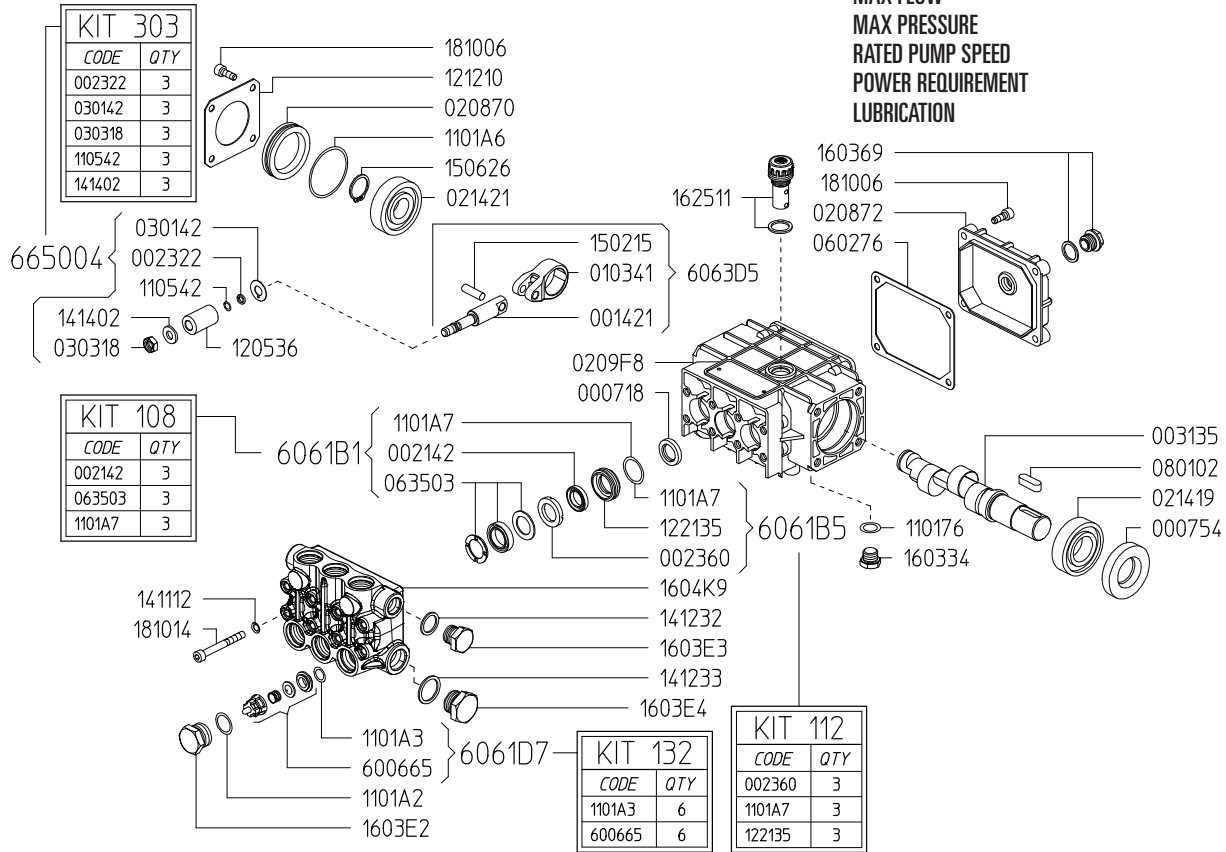

Revised 12-18-2023

Part #	Description	Qty
0007.18	OIL SEAL D15	3
0007.54	OIL SEAL D25	1
0014.21	PLUNGER GUIDE D18 "PS"	3
0021.42	WATER SEAL L.P. D18 BPE ^B	3
0023.22	RING D6.3 ^D	3
0023.60	UPPER RING D18 "PS" SS ^C	3
0031.35	MALE SHAFT "PN" D24	1
0103.41	CONNECTING ROD "PN/PS"	3
0208.70	COVER "PN"	1
0208.90	BACK COVER "PN/PK/PW/PS"	1
0209.56	CRANKCASE "PN/PS"	1
0214.19	BALL BEARING D25	1
0214.21	BALL BEARING D20	1
0301.42	DISC "PN/PK/PKWT/PS" ^D	3
0303.18	NUT "PN/PK" SS ^D	3
0602.76	BACK COVER GASKET "PN/PK/PW/PS"	1
0605.49	GASKET D13	1
0635.03	HIGH PRESS. SEAL KIT D15 "PN" ^B	3
0801.02	KEY A8A7A25 UNI6604-69	1
1101.A2	O-RING - VALVE CAP	6
1101.A3	O-RING - VALVE ^A	6
1105.42	O-RING - PLUNGER ^D	3
1101.A6	O-RING - BEARING COVER	1
1101.A7	O-RING - LP SEAL RETAINER ^{B,C}	3
1205.36	CERAMIC PLUNGER D18 "PN/PS"	3

Part #	Description	Qty
1212.10	METAL COVER "PN"	1
1221.35	PRESSURE RING D18 "PS" SS ^C	3
1412.32	GASKET - DISCHARGE PLUG	1
1412.33	GASKET - INLET PLLUG	1
1414.02	WASHER D8.4 SS ^D	3
1502.15	PIN D7X25.5	3
1506.26	SNAP RING D20	1
1603.68	PLUG G1/4	1
1603.69	OIL PLUG G1/4 + GASKET	1
1603.E2	VALVE PLUG "PS/MS" SS	6
1603.E3	PLUG G3/8 SS	1
1603.E4	PLUG G1/2 SS	1
1604.K9	HEAD "PS" PISTON D18 SS	1
1625.10	OIL PLUG G3/8 "PN"	1
1810.06	ALLEN SCREW M6X16 DIN912 A4-70 SS	4
1810.14	ALLEN SCREW M6X60 UNI5931 SS	8
1810.15	ALLEN SCREW M6X35 UNI5931 SS	4
6006.65	VALVE ASSY "PS/MS" W/O O-RING ^A	6
6061.B1	WATER SEAL KIT D18 "PS" (KIT 108)	
6061.B5	SS RING KIT D18 "PS" (KIT 112)	
6061.D7	VALVE KIT "PS/MS" 110 (KIT 132)	
6650.04	PLUNGER KIT D18 "PS" (KIT 303)	

^A Parts in 6061.D7 (Kit 132).
^B Parts in 6061.B1 (Kit 108).
^C Parts in 6061.B5 (Kit 112).
^D Parts in 6650.04 (Kit 303).

*Dimensional Drawings are
Shown in Millimeters.
To Convert to Inches,
Multiply Dimension x 0.03937*

PS SERIES PUMPS - 24MM SOLID SHAFT

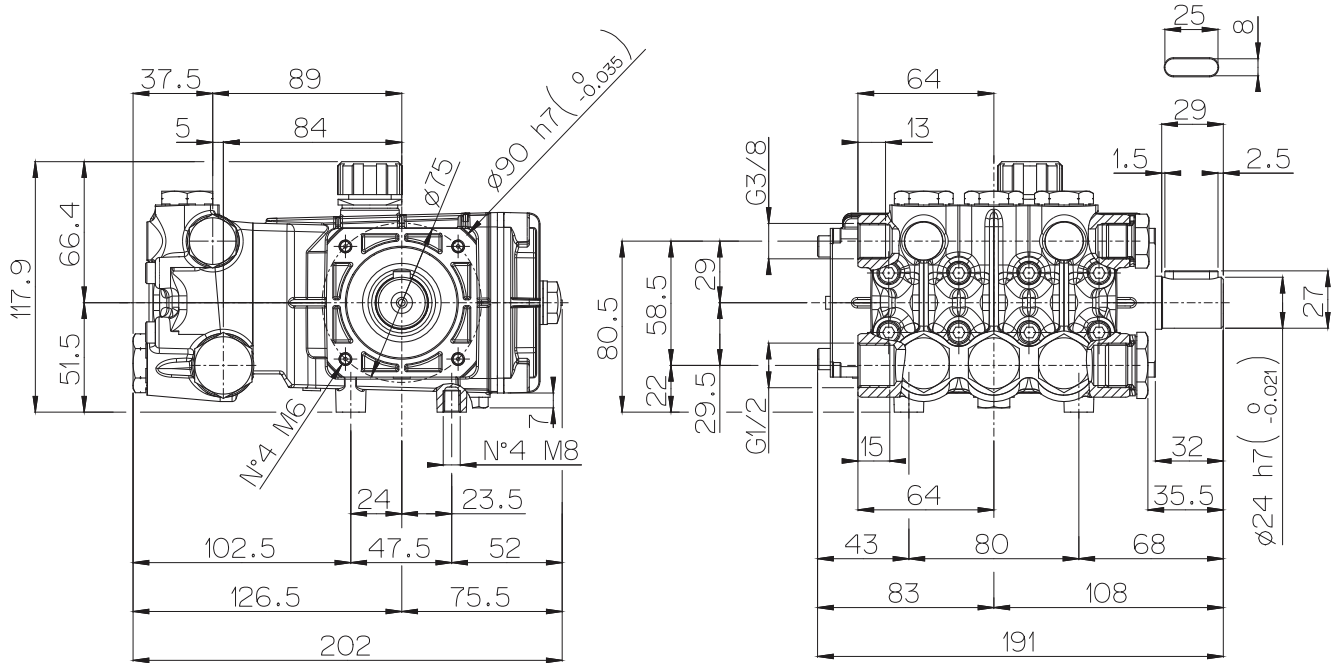

TORQUE SPECS

Ref.	Description	Ft./lb.	Nm	Loctite®
1	Head Bolts	8	11	-
2	Valve Caps	75	100	243
3	Inlet Cap	60	80	-
4	Outlet Cap	60	80	243
5	Bearing Flange Bolts	8	11	-
6	Rear Cover Bolts	8	11	-
7	Connecting Rod Bolts	-	-	-
8	Plunger Bolts	11	15	270
9	Valve Cover Bolts	-	-	-
10	Oil Drain Plug	6	8	-

