

## High Temperature Solid Shaft Models

24mm Keyed Solid Shaft  
1450 RPM



- Nickel Plated Brass Manifold
- Heat Treated Crankshaft
- Solid Ceramic Plungers
- Stainless Steel Valve Caps
- Stainless Steel Piston Guides and Check Valves
- Industrial Quality Ball Bearings and Needle Bearings
- High Temperature Seals for Hot Water Applications
- 11.5 oz. Capacity Vented Oil Bath Crank Case
- 1/2" BSP-F Inlet. 3/8" BSP-F Outlet
- Max Fluid Temp, 185°F

### PKWT Series 24mm Keyed Solid Shaft Plunger Pumps

PKWT Series high temperature rated plunger pumps include a range of models with flow rates from 2.9 to 3.4 GPM and pressures up to 2175 PSI.

These pumps are designed and engineered with high temperature seals and nickel plated manifolds to withstand the demands of hot water applications

PKWT series pumps are well suited for general pressure cleaning, disinfecting and food/pharma applications.

	Model	Flow		Pressure		Plunger Dia.	Crankshaft		Power	Seal Kit	Valve Kit	Wt.
		GPM	l/min	PSI	bar		Stroke	Code				
1450	PKWTC 11/15 S	2.9	11.0	2175	150	18mm	10.5mm	O	4.2 EBHP	6061.B1	6061.D7	13.5 lbs
RPM	PKWTC 13/15 S	3.4	13.0	2175	150	18mm	12.5mm	S	5.0 EBHP	6061.B1	6061.D7	13.5 lbs
Rail Kit	8702.10	Standard 7/8" Rail Kit for P Series Solid Shaft Pumps										
NOTE: All pump models available with left-hand drive option. Add 'L' to model number when ordering (ex. PKWTC 13/17 SL)												



MAX OUTPUT  
MAX OUTPUT  
RATED PUMP SPEED  
POWER REQUIREMENT  
LUBRICATION

3.4 GPM / 13.0 L/MIN  
2175 PSI / 150 BAR  
1450 RPM  
5.0 HP ELECTRIC  
11.5 OZ UDOR LUBE

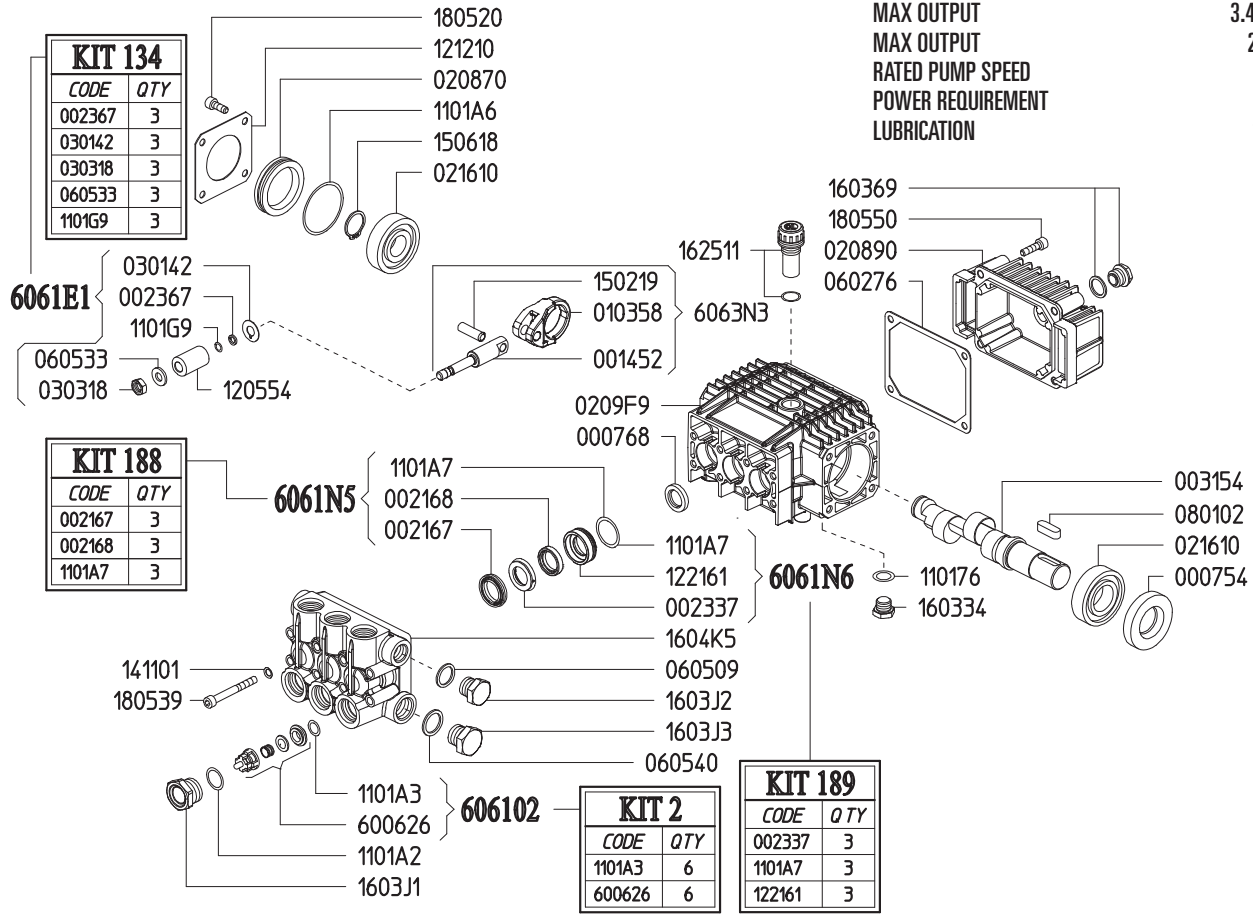

Revised 12-15-2023

Part #	Description	Qty	Part #	Description	Qty
000718	OIL SEAL D15X24X5	3	1205.54	CERAMIC PLUNGER D18	3
0007.54	OIL SEAL D25X52X10	1	1212.10	METAL COVER	1
0014.52	PLUNGER GUIDE D15/18	3	1221.61	PRESSURE RING D18 <sup>D</sup>	3
0021.67	WATER SEAL H.P. D18 <sup>C</sup>	3	1411.01	SERATED WASHER D6	8
0021.68	WATER SEAL L.P. D18 <sup>C</sup>	3	1502.19	PIN D8X26	3
0023.37	UPPER RING D18 <sup>D</sup>	3	1506.18	SNAP RING D25	1
0023.67	RING D5.2X8X1.3 <sup>B</sup>	3	1603.J1	VALVE PLUG PISTON D15/18/20	6
0031.54	MALE SHAFT D24	1	1603.J2	PLUG G3/8	1
0103.58	CONNECTING ROD	3	1603.J3	PLUG G1/2	1
0208.70	COVER	1	1603.67	PLUG G1/4	1
0208.90	BACK COVER - DEEP	1	1603.69	OIL PLUG G1/4+GASKET	1
0209.A3	CRANKCASE	1	1604.K5	HEAD PISTON D15/18	1
0216.10	ROLLER BEARING D25	2	1625.11	OIL PLUG G3/8	1
0301.42	DISC <sup>B</sup>	3	1805.20	ALLEN BOLT M6X16	4
0303.18	NUT M8XH5 <sup>B</sup>	3	1805.39	ALLEN BOLT M6X60	8
0602.76	BACK COVER GASKET	1	1805.50	ALLEN BOLT M6X35	4
0605.09	GASKET D17X23X1.5 (G3/8)	1	6006.26	VALVE ASSEMBLY W/O O-RING <sup>A</sup>	6
0605.33	GASKET D8X14X2 <sup>B</sup>	3	6063.N3	COMPLETE ROD ASSEMBLY D15/18	3
0605.40	GASKET D21.5X27X1.5 (G1/2) ALL	1	6061.02	VALVE KIT (KIT 2)	1
0605.49	GASKET D13X19X1.5	1	6061.E1	PLUNGER KIT D18 (KIT 134)	1
0801.02	KEY A8X7X25	1	6061.N5	WATER SEAL KIT D18 (KIT 188)	1
1101.A2	O-RING - VALVE CAP	6	6061.N6	BRASS RING KIT D18 (KIT 189)	1
1101.A3	O-RING - VALVE <sup>A</sup>	6			
1101.A6	O-RING - BEARING COVER	1			
1101.A7	O-RING - PRESSURE RING <sup>C D</sup>	3			
1101.G9	O-RING - PLUNGER GUIDE <sup>B</sup>	3			

<sup>A</sup> Parts in 6061.02 (Kit 2).  
<sup>B</sup> Parts in 6061.E1 (Kit 134).  
<sup>C</sup> Parts in 6061.E2 (Kit 188).  
<sup>D</sup> Parts in 6061.N6 (Kit 189).

*Dimensional Drawings are  
Shown in Millimeters.  
To Convert to Inches,  
Multiply Dimension x 0.03937*

## PK SERIES PUMPS - 24MM SOLID SHAFT

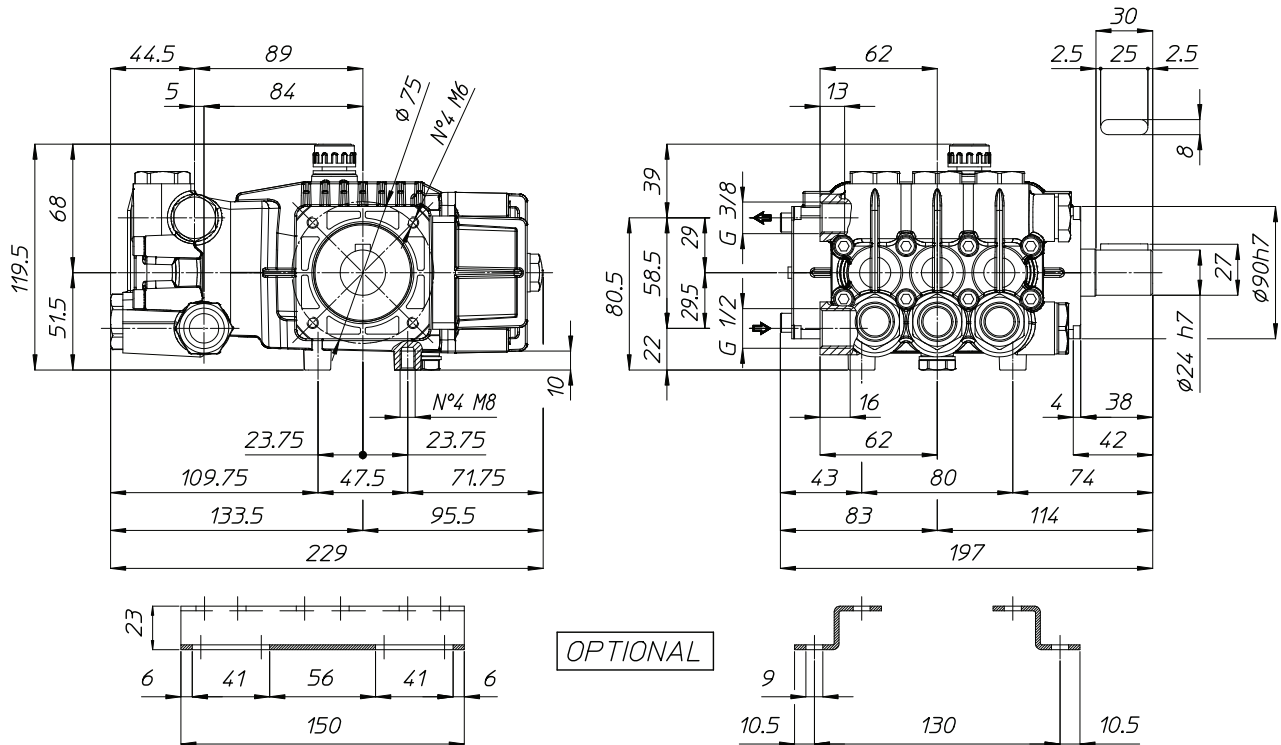

## TORQUE SPECS

Ref.	Description	Ft./lb.	Nm	Loctite®
1	Head Bolts	8	11	-
2	Valve Caps	75	100	243
3	Inlet Cap	80	110	-
4	Outlet Cap	60	80	243
5	Bearing Flange Bolts	8	11	-
6	Rear Cover Bolts	8	11	-
7	Connecting Rod Bolts	-	-	-
8	Plunger Bolts	11	15	270
9	Valve Cover Bolts	-	-	-
10	Oil Drain Plug	6	8	-

