

Gear Reduction, Gas Engine Models

1-1/8" or 1-7/16" Hollow Shaft
2.2:1 Gear Reduction Drive

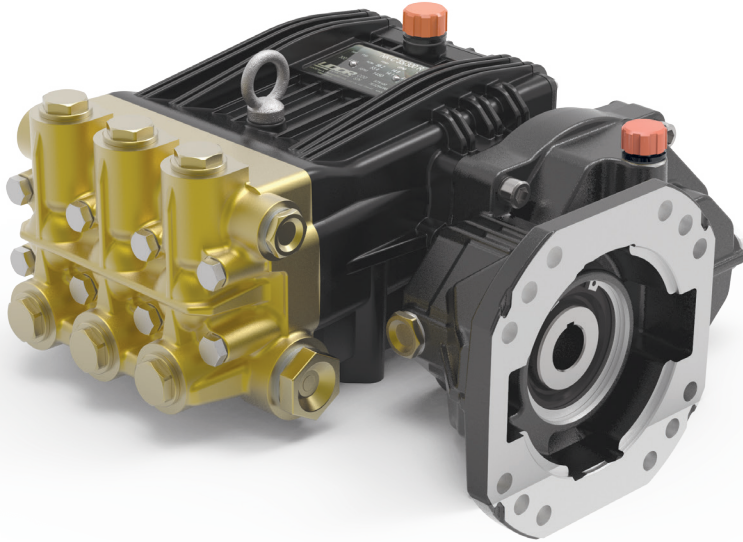

- Brass Manifold
- Solid Ceramic Plungers
- Stainless Steel Plunger Guides and Check Valves
- Bronze Connecting Rods
- Heavy Duty Flat Base High Pressure Seals
- 57.6 oz. Capacity Vented Oil Bath Crank Case
- Max Fluid Temp, 160°F
- 1-1/8" or 1-7/16" Hollow Shaft. Please Specify
- For Kohler® Engine Applications, add 'K' to Model#

Model Examples:

NKC 35/350 GR 1-1/8 (Std B&S, Honda)
NKC 47/350 GR 1-7/16 K (Kohler)

NKC Series Gas Engine, Gear Reduction Drive Plunger Pumps

NKC Series super duty plunger pumps include a wide range of models with flow rates from 9.1 to 23.0 GPM and pressures up to 5000 PSI.

Other drive options include a 30mm solid shaft or hydraulic motor flange

Applications include general pressure cleaning,, construction, hydro-excavation UHP fire fighting, mining and street cleaning.

	Model	Flow		Pressure		Plunger Dia.	Crankshaft		Power	Seal Kit	Valve Kit	Wt.
		GPM	l/min	PSI	bar		Stroke	Code				
Gear Reduction	A NKC 35/350 GR	9.1	34.6	5000	340	22mm	22.0mm	3	40 HP Gas	6061.10	6061.J1	92 lbs
	A NKC 47/350 GR	12.5	47.1	3600	240	22mm	30.0mm	F	40 HP Gas	6061.10	6061.J1	92 lbs
	A NKC 55/300 GR	14.1	53.4	3200	220	22mm	34.0mm	7	40 HP Gas	6061.10	6061.J1	92 lbs
	A NKC 60/250 GR	16.1	60.9	2800	190	25mm	30.0mm	F	40 HP Gas	6061.11	6061.94	92 lbs
	A NKC 70/250 GR	18.2	69.0	2500	170	25mm	34.0mm	7	40 HP Gas	6061.11	6061.94	92 lbs
	B NKC 75/170 GR	19.9	75.1	2300	160	28mm	30.0mm	F	40 HP Gas	6061.12	6061.M6	92 lbs
	B NKC 85/170 GR	23.0	87.0	2000	140	28mm	34.0mm	7	40 HP Gas	6061.12	6061.M6	92 lbs

* NOTE: Pressure ratings are based on 40 HP maximum gearbox capacity.



MAX FLOW 23.0 GPM / 87.0 L/MIN
MAX PRESSURE* 2000 PSI / 140 BAR
RATED PUMP SPEED 1450 RPM
POWER REQUIREMENT 40.0 HP GAS
LUBRICATION 57.6 OZ UDOR LUBE

* Max Pressure Based on 40 HP Max Gearbox Capacity

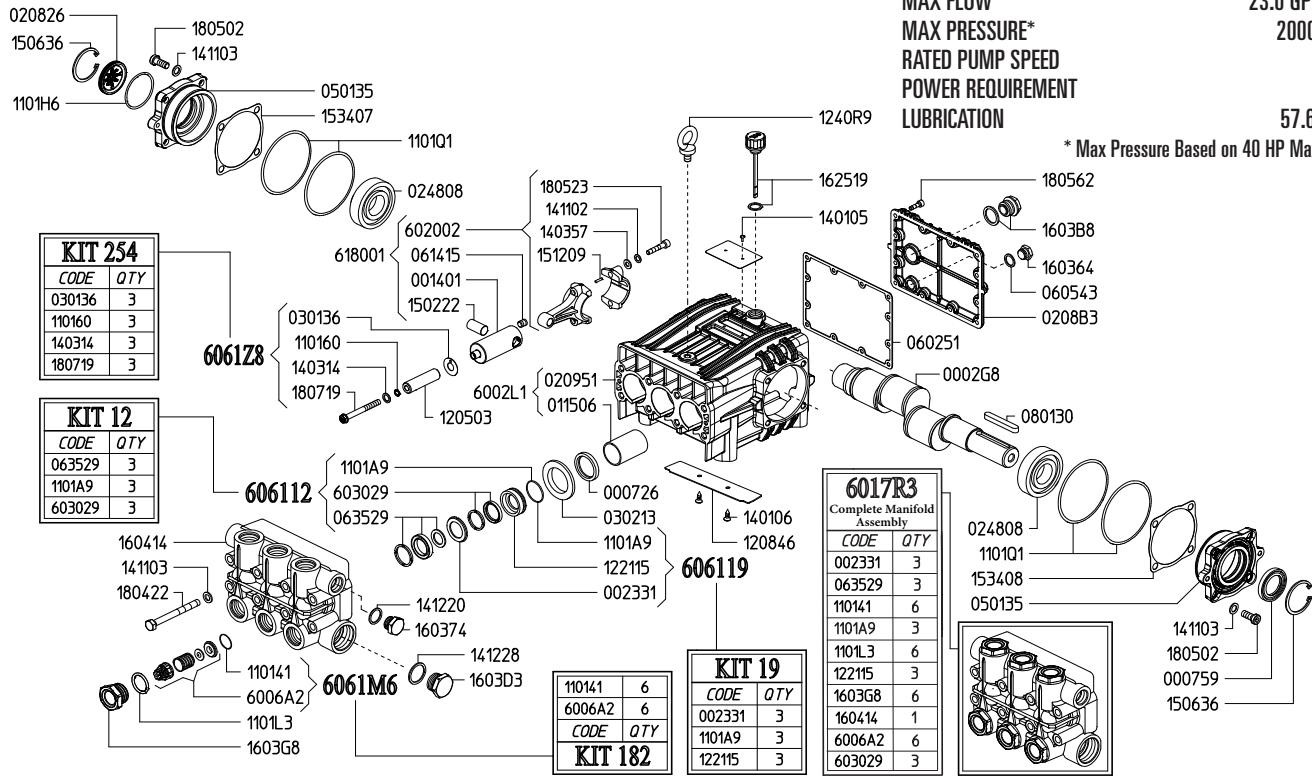

KIT 254	
CODE	QTY
030136	3
110160	3
140314	3
180719	3

KIT 12	
CODE	QTY
063529	3
1101A9	3
603029	3

6017R3 Complete Manifold Assembly	
CODE	QTY
002331	3
063529	3
110141	6
1101A9	3
1101L3	6
122115	3
1603G8	6
160414	1
6006A2	6
603029	3

KIT 182	
CODE	QTY
110141	6
6006A2	6

KIT 19	
CODE	QTY
1101A9	3
122115	3

Revised 2-23-2022

Part #	Description	Qty	Part #	Description	Qty
0002.G8	CRANKSHAFT 30MM	1	1412.20	BONDED WASHER D27.05 (G3/4")	1
0007.26	OIL SEAL D35	3	1412.28	BONDED WASHER D42.9 (G1-1/4")	1
0007.59	OIL SEAL	1	1502.22	PIN	3
0014.01	PLUNGER GUIDE	3	1506.36	SNAP RING	2
0023.31	UPPER RING D28 ^{D E}	3	1512.09	PIN D5X20	6
0115.06	BUSHING D35	3	1534.07	GASKET - BEARING FLANGE	1
0208.26	OIL SIGHT GLASS	1	1534.08	SPACER / GASKET	1
0208.B3	BACK COVER	1	1603.64	PLUG 3/8"	1
0209.51	CRANKCASE	1	1603.74	PLUG G3/4"	1
0248.08	BALL BEARING	2	1603.B8	OIL SIGHT GLASS W/GASKET	1
0301.36	SLINGER RING ^A	3	1603.D3	PLUG G1-1/4"	1
0302.13	SPACER	3	1603.G8	VALVE PLUG D28/30 ^E	6
0501.35	BEARING FLANGE	2	1604.14	HEAD D28/30 ^E	1
0602.51	GASKET - PUMP BODY	1	1625.19	OIL CAP W/GASKET	1
0605.43	GASKET - D17	1	1804.22	HEX BOLT M10X100	8
0614.15	SET SCREW	3	1805.02	ALLEN BOLT	8
0635.29	HIGH PRESSURE SEAL KIT D28 ^{B E}	3	1805.23	ALLEN BOLT M8X40	6
0801.30	KEY	1	1805.62	ALLEN BOLT M6X20	12
1101.41	O-RING - VALVE ^{C E}	6	1807.19	PLUNGER BOLT ^A	3
1101.60	O-RING - PLUNGER BOLT ^A	3	6002.L1	CRANKCASE ASSEMBLY	1
1101.A9	O-RING - PRESSURE RING ^{B D E}	3	6006.A2	VALVE ASSEMBLY W/O O-RING ^{C E}	6
1101.H6	O-RING - OIL SIGHT GLASS	1	6017.R3	COMPLETE MANIFOLD ASSEMBLY NK D28	1
1101.L3	O-RING - VALVE PLUG ^E	6	6020.02	CONNECTING ROD	3
1101.Q1	O-RING - BEARING FLANGE	4	6030.29	LOW PRESSURE SEAL KIT D28 ^{B E}	3
1205.03	CERAMIC PLUNGER D28	3	6180.01	CONNECTING ROD ASS'Y COMPLETE	3
1208.46	PLATE	1	6061.12	WATER SEAL KIT (KIT 12)	1
1221.15	PRESSURE RING D28 ^{D E}	3	6061.19	BRASS RING KIT D28 (KIT 19)	1
1240.R9	LIFTING HOOK M10	1	6061.M6	VALVE KIT (KIT 182)	1
1401.05	RIVET 3.5X8	2	6061.Z8	PLUNGER BOLT KIT (KIT 254)	1
1401.06	RIVET D4X10	2			
1403.14	WASHER - PLUNGER BOLT ^A	3			
1403.57	WASHER M8	6			
1411.02	SERRATED WASHER D8	6			
1411.03	WASHER	16			

^A Parts in 6061.Z8 (Kit 254).
^B Parts in 6061.12 (Kit 12).
^C Parts in 6061.M6 (Kit 182).
^D Parts in 6061.19 (Kit 19).
^E Parts in 6017.R3 (Complete Manifold Assembly).

**GAS ENGINE GEAR REDUCTION FOR
NK-SERIES PLUNGER PUMPS**
on up to 40 HP B/S or HONDA GAS ENGINES with 1-1/8" SHAFTS
REQUIRES 15.2 OZ. 90W GEAR LUBE

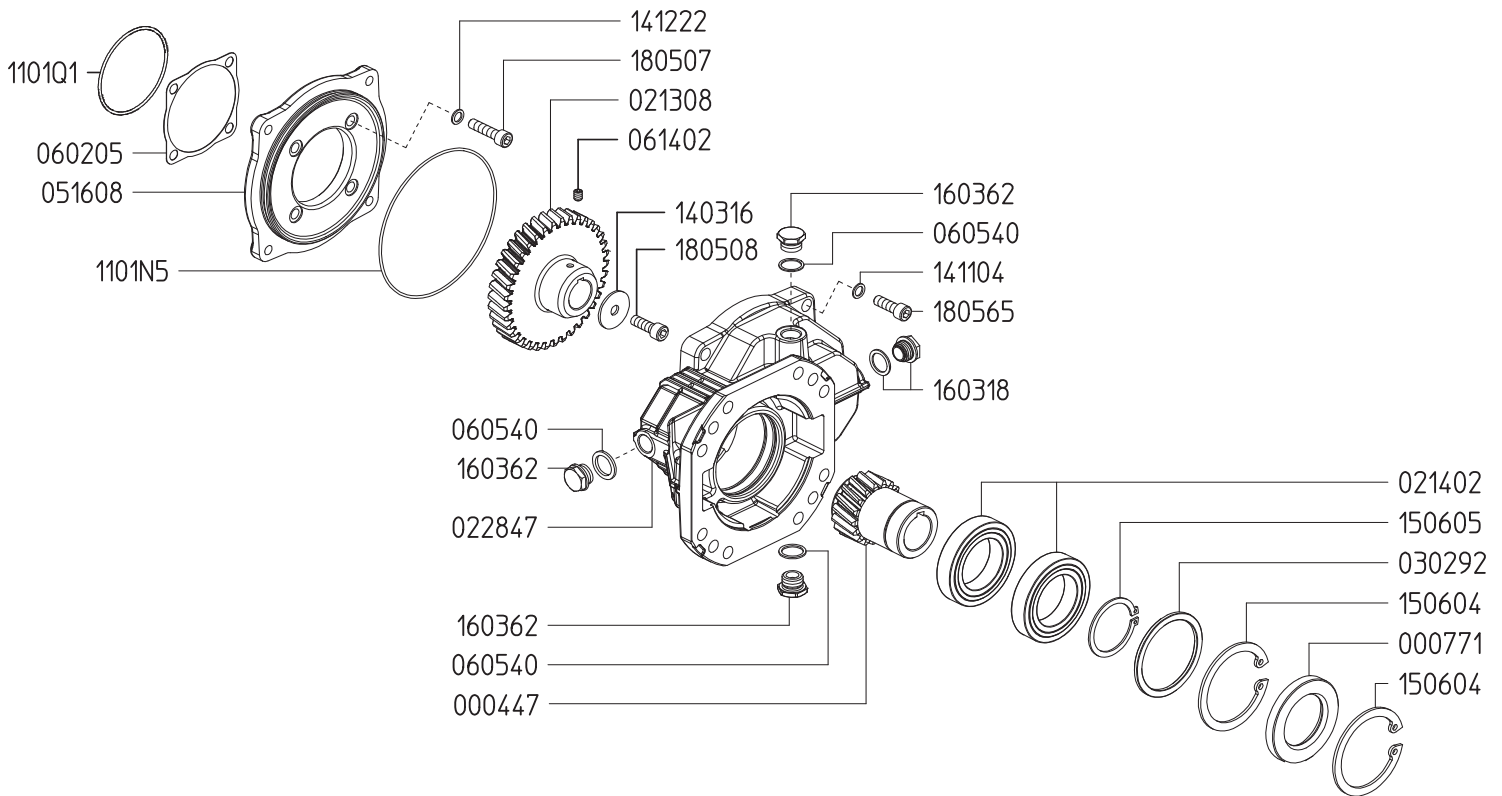

Revised 6-3-2021

Part #	Description	Qty	Part #	Description	Qty
0004.47	GEAR SHAFT "RC122" 1-1/8"	1	1101.N5	O-RING D158.42X2.62 (RIF.3625)	1
0007.71	OIL SEAL D55	1	1101.Q1	O-RING - MOUNTING FLANGE	1
0213.08	GEAR	1	1411.04	SERRATED WASHER D12	4
0214.02	BALL BEARING D55	2	1412.22	BONDED WASHER D10.7	4
0228.47	COUPLER	1	1506.04	SNAP RING D90	2
0302.92	SPACER	1	1506.05	SNAP RING D55	1
0516.08	FLANGE	1	1603.18	OIL PLUG G1/2 + GASKET	1
0602.05	GASKET	1	1603.62	PLUG G1/2	3
0605.40	GASKET	3	1805.07	ALLEN SCREW M10X40	4
0614.02	SET SCREW M8X10	1	1805.65	ALLEN SCREW M12X40	4

**GAS ENGINE GEAR REDUCTION FOR
NK-SERIES PLUNGER PUMPS**
on up to 40 HP B/S or HONDA GAS ENGINES with 1-7/16" SHAFTS
REQUIRES 15.2 OZ. 90W GEAR LUBE

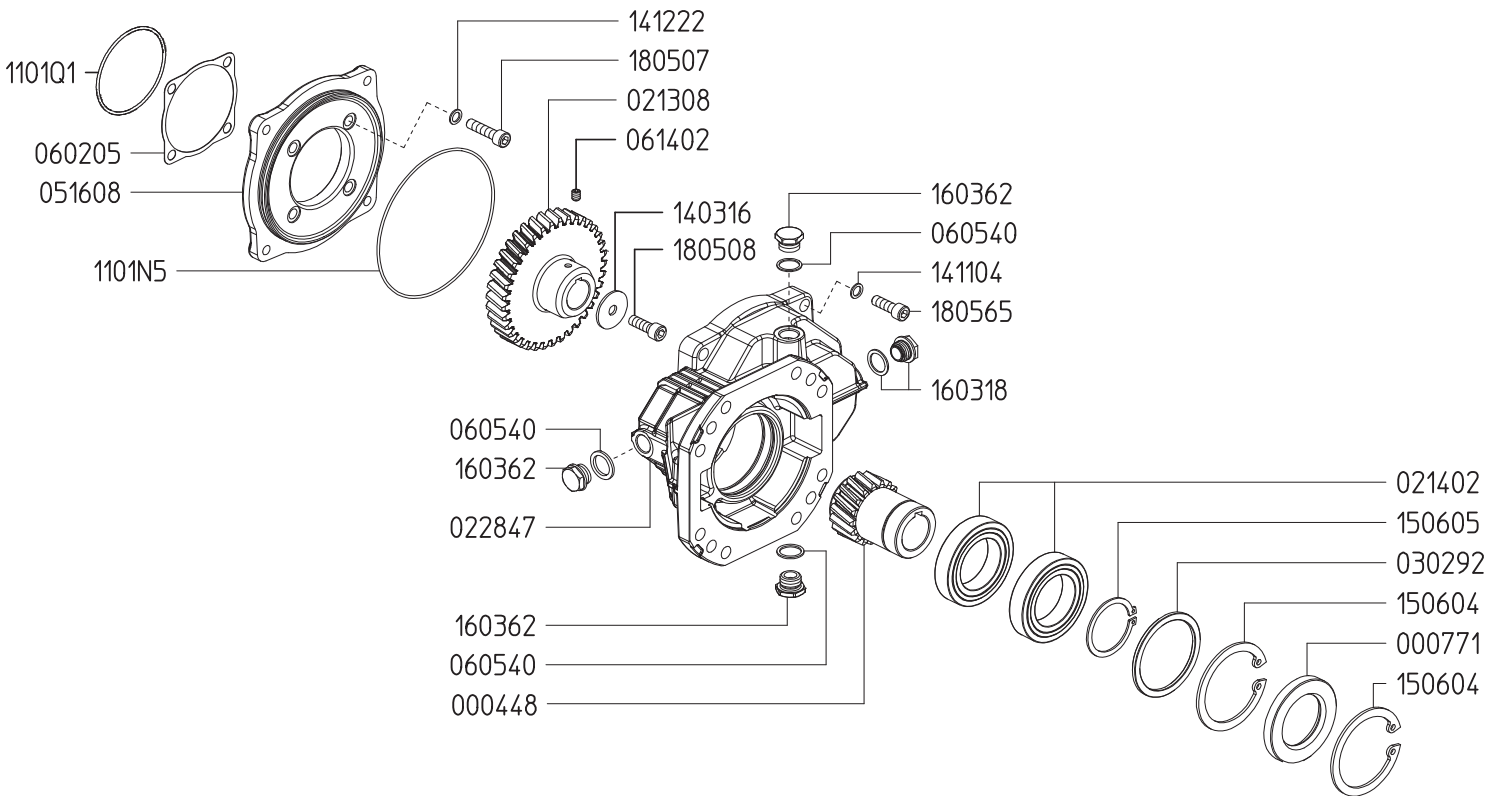

Revised 6-3-2021

Part #	Description	Qty	Part #	Description	Qty
0004.48	GEAR SHAFT "RC122" 1-7/16"	1	1101.N5	O-RING D158.42X2.62 (RIF.3625)	1
0007.71	OIL SEAL D55	1	1101.Q1	O-RING - MOUNTING FLANGE	1
0213.08	GEAR	1	1411.04	SERRATED WASHER D12	4
0214.02	BALL BEARING D55	2	1412.22	BONDED WASHER D10.7	4
0228.47	COUPLER	1	1506.04	SNAP RING D90	2
0302.92	SPACER	1	1506.05	SNAP RING D55	1
0516.08	FLANGE	1	1603.18	OIL PLUG G1/2 + GASKET	1
0602.05	GASKET	1	1603.62	PLUG G1/2	3
0605.40	GASKET	3	1805.07	ALLEN SCREW M10X40	4
0614.02	SET SCREW M8X10	1	1805.65	ALLEN SCREW M12X40	4

**GAS ENGINE GEAR REDUCTION FOR
NK-SERIES PLUNGER PUMPS**
on up to 40 HP KOHLER GAS ENGINES with 1-1/8" SHAFTS
REQUIRES 15.2 OZ. 90W GEAR LUBE

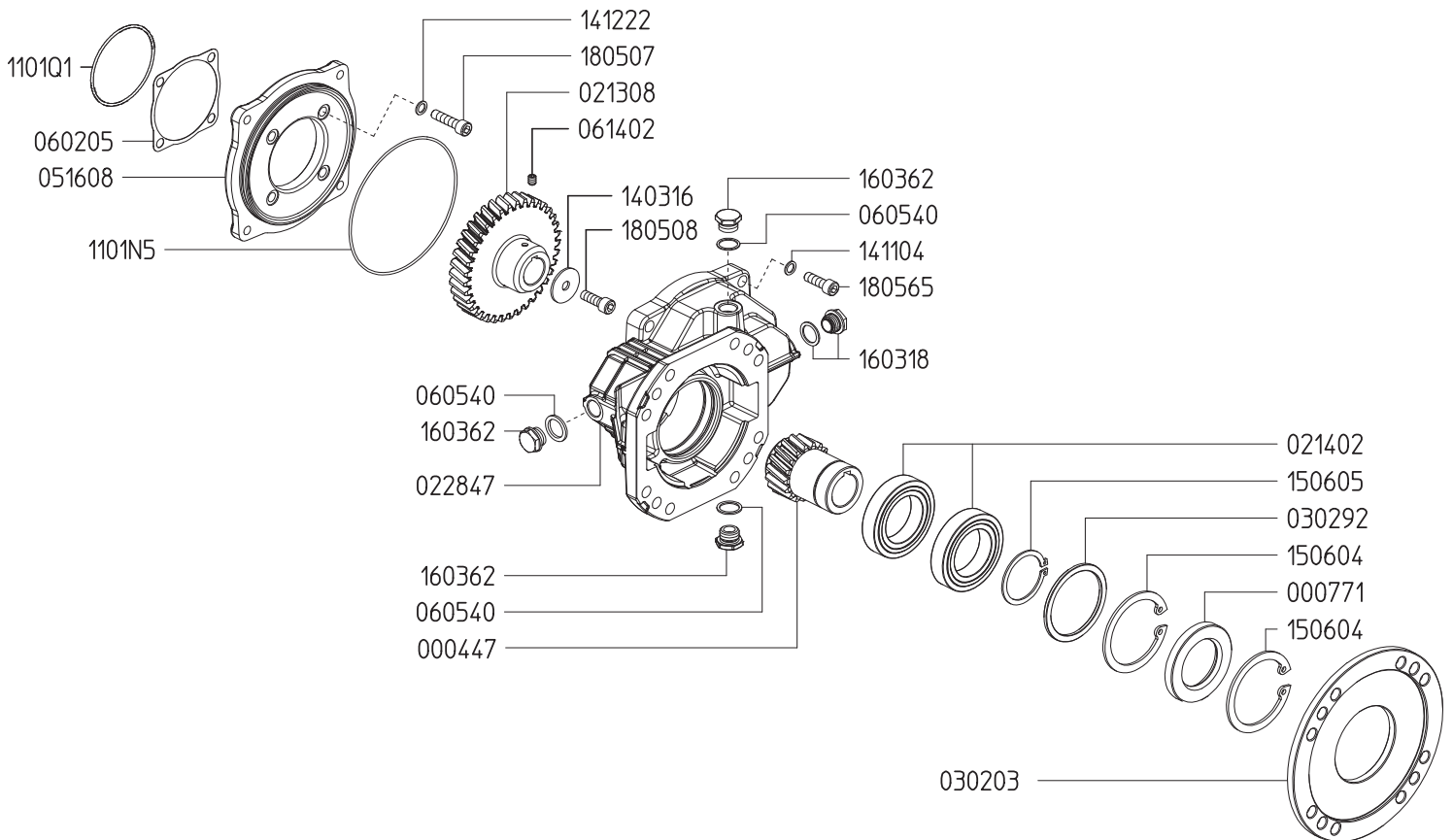

Revised 6-3-2021

Part #	Description	Qty	Part #	Description	Qty
0004.47	GEAR SHAFT "RC122" 1-1/8"	1	1101.N5	O-RING D158.42X2.62 (RIF.3625)	1
0007.71	OIL SEAL D55	1	1101.Q1	O-RING - MOUNTING FLANGE	1
0213.08	GEAR	1	1411.04	SERRATED WASHER D12	4
0214.02	BALL BEARING D55	2	1412.22	BONDED WASHER D10.7	4
0228.47	COUPLER	1	1506.04	SNAP RING D90	2
0302.03	SPACER - KOHLER ENGINE MOUNT	1	1506.05	SNAP RING D55	1
0302.92	SPACER	1	1603.18	OIL PLUG G1/2 + GASKET	1
0516.08	FLANGE	1	1603.62	PLUG G1/2	3
0602.05	GASKET	1	1805.07	ALLEN SCREW M10X40	4
0605.40	GASKET	3	1805.65	ALLEN SCREW M12X40	4
0614.02	SET SCREW M8X10	1			

**GAS ENGINE GEAR REDUCTION FOR
NK-SERIES PLUNGER PUMPS**
on up to 40 HP KOHLER GAS ENGINES with 1-7/16" SHAFTS
REQUIRES 15.2 OZ. 90W GEAR LUBE

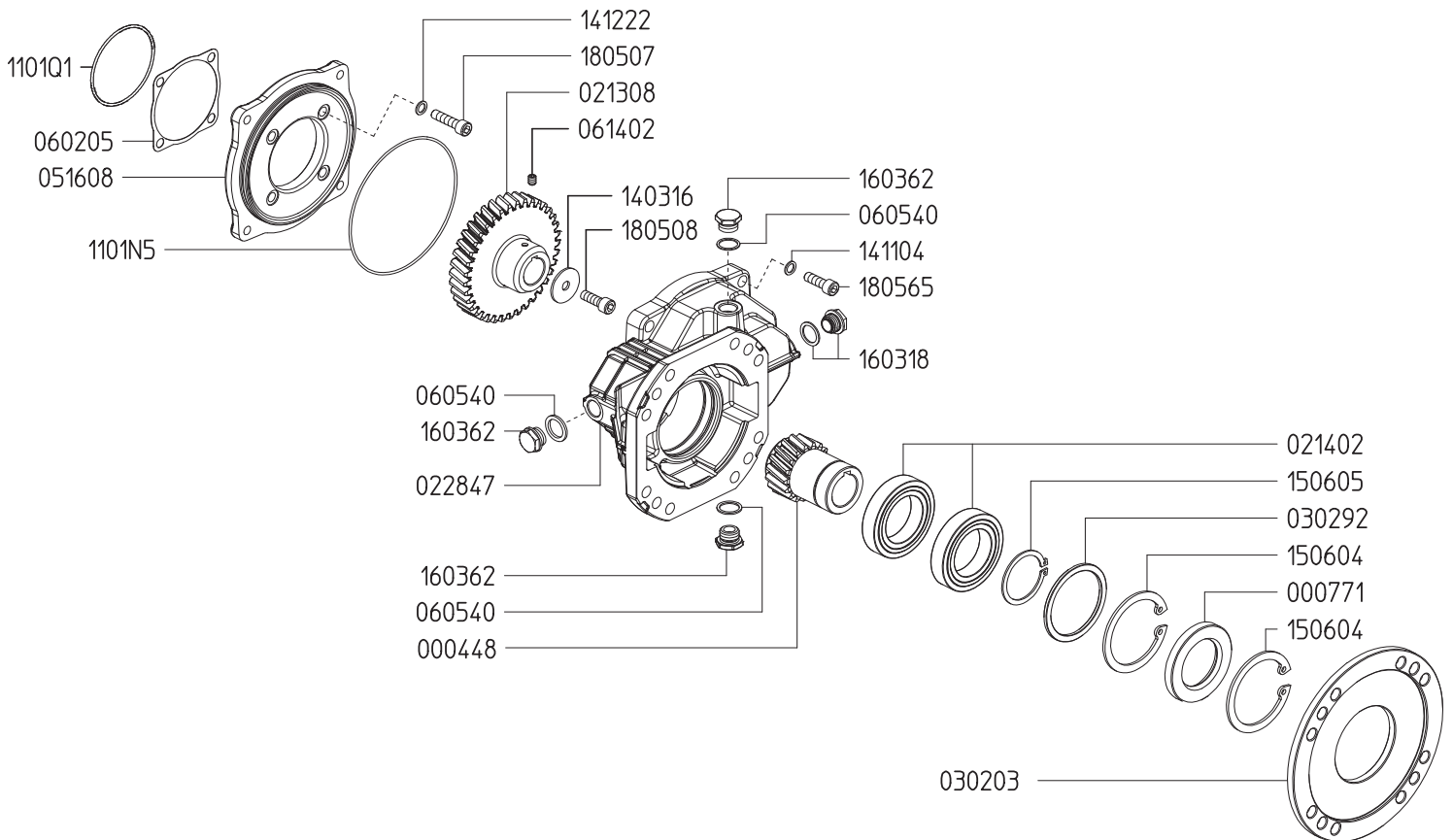

Revised 6-3-2021

Part #	Description	Qty	Part #	Description	Qty
0004.48	GEAR SHAFT "RC122" 1-7/16"	1	1101.N5	O-RING D158.42X2.62 (RIF.3625)	1
0007.71	OIL SEAL D55	1	1101.Q1	O-RING - MOUNTING FLANGE	1
0213.08	GEAR	1	1411.04	SERRATED WASHER D12	4
0214.02	BALL BEARING D55	2	1412.22	BONDED WASHER D10.7	4
0228.47	COUPLER	1	1506.04	SNAP RING D90	2
0302.03	SPACER - KOHLER ENGINE MOUNT	1	1506.05	SNAP RING D55	1
0302.92	SPACER	1	1603.18	OIL PLUG G1/2 + GASKET	1
0516.08	FLANGE	1	1603.62	PLUG G1/2	3
0602.05	GASKET	1	1805.07	ALLEN SCREW M10X40	4
0605.40	GASKET	3	1805.65	ALLEN SCREW M12X40	4
0614.02	SET SCREW M8X10	1			

*Dimensional Drawings are
Shown in Millimeters.
To Convert to Inches,
Multiply Dimension x 0.03937*

NK SERIES PUMPS 28mm & 30mm Plungers

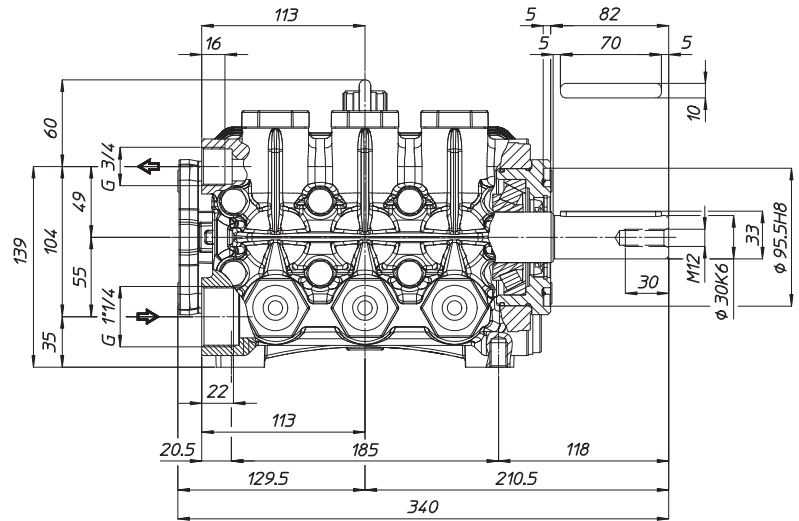
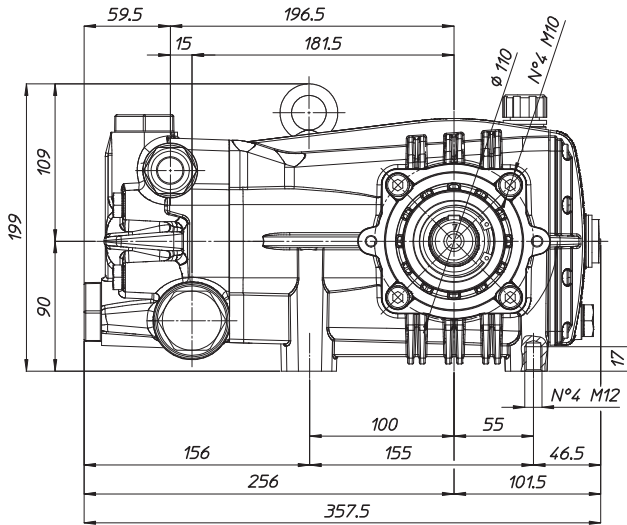

TORQUE SPECS

Ref.	Description	Ft./lb.	Nm	Loctite®
1	Head Bolts	37	50	-
2	Valve Caps	88	120	243
3	Inlet Cap	133	180	-
4	Outlet Cap	88	120	243
5	Bearing Flange Bolts	37	50	-
6	Rear Cover Bolts	8	11	-
7	Connecting Rod Bolts	19	25	243
8	Plunger Bolts	22	30	270
9	Valve Cover Bolts	-	-	-
10	Oil Drain Plug	8	11	-

