

## 3-Cylinder, Medium-Pressure Diaphragm Pumps

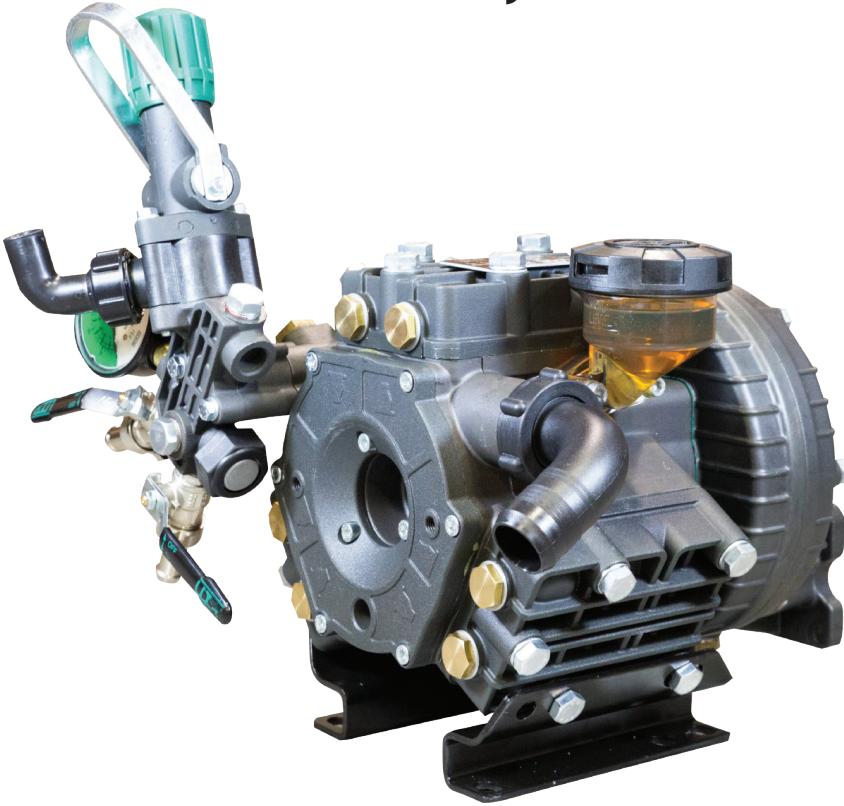

KAPPA 55 3-cylinder, medium pressure diaphragm pumps are internally manifolded with anodized aluminum construction and anodized aluminum and stainless steel liquid handling parts.

KAPPA 55 pumps are excellent choices for various horticultural, agricultural, lawn care, nursery, pest control and turf spraying applications. They are also effectively used for aircraft de-icing, hydrostatic testing and cleaning applications.

Model	GPM	l/min	PSI	bar	RPM	Drive Configuration	Weight
KAPPA 55 VA	15.0	57.0	560	38	550	Universal VA Drive Face. Mounting Rails	37 LBS
KAPPA 55 VAGR3/4	15.0	57.0	350	24	550	Gear Reduction for 3/4" Shaft Gas Engine, 4-6.5 HP	47 LBS
KAPPA 55 VAGR1	15.0	57.0	560	38	550	Gear Reduction for 1" Shaft Gas Engine, 8-20 HP	47 LBS
KAPPA 55 TSFVA	15.0	57.0	560	38	550	Universal VA Drive Face x 25 mm Solid Keyed Shaft	37 LBS

Specifications	KAPPA 55	Description	Part #
Inlet Port	1-1/4" Hose Barb	Diaphragm Kit (GREENTECH)	8700.26
Outlet Ports	(2) 1/2" Hose Barb	Diaphragm Bolt/Washer Kit	6062.48
Bypass	3/4" Hose Barb	Valve Kit	6062.46
Piston Diameter	55mm	Regulator Repair Kit	6062.55
Crankshaft Stroke/Code	15.0mm / T	Complete Repair Kit	8700.26CK
Dimensions	9.5"L x 12.5"W x 10.5"H		

**Lubrication:** Requires 23 oz. of Udor Lube 40W Premium Pump Oil.  
Alternate Oil: 30W non-detergent or 15W-40 non-detergent oil.



Maximum Flow	15.0 GPM / 57 lpm
Maximum Pressure	560 PSI / 38 bar
Maximum RPM	550 RPM
Inlet Port - Hose Barb	1-1/4" HB
Outlet Ports - Hose Barb, Valve	(2) 1/2" HB
Bypass - Hose Barb	3/4" HB
Dimensions	9.5" L x 12.5" W x 10.5" H
Weight	37 lbs

**Lubrication:** Requires 23 oz. of Udor Lube 40W Premium Pump Oil.  
Alternate Oil: 30W non-detergent or 15W-40 non-detergent oil.

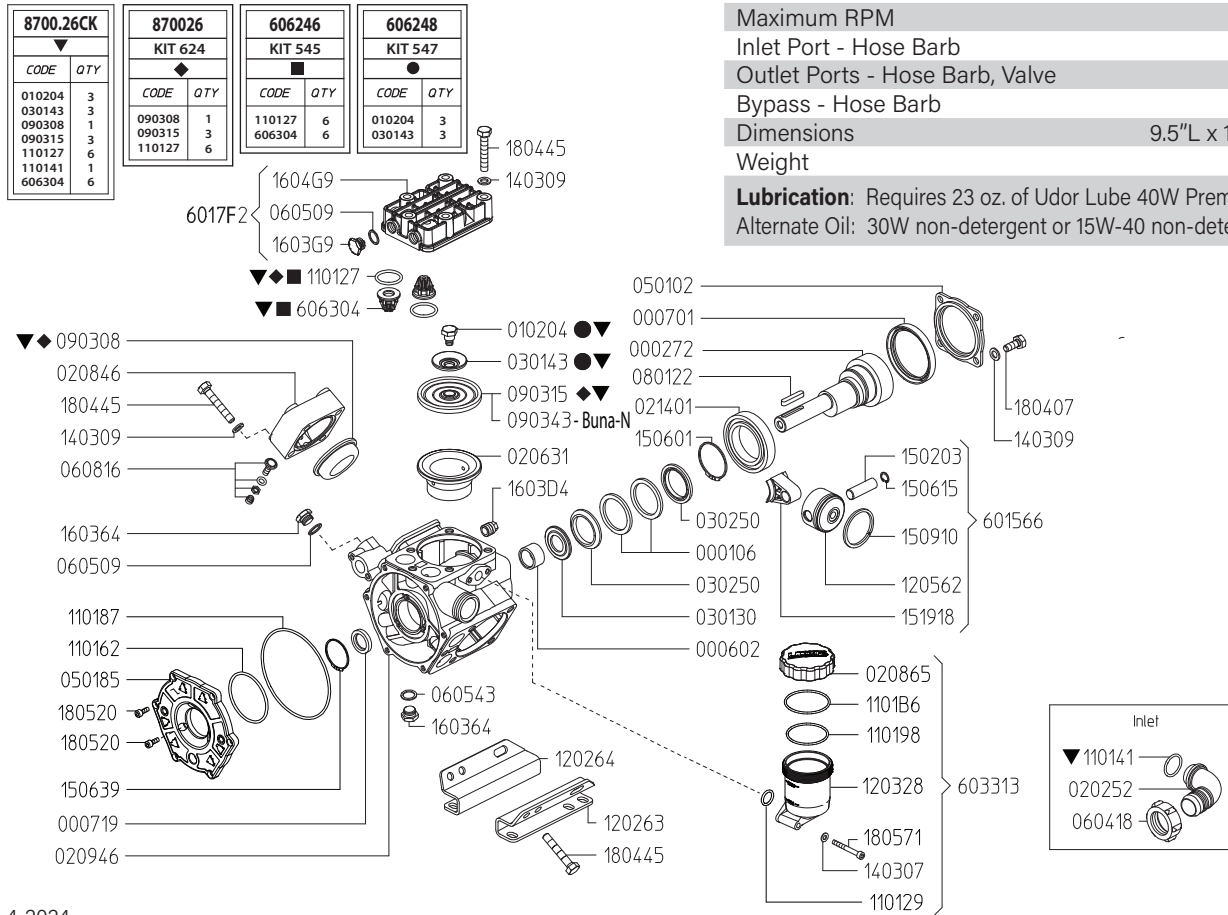

Revised 6-4-2024

Part #	Description	Qty	Part #	Description	Qty
0001.06	RETAINER RING	2	1202.63	RIGHT BASE PLATE	1
0002.72	SHAFT - TS VA	1	1202.64	LEFT BASE PLATE	1
0006.02	BUSHING D25	1	1203.28	OIL RESERVOIR	1
0007.01	OIL SEAL D78	1	1205.62	ALUMINIUM PISTON D55	3
0007.19	OIL SEAL D25	1	1403.07	WASHER D6.4	2
0102.04	DIAPHRAGM BOLT ■▼	3	1403.09	WASHER D10.5	19
0202.52	HOSE BARB D32	1	1502.03	PIN D15X48	3
0206.31	SLEEVE D55	3	1506.01	SNAP RING D60	1
0208.46	ACCUMULATOR COVER	1	1506.15	SNAP RING D15	3
0208.65	OIL RESERVOIR COVER	1	1506.39	SNAP RING	1
0209.46	CRANKCASE - TS	1	1509.10	PISTON RING D55	3
0214.01	BALL BEARING D60	1	1519.18	CONNECTING ROD	3
0301.30	BEARING DISC	1	1603.64	PLUG G3/8	2
0301.43	DIAPHRAGM DISC ■▼	3	1603.D4	PLUG G3/8	1
0302.50	ROD SPACER	2	1603.G9	PLUG G3/8	6
0501.02	FLANGE	1	1604.G9	HEAD	3
0501.85	CRANKCASE FLANGE	1	1804.07	HEX BOLT M10X25	4
0604.18	BARB NUT M42X2	1	1804.45	HEX BOLT M10X40	19
0605.09	GASKET D17	7	1805.20	ALLEN BOLT M6X16	9
0605.43	GASKET D17	1	1805.71	ALLEN BOLT M6X50	2
0608.16	AIR VALVE ASSEMBLY	1	6015.66	ROD ASSEMBLY D55	3
0801.22	KEY A8X7X45	1	6017.F2	HEAD ASSEMBLY	3
0903.08	ACCUMULATOR DIAPHRAGM ◆▼	1	6033.13	OIL RESERVOIR ASSEMBLY	1
0903.15	PISTON DIAPHRAGM D90 - GREENTECH ◆▼	3	6063.04	VALVE ASSEMBLY W/O O-RING ●▼	6
0903.43	PISTON DIAPHRAGM D90 - BUNA-N	3	6062.46	IN/OUTLET VALVE KIT (KIT 545)	1
1101.27	O-RING - VALVE ●◆▼	6	6062.48	DIAPHRGM BOLT/WASHER (KIT547)	1
1101.29	O-RING - OIL RESERVOIR	1	8700.26	DIAPHRAGM KIT - GREENTECH (KIT 624)	1
1101.41	O-RING - INLET HOSE BARB ▼	1	8700.26CK	COMPLETE REPAIR KIT	1
1101.62	O-RING - CRANKCASE FLANGE	1			
1101.87	O-RING - CRANKCASE FLANGE	1			
1101.98	O-RING - OIL RESERVOIR	1			
1101.B6	O-RING - OIL RESERVOIR	1			

- Parts in 6062.46 (Kit 545).
- Parts in 6062.48 (Kit 547).
- ◆ Parts in 8700.26 (Kit 624).
- ▼ Parts in 8700.26CK (Complete Repair Kit).

# 6010.24 & 6010.24/LP

## Pump Mounted Adjustable Pressure Regulators

606253		606255	
KIT 552		KIT 554	
Optional ▲		■	
CODE	QTY	CODE	QTY
090326	1	090326	1
110104	1	110104	1
110112	2	110106	2
110141	1	110112	2
120419	1	110141	1
150123	1	150123	1
181001	1	870104	1

### By-Pass

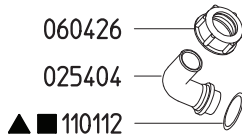

### Optional Straight Barb



### Outlet

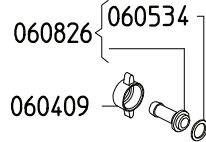

6010.24	Maximum Flow	27.0 GPM / 102 lpm
	Maximum Pressure	560 PSI / 38 bar
6010.24/LP	Maximum Flow	27.0 GPM / 102 lpm
	Maximum Pressure	350 PSI / 24 bar
	Inlet Port - Hose Barb	-
	Outlet Ports - Hose Barb, Valve	(2) 1/2" HB
	Bypass - Hose Barb	3/4" HB

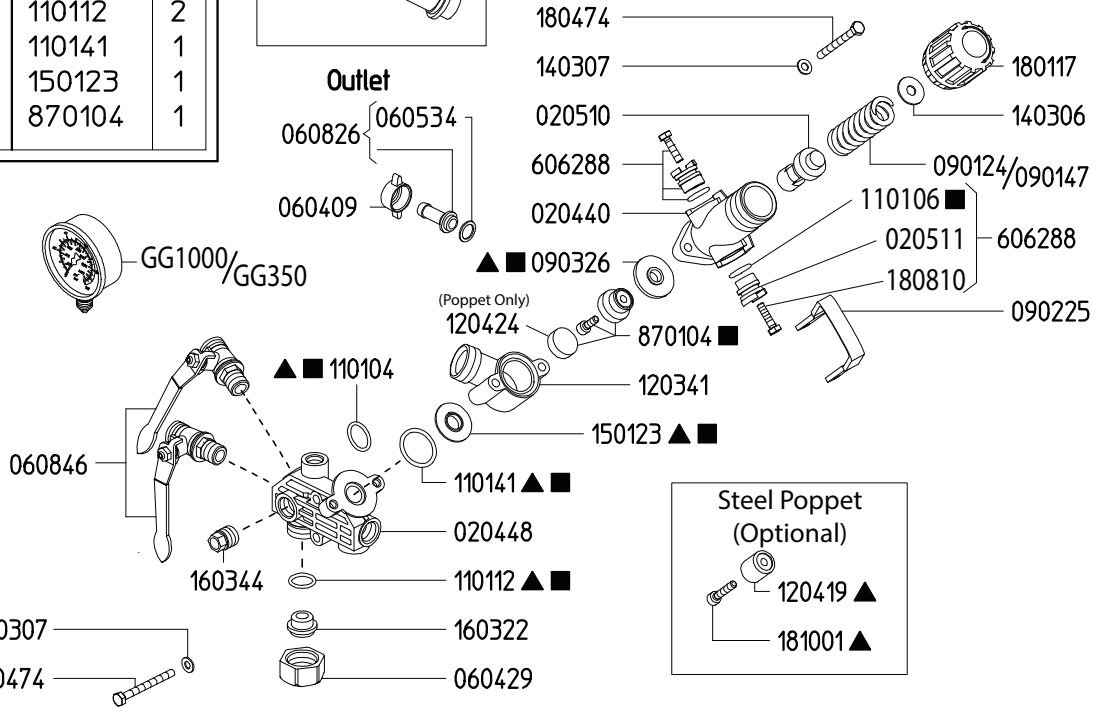

Revised 6-4-2024

Part #	Description	Qty
0202.25	BYPASS HOSE BARB - STRAIGHT (OPTIONAL)	1
0204.40	VALVE BODY	1
0204.48	MAIN BODY	1
0205.10	VALVE CYLINDER	1
0205.11	VALVE CYLINDER CAM	2
0254.04	BYPASS HOSE BARB - ELBOW	1
0604.09	DISCHARGE BARB NUT	2
0604.26	BYPASS BARB NUT	1
0604.29	BARB NUT	1
0605.34	GASKET	2
0608.26	1/2" HOSE BARB W/GASKET	2
0608.46	BALL VALVE; LEFT	2
0901.24	HIGH PRESSURE SPRING "6010.24"	1
0901.47	LOW PRESSURE SPRING "6010.24/LP"	1
0902.25	DUMP VALVE LEVER	1
0903.26	DIAPHRAGM ▲■	1
1101.04	O-RING ▲■	1
1101.06	O-RING ■	2
1101.12	O-RING ▲■	2
1101.41	O-RING ▲■	1

Part #	Description	Qty
1203.41	BODY	1
1204.19	STEEL POPPET - OPTIONAL ▲	1
1204.24	URETHANE POPPET ONLY	1
1403.06	WASHER	1
1403.07	WASHER	4
1501.23	SEAT ▲■	1
1603.22	PLUG	1
1603.44	PLUG	2
1801.17	ADJUSTMENT KNOB	1
1804.74	BOLT	4
1808.10	BOLT	2
1810.01	STAINLESS STEEL BOLT - OPTIONAL ▲	1
6062.88	REGULATOR CAM KIT	2
8701.04	URETHANE POPPET ASSEMBLY ■	1
GG1000	HIGH PRESSURE GAUGE - 1000 PSI "6010.24"	1
GG350	LOW PRESSURE GAUGE - 350 PSI "6010.24/LP"	1
6062.53	REPAIR KIT - STEEL POPPET (KIT 552) OPTIONAL	1
6062.55	REPAIR KIT - 6010.24/LP (KIT 554)	1

▲ Parts Included in Repair Kit 6062.53 (KIT 552)

■ Parts Included in Repair Kit 6062.55 (KIT 554)

- Before operating or re-operating the pump, push the manual dump valve lever (0902.25) down, so the pump will start at zero pressure. FAILURE TO DO SO WILL VOID PUMP WARRANTY.
- Turn pressure adjustment knob (1801.17) counterclockwise to relieve spring tension. NOTE: Step 2 applies only to initial start-up, and is not necessary in daily operation of pump.
- Start unit and let run until air is evacuated from system, when only liquid is expelled from the bypass line.
- Return dump valve lever to the UP position. Open spray gun or spray boom and turn the pressure adjustment knob (1801.17) clockwise until desired operating pressure is achieved.

# KAPPA 55 DIMENSIONS

All Dimensions are WITHOUT Control Unit or Regulator

Dimensional Drawings are Shown in Millimeters. To Convert to Inches, Multiply Dimension x 0.03937

## Specifications

## KAPPA 55

Inlet Port - Hose Barb	1-1/4"HB
Outlet Ports - Hose Barb	(2) 1/2"HB
Bypass - Hose Barb	3/4" HB
Dimensions	9.5"L x 12.5"W x 10.5"H
Diaphragm Material	GREENTECH (Std) Buna-N (Opt)

**Lubrication:** Requires 23 oz. of Udor Lube 40W Premium Pump Oil. Alternate Oil: 30W non-detergent or 15W-40 non-detergent oil.

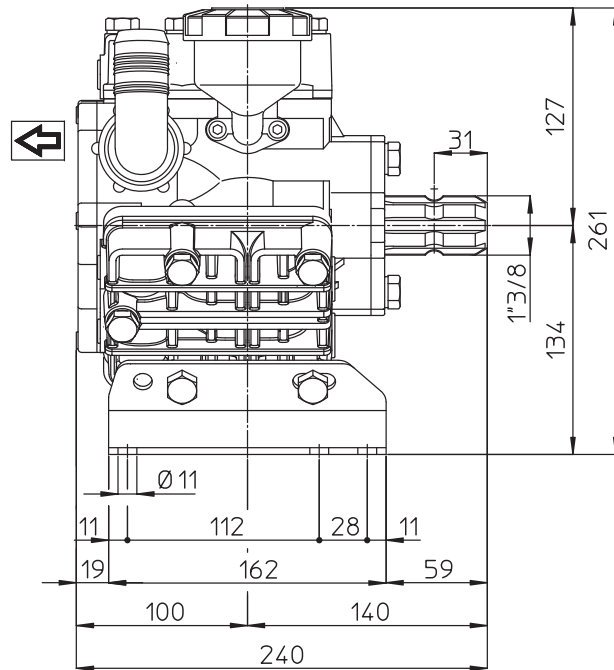
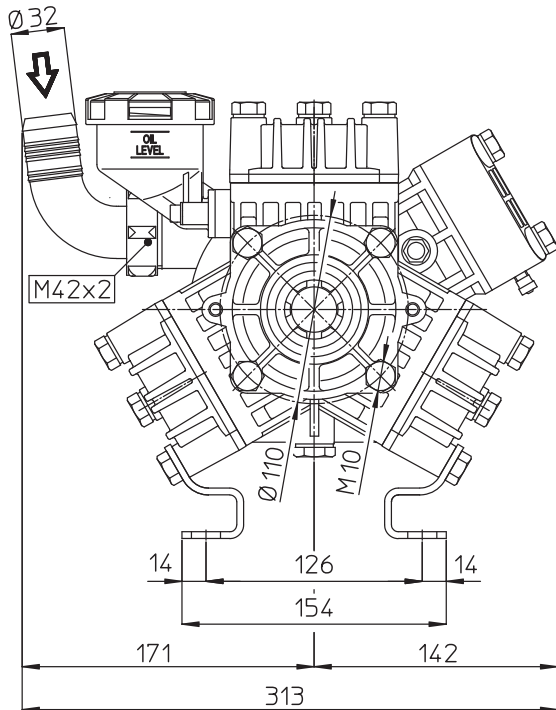

## TORQUE SPECS

Ref.	Description	Ft./lb.	Nm
1	Diaphragm Bolts (Use Loctite 243)	18	25
2	Head Bolts	30	40
3	Pulsation Dampener Bolts	30	40
4	Inlet Flange Bolts	7	10
5	Bearing Flange Bolts	25	34
6	Oil Cup Bolts	6	8
7	Valve Cover Bolts	N/A	N/A

