

## 3-Cylinder, Medium-Pressure Diaphragm Pumps

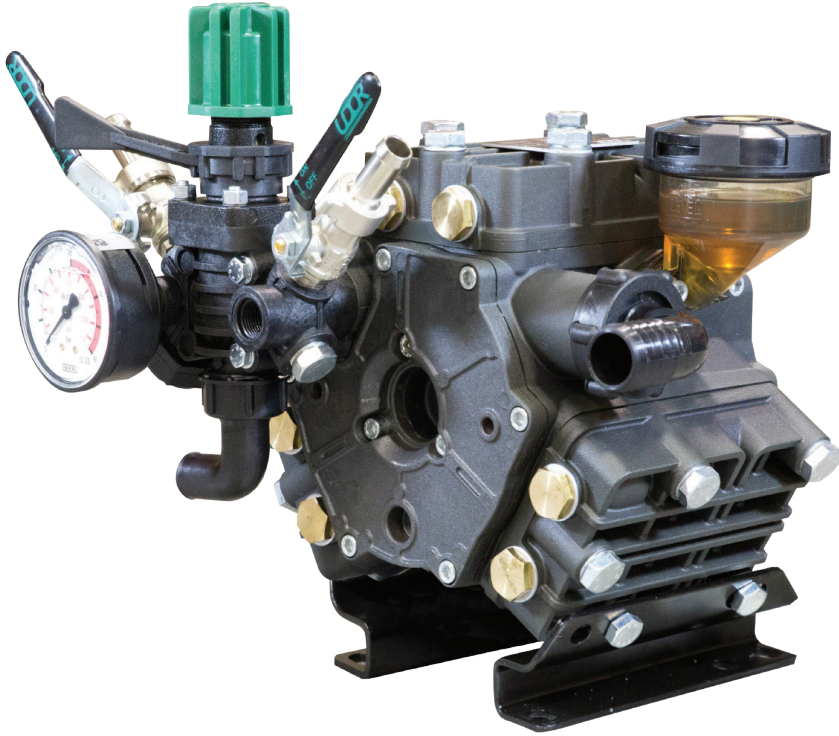

KAPPA 43 3-cylinder, medium pressure diaphragm pumps are internally manifolded with anodized aluminum construction and anodized aluminum and stainless steel liquid handling parts.

KAPPA 43 pumps are excellent choices for various horticultural, agricultural, lawn care, nursery, pest control and turf spraying applications. They are also effectively used for aircraft de-icing, hydrostatic testing and cleaning applications.

Model	GPM	l/min	PSI	bar	RPM	Drive Configuration	Weight
KAPPA 43	10.5	40.0	560	38	550	25 mm Solid Keyed Shaft. Mounting Rails	29 LBS
KAPPA 43 GR3/4LP	10.5	40.0	350	24	550	Gear Reduction for 3/4" Shaft Gas Engine, 4-6.5 HP	39 LBS
KAPPA 43 GR3/4	10.5	40.0	560	38	550	Gear Reduction for 3/4" Shaft Gas Engine, 4-6.5 HP	39 LBS

Specifications	KAPPA 43	Description	Part #
Inlet Port	1" Hose Barb	Diaphragm Kit (GREENTECH)	8700.45
Outlet Ports	(2) 1/2" Hose Barb	Diaphragm Bolt/Washer Kit	6062.48
Bypass	3/4" Hose Barb	Valve Kit	6062.46
Piston Diameter	55mm	Regulator Repair Kit	6062.A9
Crankshaft Stroke/Code	12.0mm / S	Complete Repair Kit	8700.45CK
Dimensions	9.5"L x 11.5"W x 10.0"H		

**Lubrication:** Requires 20 oz. of Udor Lube 40W Premium Pump Oil.  
Alternate Oil: 30W non-detergent or 15W-40 non-detergent oil.



Maximum Flow	10.5 GPM / 40 lpm
Maximum Pressure	560 PSI / 38 bar
Maximum RPM	550 RPM
Inlet Port - Hose Barb	1" HB
Outlet Ports - Hose Barb, Valve	(2) 1/2" HB
Bypass - Hose Barb	3/4" HB
Dimensions	9.5"L x 11.5"W x 10.0"H
Weight	29 lbs

**Lubrication:** Requires 20 oz. of Udor Lube 40W Premium Pump Oil.  
Alternate Oil: 30W non-detergent or 15W-40 non-detergent oil.

870045 KIT 634		6062A2 KIT 601		606246 KIT 545		606248 KIT 547		8700.45CK	
CODE	QTY	CODE	QTY	CODE	QTY	CODE	QTY	CODE	QTY
090315	3	090343	3	110127	6	010204	3	010204	3
110127	6	110127	6	606304	6	030143	3	030143	3
								110141	1
								110127	6
								606304	6

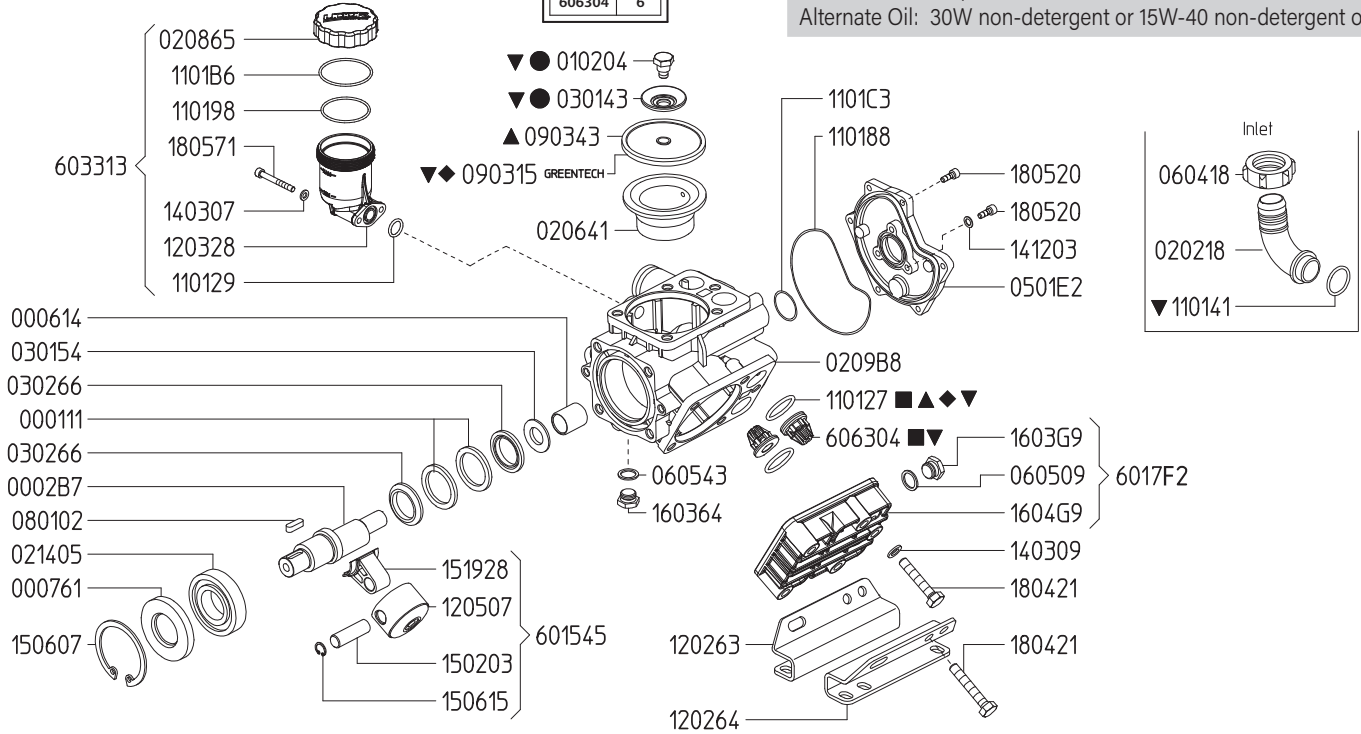

Revised 6-4-2024

Part #	Description	Qty	Part #	Description	Qty
0001.11	RETAINER RING	2	1203.28	OIL RESERVOIR	1
0002.B7	SHAFT - GR	1	1205.07	ALUMINIUM PISTON D55	3
0006.14	BUSHING D20	1	1403.07	WASHER D6.4	2
0007.61	OIL SEAL D35	1	1403.09	WASHER D10.5	11
0102.04	DIAPHRAGM BOLT ●▼	3	1412.03	BONDED WASHER D6.7	3
0202.18	HOSE BARB D25 ( 1" )	1	1502.03	PIN D15X48	3
0206.41	SLEEVE D55	3	1506.07	SNAP RING D72	1
0208.65	OIL RESERVOIR COVER	1	1506.15	SNAP RING D15	3
0209.B8	CRANKCASE	1	1519.28	CONNECTING ROD	3
0214.05	BALL BEARING D35	1	1603.64	PLUG G3/8	1
0301.43	DIAPHRAGM DISC ●▼	3	1603.G9	PLUG G3/8	6
0301.54	BEARING DISC	1	1604.G9	HEAD	3
0302.66	ROD SPACER	2	1804.21	HEX BOLT M10X55	15
0501.E2	CRANKCASE FLANGE	1	1805.20	ALLEN BOLT M6X16	9
0604.18	BARB NUT M42X2	1	1805.71	ALLEN BOLT M6X50	2
0605.09	GASKET D17	6	6015.45	ROD ASSEMBLY D55	3
0605.43	GASKET D17	1	6017.F2	HEAD ASSEMBLY	3
0801.02	KEY A8X7X25	1	6033.13	OIL RESERVOIR ASSEMBLY	1
0903.15	PISTON DIAPHRAGM D90 - GREENTECH ◆▼	3	6063.04	VALVE ASSEMBLY W/O O-RING ●▼	6
0903.43	PISTON DIAPHRAGM D90 - BUNA ▲	3	6062.46	IN/OUTLET VALVE KIT (KIT 545)	1
1101.27	O-RING - VALVE ◆▲◆▼	6	6062.48	DIAPHRAGM BOLT/WASHER (KIT 547)	1
1101.29	O-RING - OIL RESERVOIR	1	6062.A2	DIAPHRAGM KIT - BUNA-N (KIT 601)	1
1101.41	O-RING - INLET HOSE BARB ▼	1	8700.45	DIAPHRAGM KIT - GREENTECH (KIT 634)	1
1101.88	O-RING - CRANKCASE FLANGE	1	8700.45CK	COMPLETE REPAIR KIT	1
1101.98	O-RING - OIL RESERVOIR	1			
1101.B6	O-RING - OIL RESERVOIR	1			
1101.C3	O-RING - CRANKCASE FLANGE	1			
1202.63	RIGHT BASE PLATE	1			
1202.64	LEFT BASE PLATE	1			

- Parts in 6062.46 (Kit 545).
- Parts in 6062.48 (Kit 547).
- ▲ Parts in 6062.A2 (Kit 601).
- ◆ Parts in 8700.45 (Kit 634).
- ▼ Parts in 8700.45CK (Complete Repair Kit).

## Adjustable Pressure Regulator

Maximum Flow	27.0 GPM / 102 lpm
Maximum Pressure	560 PSI / 38 bar
Inlet Port - Hose Barb	-
Outlet Ports - Hose Barb, Valve	(2) 1/2" HB
Bypass - Hose Barb	3/4" HB

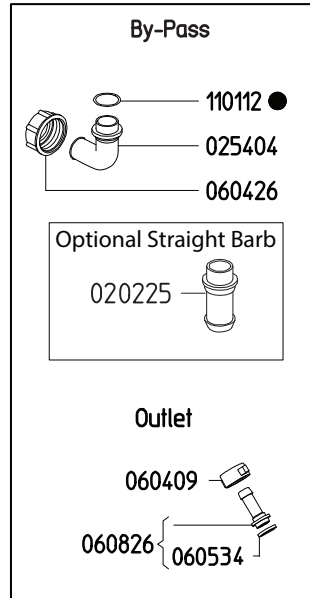
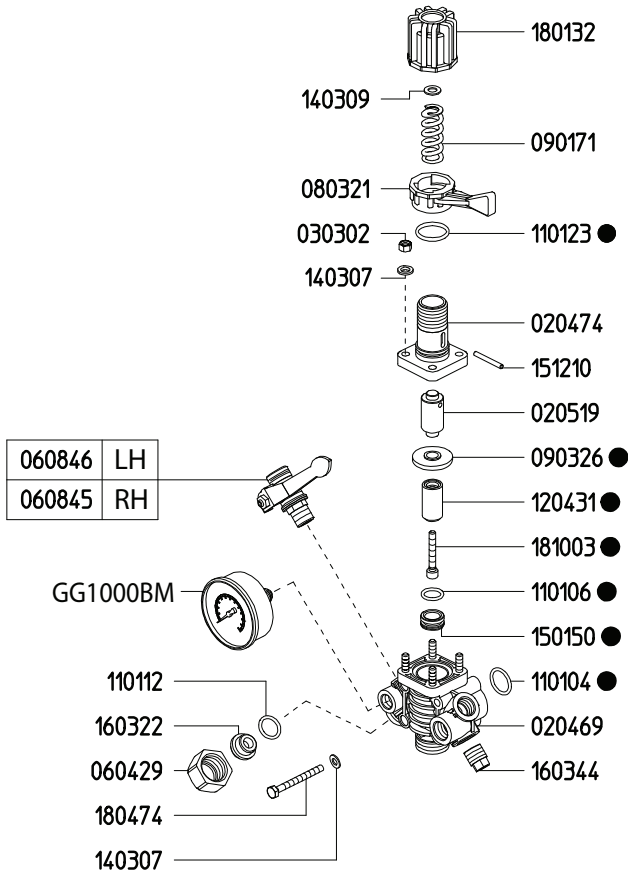

<b>6062A9</b>	
<b>KIT 608</b>	
●	
CODE	QTY
090326	1
110104	1
110106	1
110112	1
110123	1
120431	1
150150	1
181003	1

Revised 6-4-2024

Part #	Description	Qty
0202.25	BYPASS HOSE BARB - STRAIGHT (OPTIONAL)	1
0204.69	BODY	1
0204.70	BODY	1
0205.19	CYLINDER	1
0254.04	BYPASS HOSE BARB - ELBOW	1
0303.02	NUT	4
0604.09	BARB NUT	2
0604.26	BYPASS BARB NUT	1
0604.29	NUT	1
0605.34	GASKET	2
0608.26	1/2" HOSE BARB W/GASKET	2
0608.45	BALL VALVE - RIGHT	1
0608.46	BALL VALVE - LEFT	1
0803.21	LEVER	1
0901.71	SPRING (HP 560 PSI)	1
0903.26	DIAPHRAGM ●	1
1101.04	O-RING ●	1

Part #	Description	Qty
1101.06	O-RING ●	1
1101.12	O-RING ●	2
1101.23	O-RING ●	1
1204.31	POPPET ●	1
1403.07	WASHER	6
1501.50	SEAT ●	1
1512.10	PIN	1
1603.22	PLUG	1
1603.44	PLUG	1
1801.32	ADJUSTMENT KNOB	1
1804.74	BOLT	2
1810.03	STAINLESS STEEL BOLT ●	1
6062.A9	REPAIR KIT FOR 6010.9X CONTROL UNIT (KIT 608)	1
GG1000BM	PRESSURE GAUGE - 1000 PSI BACK MOUNT	1

● Parts Included in Repair Kit #6062.A9 (KIT 608)

The control unit features a manual dump valve, pressure control knob, glycerine filled pressure gauge, and two ball valve discharge ports.

1. Before operating or re-operating the pump move lever (0803.21) to the dump position (Right) so the pump will start at zero pressure. (Failure to do so will void the pump warranty.)
2. Turn pressure adjustment knob (1801.32) counter clockwise to relieve spring tension. This step only applies to the initial start up and is not necessary in daily operation of pump.
3. Start unit and let run until air is evacuated from the system.
4. Move lever (0803.21) to the pressure position (Left) open spray gun or spray boom and turn the pressure adjustment knob (1801.32) clockwise until desired operating pressure is achieved.

# KAPPA 43 DIMENSIONS

All Dimensions are WITHOUT Control Unit or Regulator

Dimensional Drawings are Shown in Millimeters. To Convert to Inches, Multiply Dimension x 0.03937

## Specifications

## KAPPA 43

Inlet Port - Hose Barb	1" HB
Outlet Ports - Hose Barb	(2) 1/2" HB
Bypass - Hose Barb	3/4" HB
Dimensions	9.5"L x 11.5"W x 10.0"H
Diaphragm Material	GREENTECH (Std) Buna-N (Opt)

**Lubrication:** Requires 20 oz. of Udor Lube 40W Premium Pump Oil.  
Alternate Oil: 30W non-detergent or 15W-40 non-detergent oil.

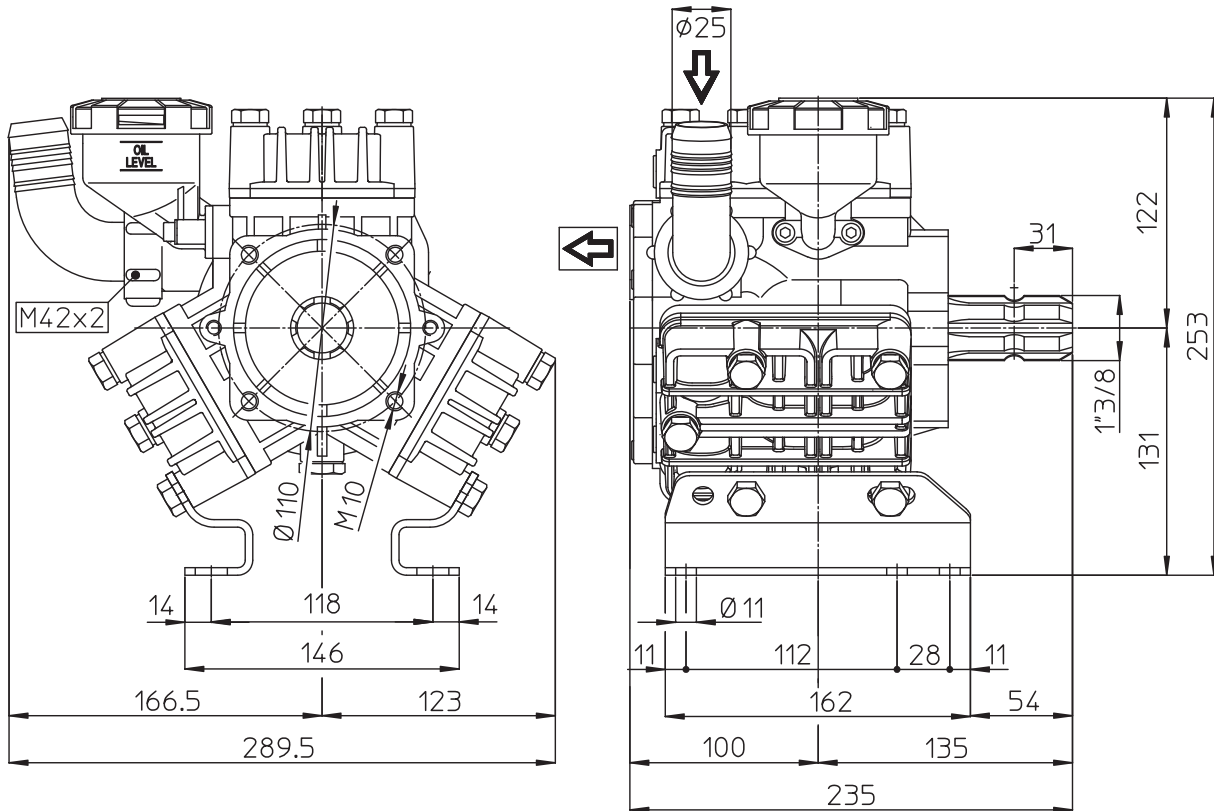

## TORQUE SPECS

Ref.	Description	Ft./lb.	Nm
1	Diaphragm Bolts (Use Loctite 243)	18	25
2	Head Bolts	30	40
3	Pulsation Dampener Bolts	-	-
4	Inlet Flange Bolts	7	10
5	Bearing Flange Bolts	-	-
6	Oil Cup Bolts	6	8
7	Valve Cover Bolts	-	-

