

## 2-Cylinder, Medium-Pressure Diaphragm Pumps

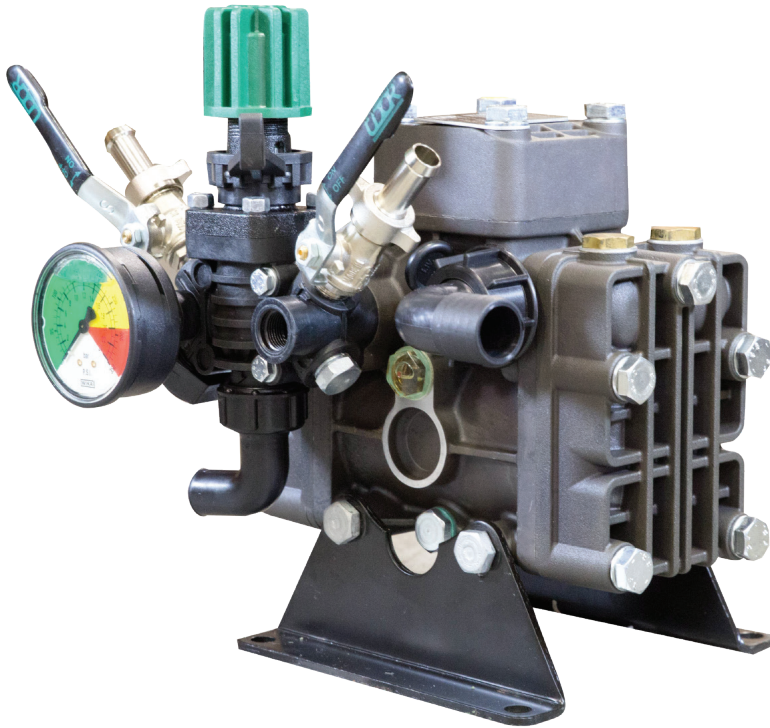

**KAPPA 25** 2-cylinder, medium pressure diaphragm pumps are internally manifolded with anodized aluminum construction and anodized aluminum and stainless steel liquid handling parts.

**KAPPA 25** pumps are excellent choices for various horticultural, agricultural, lawn care, nursery, pest control and turf spraying applications. They are also effectively used for aircraft de-icing, hydrostatic testing and cleaning applications.

Model	GPM	l/min	PSI	bar	RPM	Drive Configuration	Weight
<b>KAPPA 25</b>	7.0	26.5	350	24	550	25 mm Solid Keyed Shaft. Mounting Rails	18 LBS
<b>KAPPA 25 GR3/4</b>	7.0	26.5	350	24	550	Gear Reduction for 3/4" Shaft Gas Engine, 4-6.5 HP	28 LBS

Specifications	KAPPA-25
Inlet Port	1" Hose Barb
Outlet Ports	(2) 1/2" Hose Barb
Bypass	3/4" Hose Barb
Piston Diameter	55mm
Crankshaft Stroke/Code	10.0mm / I
Dimensions	8.5"L x 9.0"W x 9.5"H

**Lubrication:** Requires 12 oz. of Udor Lube 40W Premium Pump Oil.  
Alternate Oil: 30W non-detergent or 15W-40 non-detergent oil.

Description	Part #
Diaphragm Kit (GREENTECH)	6062.C1
Diaphragm Bolt/Washer Kit	6062.B4
Valve Kit	6062.42
Regulator Repair Kit	6062.A9
Complete Repair Kit	8700.65CK



Maximum Flow	7.0 GPM / 26.5 lpm
Maximum Pressure	350 PSI / 24 bar
Maximum RPM	550 RPM
Inlet Port - Hose Barb	1" HB
Outlet Ports - Hose Barb, Valve	(2) 1/2" HB
Bypass - Hose Barb	3/4" HB
Dimensions - Pump Only	8.5"L x 9.0"W x 9.5"H
Weight - with GR	28 lbs

**Lubrication:** Requires 12 oz. of Udor Lube 40W Premium Pump Oil.  
Alternate Oil: 30W non-detergent or 15W-40 non-detergent oil.

6062C1 KIT 618		6062B5 KIT 613		6062A2 KIT 541		6062B4 KIT 612		8700.65CK	
CODE	QTY	CODE	QTY	CODE	QTY	CODE	QTY	CODE	QTY
090308	1	090308	1	110127	4	010204	2	010204	2
090315	2	090343	2	606304	4	030143	2	030143	2
110127	4	110127	4					010204	2
								030143	2
								090308	1
								090315	2
								110104	1
								110127	4
								606304	4

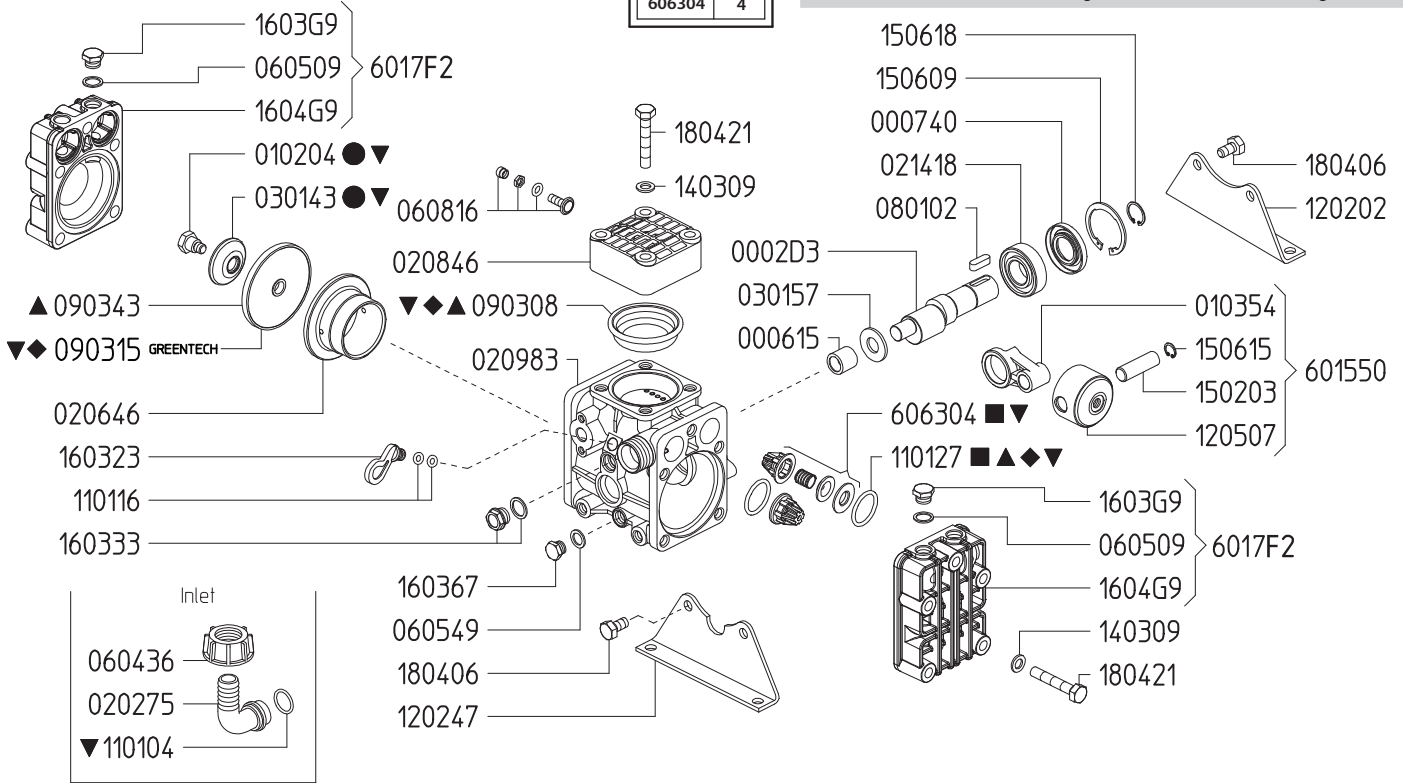

Revised 1-21-2022

Part #	Description	Qty	Part #	Description	Qty
0002.D3	SHAFT "KAPPA 25" GR	1	1502.03	PIN D15X48	2
0006.15	BUSHING D16	1	1506.09	SNAP RING D52	1
0007.40	OIL SEAL D45	1	1506.15	SNAP RING D15	2
0102.04	DIAPHRAGM BOLT "DELTA/ZETA" ●▼	2	1506.18	SNAP RING D25	1
0103.54	CONNECTING ROD "KAPPA 25/32"	2	1603.23	OIL PLUG	1
0202.75	HOSE BARB D25	1	1603.33	PLUG G3/8+GASKET	1
0206.46	SLEEVE D55 "KAPPA 25"	2	1603.67	PLUG G1/4	1
0214.18	BALL BEARING D25	1	1603.G9	PLUG G3/8	4
0301.43	DIAPHRAGM DISC "KAPPA 25/33/55/ZETA" ●▼	2	1604.G9	HEAD "KAPPA 25/33/55"	2
0301.57	SPACER "KAPPA 15"	1	1804.06	HEX BOLT M8X40	4
0604.36	BARB NUT G1"	1	1804.21	HEX BOLT M10X55	10
0605.09	GASKET D17	4	6015.50	ROD ASSY "KAPPA 25/32" D55	2
0605.49	GASKET D13	1	6017.F2	HEAD ASSEMBLY	2
0801.02	KEY A8X7X25 UNI6604-69	1	6063.04	VALVE ASSEMBLY W/O O-RING ■▼	4
0903.08	ACCUMULATOR DIAPHRAGM ◆▲▼	1	6062.42	IN/OUTLET VALVE KIT "KAPPA 25" (KIT 541)	1
0903.15	PISTON DIAPHRAGM D90 - GREENTECH ◆▼	2	6062.B4	DIAPHRAGM DISC "KAPPA 25/32" (KIT 612)	1
0903.43	PISTON DIAPHRAGM D90 - BUNA ▲	2	6062.B5	DIAPHRAGM KIT - BUNA (KIT 613)	1
1101.04	O-RING - INLET HOSE BARB ▼	1	6062.C1	DIAPHRAGM KIT - GREENTECH (KIT 618)	1
1101.16	O-RING - OIL PLUG	2	8700.65CK	COMPLETE REPAIR KIT	1
1101.27	O-RING - VALVE ◆▲■▼	4		■ Parts in 6062.42 (Kit 541).	
1202.02	BASE PLATE "KAPPA 25/32/DELTA 40/50"	1		● Parts in 6062.B4 (Kit 612).	
1202.47	BASE PLATE "KAPPA 25/32"	1		▲ Parts in 6062.B5 (Kit 613).	
1205.07	ALUMINIUM PISTON D55 "KAPPA 25/DELTA 40"	2		◆ Parts in 6062.C1 (Kit 618).	
1403.09	WASHER D10.5	10		▼ Parts in 8700.65CK (Complete Repair Kit).	

**GAS ENGINE GEAR REDUCTION FOR  
KAPPA 25 DIAPHRAGM PUMPS  
on GAS ENGINES with 3/4" SHAFTS**  
REQUIRES 3 OZ. 90W GEAR LUBE

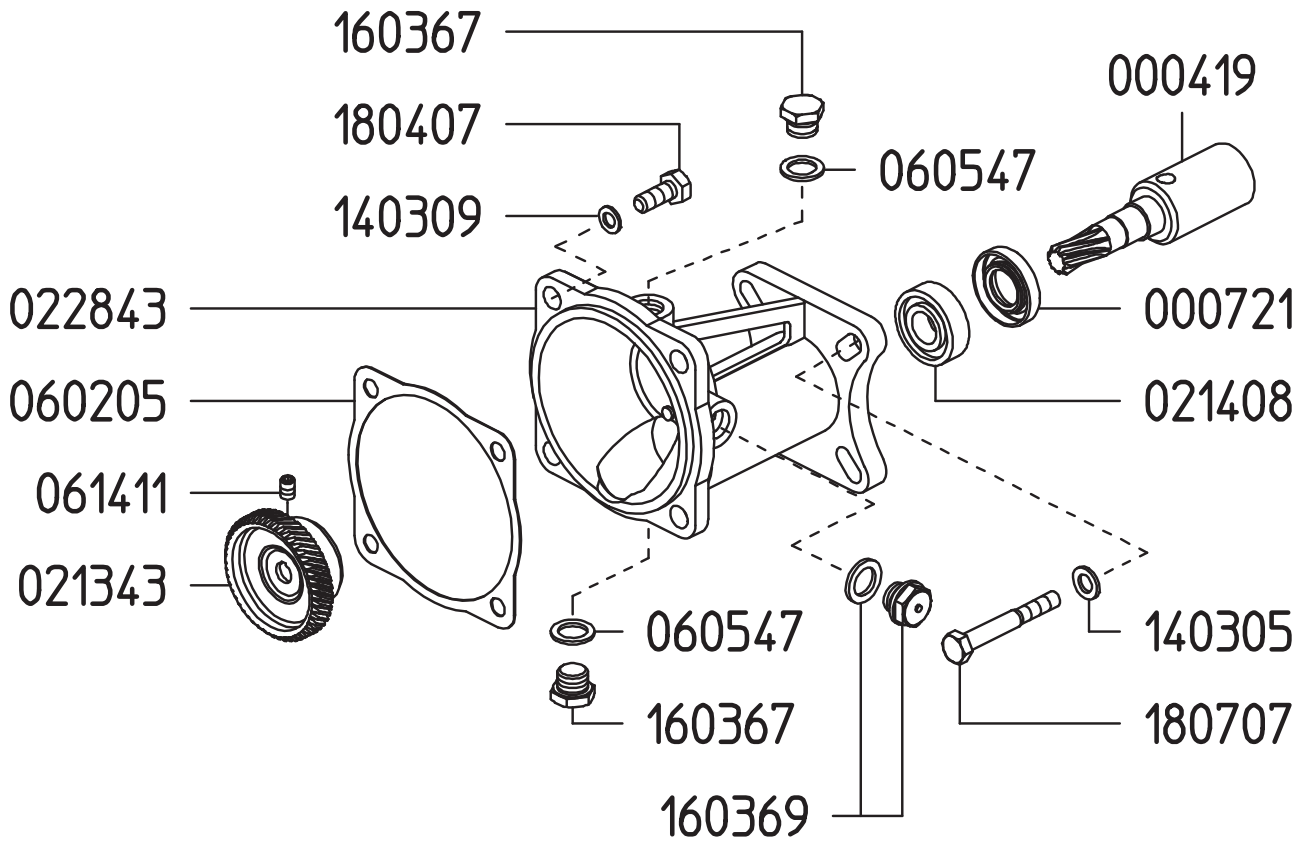

Revised 6-4-2024

Part #	Description	Qty	Part #	Description	Qty
0004.19	GEAR SHAFT "S124-3/4"/S151-3/4"	1	0614.11	SET SCREW M6X6 UNI5927	1
0007.21	OIL SEAL D17	1	1403.05	WASHER D8.4	4
0213.43	RED.GEAR WHEEL Z=40 "S151-GR"	1	1403.09	WASHER D10.5	4
0214.08	BALL BEARING D15	1	1603.67	PLUG G1/4	2
0228.43	COUPLER "S151"	1	1603.69	OIL PLUG G1/4 + GASKET	1
0602.05	GASKET	1	1804.07	HEX BOLT M10X25	4
0605.47	GASKET D13	2	1807.07	HEX BOLT 5/16X1" UNF	4

## Adjustable Pressure Regulator

Maximum Flow	27.0 GPM / 102 lpm
Maximum Pressure	350 PSI / 24 bar
Inlet Port - Hose Barb	-
Outlet Ports - Hose Barb, Valve	(2) 1/2" HB
Bypass - Hose Barb	3/4" HB

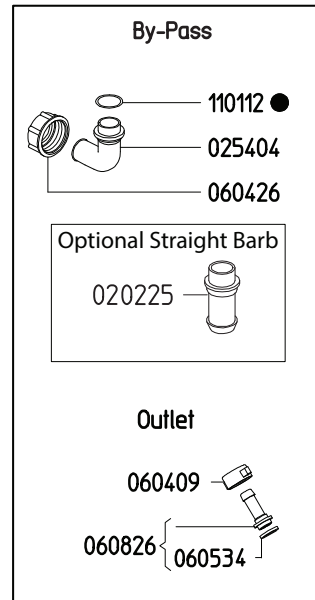
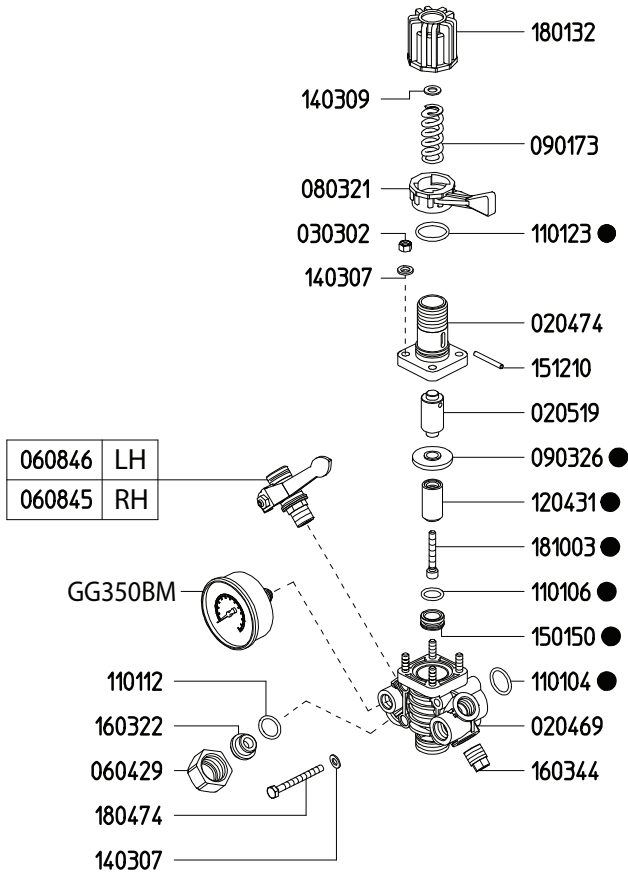

6062A9	
KIT 608	
CODE	QTY
090326	1
110104	1
110106	1
110112	1
110123	1
120431	1
150150	1
181003	1

Revised 6-4-2024

Part #	Description	Qty
0202.25	BYPASS HOSE BARB - STRAIGHT (OPTIONAL)	1
0204.69	BODY	1
0204.70	BODY	1
0205.19	CYLINDER	1
0254.04	BYPASS HOSE BARB - ELBOW	1
0303.02	NUT	4
0604.09	BARB NUT	2
0604.26	BYPASS BARB NUT	1
0604.29	NUT	1
0605.34	GASKET	2
0608.26	1/2" HOSE BARB W/GASKET	2
0608.45	BALL VALVE - RIGHT	1
0608.46	BALL VALVE - LEFT	1
0803.21	LEVER	1
0901.73	SPRING (LP 300 PSI)	1
0903.26	DIAPHRAGM ●	1
1101.04	O-RING ●	1

Part #	Description	Qty
1101.06	O-RING ●	1
1101.12	O-RING ●	2
1101.23	O-RING ●	1
1204.31	POPPET ●	1
1403.07	WASHER	6
1501.50	SEAT ●	1
1512.10	PIN	1
1603.22	PLUG	1
1603.44	PLUG	1
1801.32	ADJUSTMENT KNOB	1
1804.74	BOLT	2
1810.03	STAINLESS STEEL BOLT ●	1
6062.A9	REPAIR KIT FOR 6010.9X CONTROL UNIT (KIT 608)	1
GG350BM	PRESSURE GAUGE - 350 PSI BACK MOUNT	1

● Parts Included in Repair Kit #6062.A9 (KIT 608)

The control unit features a manual dump valve, pressure control knob, glycerine filled pressure gauge, and two ball valve discharge ports.

1. Before operating or re-operating the pump move lever (0803.21) to the dump position (Right) so the pump will start at zero pressure. (Failure to do so will void the pump warranty.)
2. Turn pressure adjustment knob (1801.32) counter clockwise to relieve spring tension. This step only applies to the initial start up and is not necessary in daily operation of pump.
3. Start unit and let run until air is evacuated from the system.
4. Move lever (0803.21) to the pressure position (Left) open spray gun or spray boom and turn the pressure adjustment knob (1801.32) clockwise until desired operating pressure is achieved.

# KAPPA 25 DIMENSIONS

All Dimensions are WITHOUT Control Unit or Regulator

Dimensional Drawings are Shown in Millimeters. To Convert to Inches, Multiply Dimension x 0.03937

## Specifications

## KAPPA 25

Inlet Port - Hose Barb	1" HB
Outlet Ports - Hose Barb	(2) 1/2" HB
Bypass - Hose Barb	3/4" HB
Dimensions	8.5"L x 9.0"W x 9.5"H
Diaphragm Material	GREENTECH (Std) Buna-N (Opt)

**Lubrication:** Requires 12 oz. of Udor Lube 40W Premium Pump Oil.  
Alternate Oil: 30W non-detergent or 15W-40 non-detergent oil.

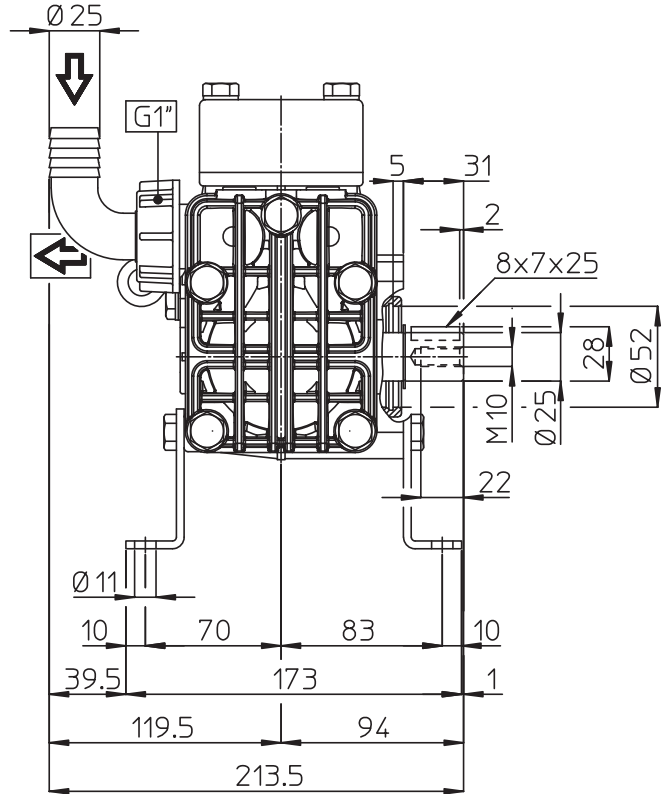
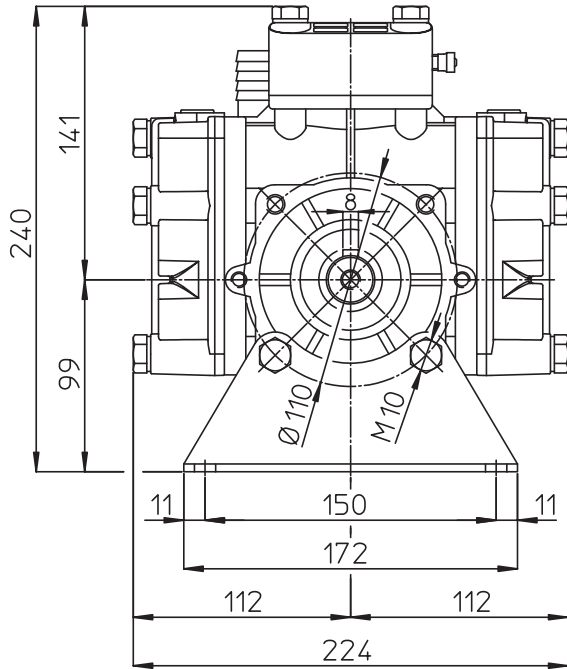

## TORQUE SPECS

Ref.	Description	Ft./lb.	Nm
1	Diaphragm Bolts (Use Loctite 243)	18	25
2	Head Bolts	30	40
3	Pulsation Dampener Bolts	30	40
4	Inlet Flange Bolts	-	-
5	Bearing Flange Bolts	-	-
6	Oil Cup Bolts	-	-
7	Valve Cover Bolts	-	-

