

Maximum Flow	35.0 GPM / 133 lpm
Maximum Pressure	700 PSI / 30 bar
Maximum RPM	550 RPM
Inlet Port - Hose Barb	1-1/2" HB
Outlet Ports - Hose Barb, Valve	3/4" HB
Bypass - Hose Barb	1" HB
Dimensions	15" L x 20.5" W x 16.0" H
Weight	105 lbs

Lubrication: Requires 84 oz. of Udor Lube 40W Premium Pump Oil.
Alternate Oil: 30W non-detergent or 15W-40 non-detergent oil.

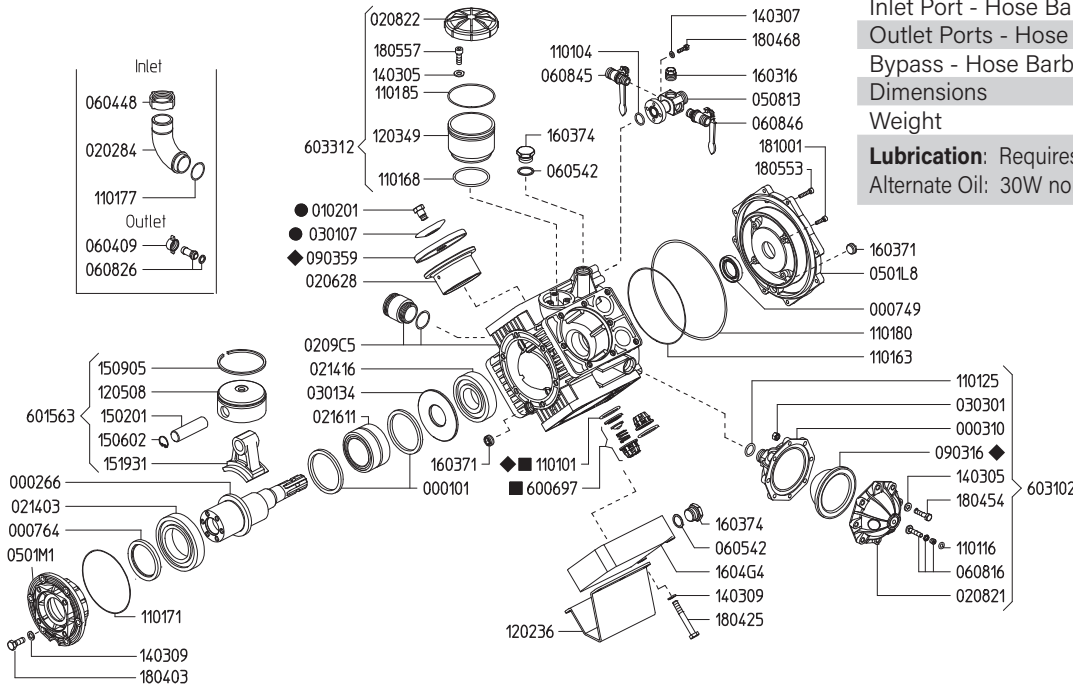

KIT 528		KIT 643		KIT 523	
606229		6062E1		606224	
◆		■		●	
CODE	QTY	CODE	QTY	CODE	QTY
090316	1	110101	8	010201	4
090359	4	600697	8	030107	4
110101	8				

Revised 6-24-2024

Part #	Description	Qty	Part #	Description	Qty
0001.01	RETAINER RING "BETA/OMEGA"	2	1101.71	O-RING - BEARING FLANGE	1
0002.66	SHAFT "KAPPA 121" TS VA	1	1101.77	O-RING D33.00 (RIF.3131)	1
0003.10	PRESSURE ACCUMULATOR BASE	1	1101.80	O-RING D208.92 (RIF.6820)	1
0007.49	OIL SEAL D35	1	1101.85	O-RING D83	1
0007.64	OIL SEAL D75	1	1202.36	BASE PLATE "KAPPA 121/151"	2
0102.01	DIAPHRAGM BOLT "ZETA/KAPPA 121" ●	4	1203.49	OIL RESERVOIR "BETA"	1
0202.84	HOSE BARB D40	1	1205.08	ALUMINIUM PISTON D75 "BETA/OMEGA/ZETA"	4
0206.28	SLEEVE D75 "KAPPA 121"	4	1403.05	WASHER D8.4	11
0208.21	ACCUMULATOR COVER "BETA"	1	1403.07	WASHER D6.4	4
0208.22	OIL RESERVOIR COVER "BETA"	1	1403.09	WASHER D10.5	22
0209.C5	CRANKASE "KAPPA 121/151"	1	1502.01	PIN D18X64	4
0214.03	BALL BEARING D75	1	1506.02	SNAP RING D18	4
0214.16	BALL BEARING D45	1	1509.05	PISTON RING D75	4
0216.11	BALL BEARING D45	1	1519.31	CONNECTING ROD "KAPPA 121/151"	4
0301.07	DIAPHRAGM DISC "ZETA/KAPPA 121/151" ●	4	1603.16	PLUG G1/2	1
0301.34	BEARING DISC "KAPPA 121/151"	1	1603.71	PLUG G1/2	2
0303.01	HEXAGONAL NUT M8X8 UNI5587-8G	8	1603.74	PLUG G3/4	5
0501.L8	CRANKASE FLANGE "KAPPA 121/151"	1	1604.G4	HEAD "KAPPA 121/151"	4
0501.M1	BUSHING FLANGE "KAPPA 121/151" VA	1	1804.03	HEX SCREW M10X30 UNI5739	6
0508.13	FLANGE G3/4 M - G3/8 F	1	1804.25	HEX SCREW M10X75 UNI5737	16
0604.09	BRASS NUT G1/2	1	1804.54	HEX SCREW M8X35 UNI5737	8
0604.48	BRASS NUT M48X2	2	1804.68	HEX SCREW M6X22 UNI5739	4
0605.42	GASKET D27	5	1805.53	ALLEN SCREW M6X22 UNI5931 DACROMET	8
0608.16	AIR VALVE ASSY	1	1805.57	ALLEN SCREW M8X22 UNI5931	3
0608.26	HOSE BARB D13+GASKET	2	1810.01	ALLEN SCREW M6X30 UNI5931 SS	4
0608.45	BALL VALVE RIGHT	1	6006.97	VALVE ASSY "OMEGA/BETA" W/O O-RING ◆	8
0608.46	BALL VALVE LEFT	1	6015.63	ROD ASSY "KAPPA 121/151" D75	4
0903.16	ACCUMULATOR DIAPH. "BETA/OMEGA" ■	1	6031.02	PRESSURE ACCUMULATOR ASSY "BETA"	1
0903.59	PISTON DIAPHRAGM "ZETA" D115.4 DESM ■	4	6033.12	OIL RESERVOIR ASSY "BETA"	1
1101.01	O-RING D39.70 (RIF. 144) ■◆	8	6062.24	DIAPH DISC "ZETA 170" (KIT 523)	
1101.04	O-RING D20.63 (RIF.128)	1	6062.29	DIAPHRAGM KIT "KAPPA 121" DESM (KIT 528)	
1101.16	O-RING D6 (RIF.1263)	1	6062.E1	IN/OUTLET VALVE KIT "BETA 150" (KIT643)	
1101.25	O-RING D20.22 (RIF.4081)	1			
1101.63	O-RING D152	1			
1101.68	O-RING D60.32 (RIF.164)	1			

- Parts in 6062.24 (Kit 523).
- Parts in 6062.29 (Kit 528).
- ◆ Parts in 6062.E1 (Kit 643).

**GAS ENGINE GEAR REDUCTION FOR
DELTA-100/KAPPA-121 DIAPHRAGM PUMPS
on 16.0-22.0 HP GAS ENGINES with 1" SHAFTS
REQUIRES 28 OZ. 90W GEAR LUBE**

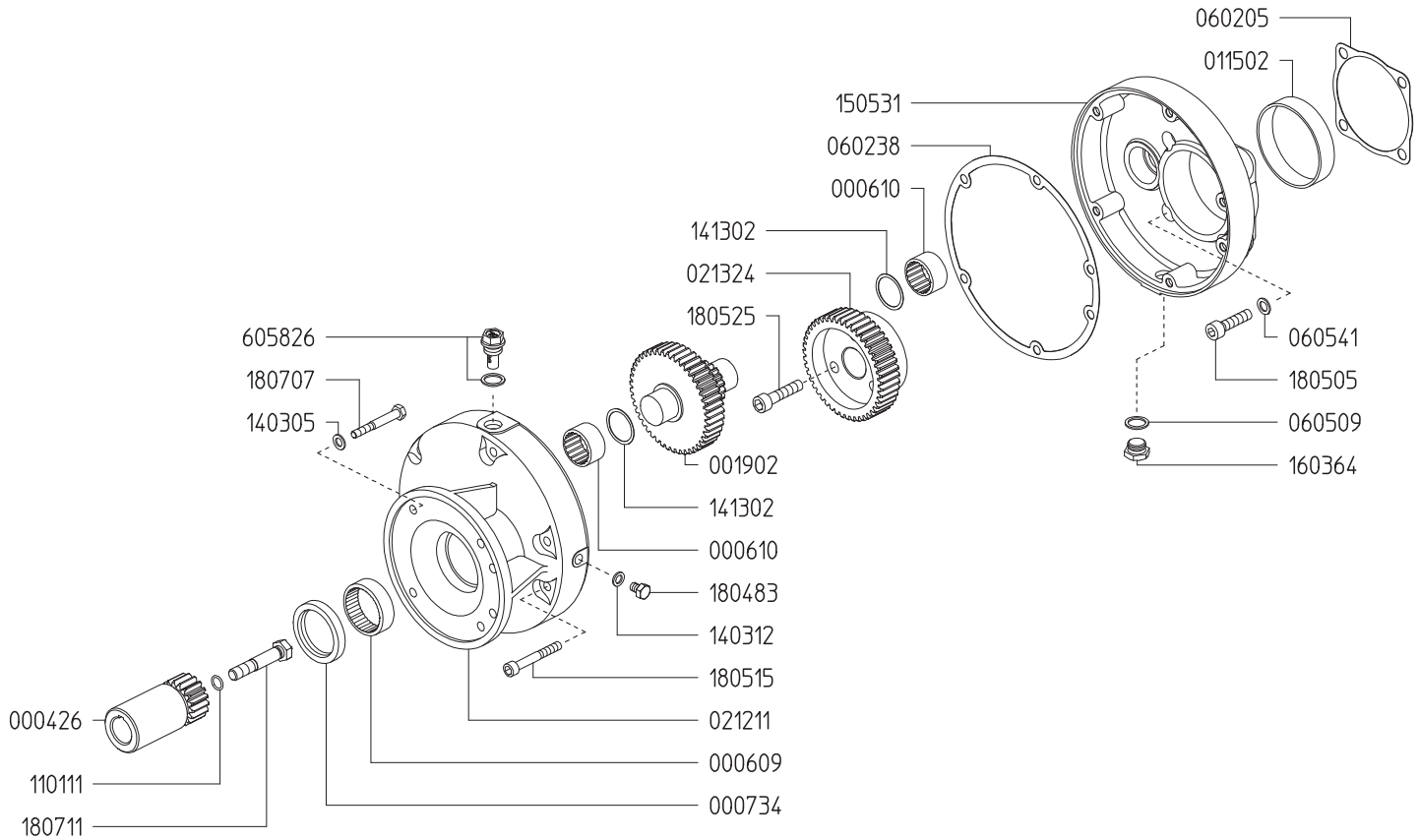

Part #	Description	Qty	Part #	Description	Qty
0004.26	GEAR SHAFT "M162-1"VA"	1	1403.05	WASHER D8.4	4
0006.09	BUSHING D45	1	1403.12	GASKET D8.5	1
0006.10	BUSHING D30	2	1413.02	WASHER D30	2
0007.34	OIL SEAT D45	1	1505.31	GEAR BODY "M162"	1
0019.02	GEAR SHAFT "M162"	1	1603.64	PLUG G3/8	1
0115.02	BUSHING D80 GLY	1	1804.83	HEX SCREW M8X12 UNI5739	1
0212.11	REDUCER COVER "M162"	1	1805.05	ALLEN SCREW M10X30 UNI5931	4
0213.24	RED.GEAR WHEEL Z=45 "M162-VA"	1	1805.15	ALLEN SCREW M8X60 UNI5931	6
0602.05	GASKET	1	1805.25	ALLEN SCREW M10X45 UNI5931	3
0602.38	GASKET "M162"	1	1807.07	HEX SCREW 5/16X1" UNF	4
0605.09	GASKET D17	1	1807.11	HEX SCREW 7/16"X2" UNF	1
0605.41	GASKET D10	4	6058.26	OIL PLUG G3/8	1
1101.11	O-RING D11.11 (RIF.114)	1			