

- Anodized Aluminum Crank Case
- Nickel-Plated Manifold
- Stainless Steel Check Valves
- Heavy Duty Bronze Connecting Rods
- Heavy Duty Roller Bearings
- 2-1/2" BSP-F Inlet. 1-1/4" BSP-F Outlet
- Max Fluid Temp, 160°F

HXR Series Plunger Pumps

HXR Series industrial duty plunger pumps are rated at 32.9 to 104.4 GPM and pressures up to 4350 PSI.

Gear reduction models are available in 1500, 1800 or 2200 RPM models with a 50mm solid, keyed shaft.

Applications include sewer jetting, hydro-excavation, fire fighting, mining and street cleaning.

	Model	Flow		Pressure		Plunger Dia.	Crankshaft		Power	Seal Kit	Valve Kit	Wt.
		GPM	l/min	PSI	bar		Stroke	Code				
1800 RPM	HXR1-D 135/300 R	32.9	124.5	4350	300	32mm	70.0mm	35	95.8 EBHP	6700.09	6072.03	367.5 lbs
	HXR1-D 160/240 R	42.9	162.5	3480	240	36mm	70.0mm	35	100.0 EBHP	6700.10	6072.03	367.5 lbs
	HXR1-D 210/200 R	54.4	206	2900	200	40mm	70.0mm	35	105.7 EBHP	6700.07	6072.13	367.5 lbs
2.238:1 Gear Ratio	HXR1-D 270/160 R	68.7	260	2320	160	45mm	70.0mm	35	106.8 EBHP	6700.08	6072.13	367.5 lbs
	HXR1-D 330/130 R	86.1	326.0	1885	130	50mm	70.0mm	35	108.7 EBHP	6072.14	6072.13	367.5 lbs
	HXR1-D 400/100 R	104.4	395.1	1450	100	55mm	70.0mm	35	101.3 EBHP	6072.16	6072.13	367.5 lbs



MAX FLOW
MAX PRESSURE
RATED PUMP SPEED
POWER REQUIREMENT
LUBRICATION

54.4 GPM / 206 L/MIN
2900 PSI / 200 BAR
1800 RPM
105.7 HP ELECTRIC
237 OZ 85W-90 OIL

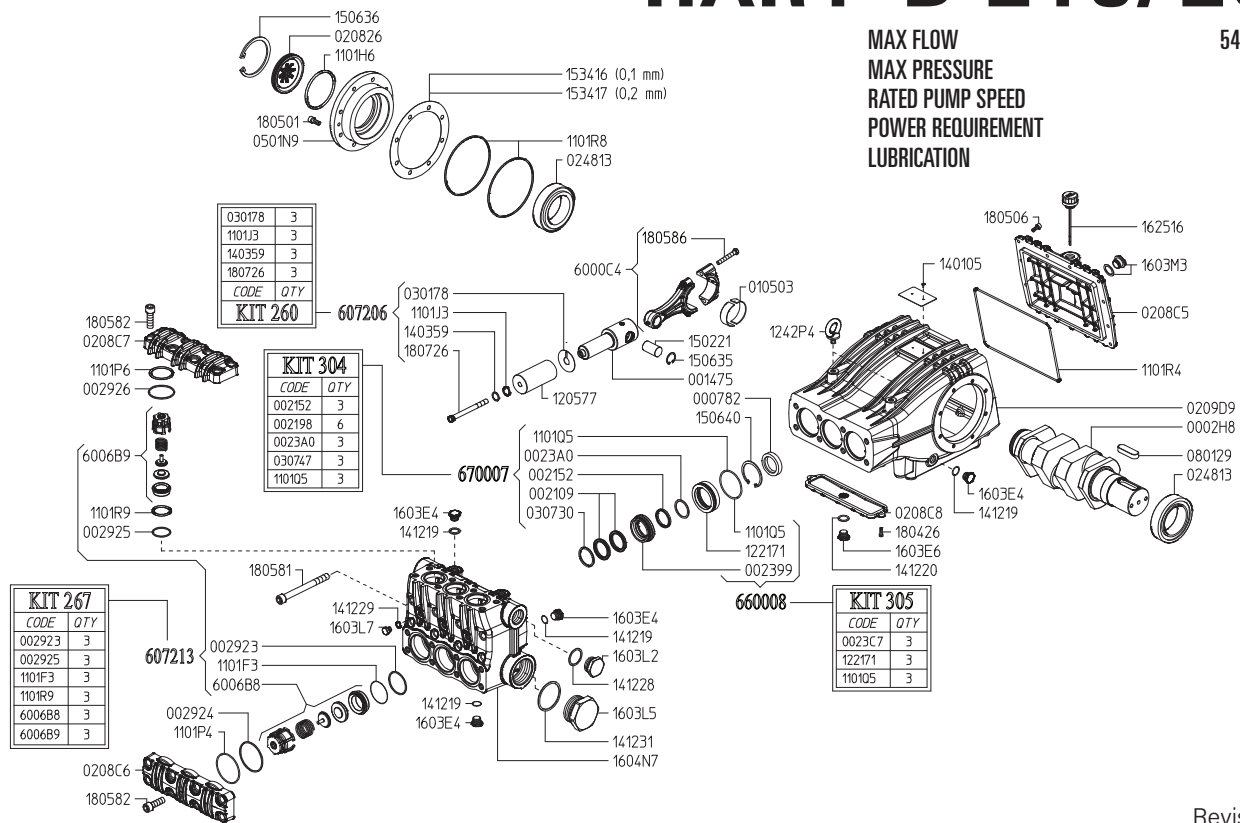

Revised 2-5-2024

Part #	Description	Qty	Part #	Description	Qty
0002.H8	PUMP CRANCKSHAFT	1	1412.19	BONDED SEAL G1/2"	10
0007.82	D40 VITON SHAFT SEAL	3	1412.20	BONDED SEAL G3/4"	1
0014.75	PLUNGER GUIDE	3	1412.28	BONDED SEAL G1"	1
0021.52	LOW PRESSURE SEAL RING D40 ^B	3	1412.29	BONDED SEAL G1/4"	3
0021.98	HIGH PRESSURE SEAL RING D40 ^B	6	1412.31	BONDED SEAL G2"	1
0023.A0	SCRAPER RING D40 ^B	3	1502.21	PIN	3
0023.C7	UPPER RING D40 ^C	3	1506.35	SNAP RING D28 UNI7437	6
0029.23	ANTI EXTRUSION RING ^A	3	1506.36	SNAP RING D55 UNI7437 INOX	1
0029.25	ANTI EXTRUSION RING ^A	3	1506.40	SNAP RING D72 UNI7437	3
0029.24	ANTI EXTRUSION RING	6	1534.16	SHIM 0,1mm	1
0105.03	BUSHING	3	1534.17	SHIM 0,2mm	1
2008.26	OIL LEVEL SIGHT GLASS	1	1603.E4	INOX PLUG G1/2"	10
0208.C5	REAR COVER	1	1603.E6	INOX PLUG G3/4"	1
0208.C6	VALVE COVER	1	1603.L2	INOX PLUG G1"	1
0208.C7	VALVE COVER	1	1603.L5	INOX PLUG G2"	1
0208.C8	INFERIOR COVER	1	1603.L7	INOX PLUG G1/4"	3
0209.D9	CRANCKCASE	1	1603.M3	OIL LEVEL SIGHT GLASS G3/4"	1
0248.13	BEARING	2	1604.N7	PUMP HEAD "HX-HP"	1
0301.78	SEPARATING DISC ^D	3	1625.16	OIL VENT PLUG G3/4"	1
0307.47	RING D40 ^B	3	1804.26	HEX SCREW M6X20 UNI 5739 ZINC PLATED	2
0501.N9	CLOSED BEARING FLANGE	1	1805.01	SOCKET HEAD SCREW M10X25 UNI5931 ZINC PLATED	8
0801.29	KEY A22X14X70 UNI6604-A	1	1805.06	SOCKET HEAD SCREW M8X20 UNI5931 ZINC PLATED	12
1101.F3	O-RING ^A	3	1805.81	SOCKET HEAD SCREW M18X180 UNI5931 12.9 GEOMET	8
1101.H6	OR D47,29X2,62 RIF 3187	1	1805.82	SOCKET HEAD SCREW M18X60 UNI5931 12.9 GEOMET	16
1101.J3	OR D10,78X2,62 RIF 3043 90SHORE ^D	3	1805.86	HEX SCREW M10X65	6
1101.P4	OR D57,15X3,53 RIF 161	6	1807.26	HEX SCREW M12X130 DIN6921 INOX ^D	3
1101.Q5	OR D75,79X3,53 RIF 4300 ^{B,C}	3	6000.C4	PISTON ROD SUBASSEMBLY	3
1101.R4	OR D275,00x4,00 RIF 2750-40	1	6006.B8	VALVE SUBASSEBLY ^A	3
1101.R8	OR D158,3x3.53 RIF 4625	2	6006.B9	VALVE SUBASSEBLY ^A	3
1101.R9	OR D44,04X3,53 RIF 4175 90SHORE ^A	3	^D 6072.06	KIT 260	
1205.77	PISTON D40	3	^A 6072.13	KIT 267	
1221.71	PRESSURE RING D40 ^C	3	^C 6600.08	KIT 305	
1242.P4	M12 UNI-ISO3266 ZINC PLATED EYEBOLT	2	^B 6700.07	KIT 304	
1403.59	WASHER ^D	3			

RH118 GEAR REDUCER

2.238:1 PTO GEAR REDUCTION
for HXR1-D ___/___ R PUMPS
REQUIRES 101 OZ. 85W-90 GEAR LUBE

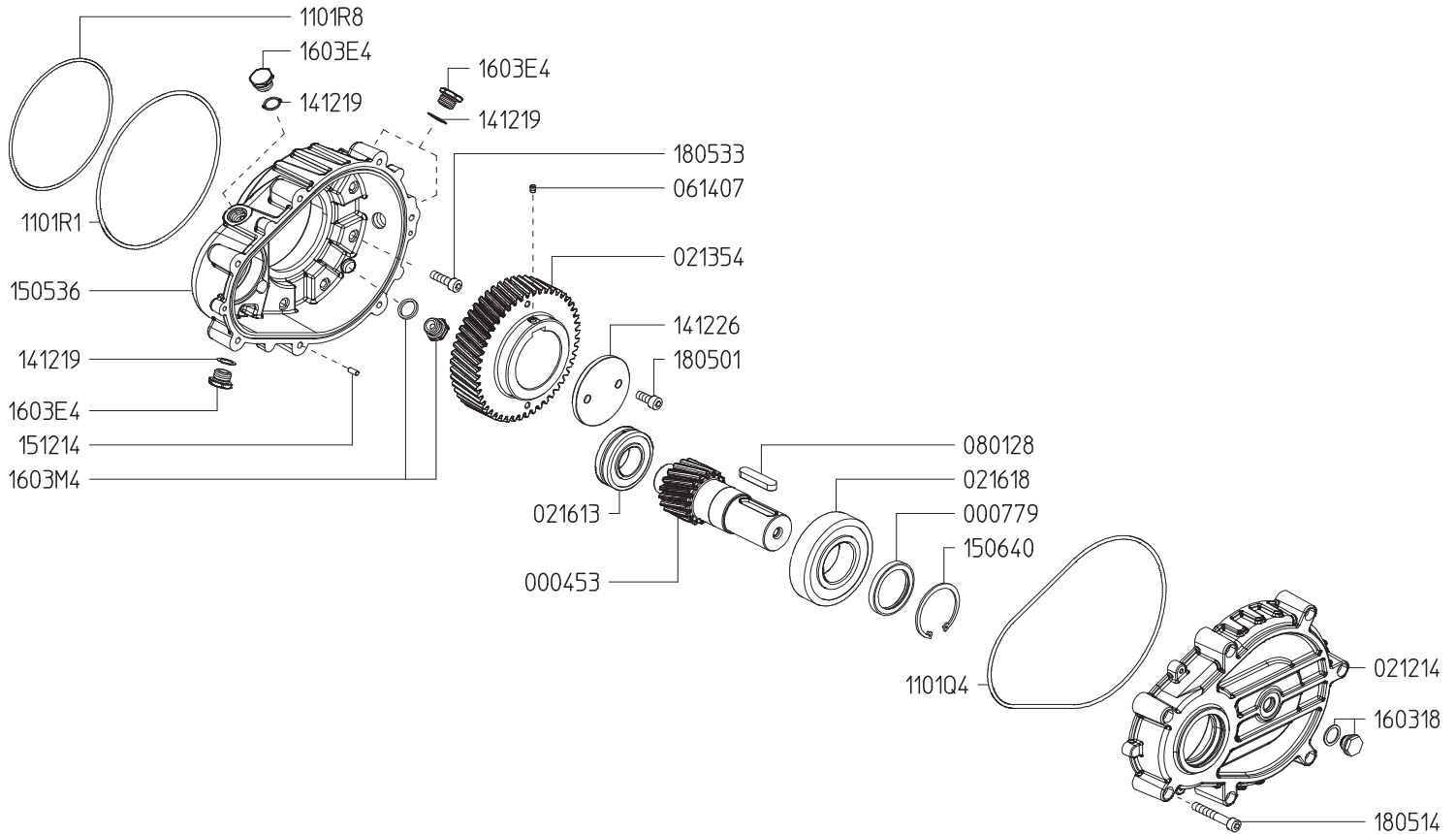

Part #	Description	Qty	Part #	Description	Qty
0004.53	PINION "RH 118"	1	1412.26	WASHER	1
0007.79	SHAFT SEAL D55 VITON	1	1412.19	BONDED SEAL G1/2"	4
0212.14	GEARBOX COVER	1	1505.36	GEARBOX CASE	1
0213.54	GEAR "RH 118"	1	1506.40	SNAP RING D72 UNI7437 ZINC PLATED	1
0216.13	BEARING	1	1512.14	CYLINDRICAL PIN D6,0X14 UNI-EN 28734	2
0216.18	BEARING	1	1603.18	OIL LEVEL SIGHT GLASS PLUG G1/2"	1
0614.07	SOCKET SET SCREW M8X10 UNI5929	1	1603.E4	INOX PLUG G1/2"	4
0801.28	KEY A14X9X60 UNI6604-A	1	1603.M4	MAGNETIC PLUG G1/2"	1
1101.R1	OR D209,15X3,53 RIF 4825	1	1805.01	SOCKET HEAD SCREW M10X25 UNI5931 ZINC PLATED	2
1101.Q4	OR D266,30X3,53 RIF 41050	1	1805.33	SOCKET HEAD SCREW M10X35 UNI5931 ZINC PLATED	8
1101.R8	OR D158,3x3,53 RIF 4625	1	1805.14	SOCKET HEAD SCREW M10X60 UNI5931 ZINC PLATED	7

HXR SERIES PUMPS - 50mm SOLID SHAFT

WEIGHT
LUBRICATION - PUMP
- GEARBOX

411.5 LBS
237 OZ 85W-90 OIL
101 OZ 85W-90 OIL

*Dimensional Drawings are
Shown in Millimeters.
To Convert to Inches,
Multiply Dimension x 0.03937*

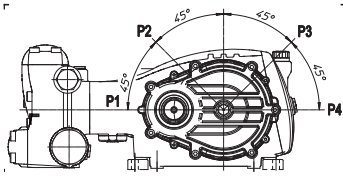

Depending on specific needs, the Gearbox can be mounted in four different positions P1,P2,P3,P4 as shown in the picture at left.

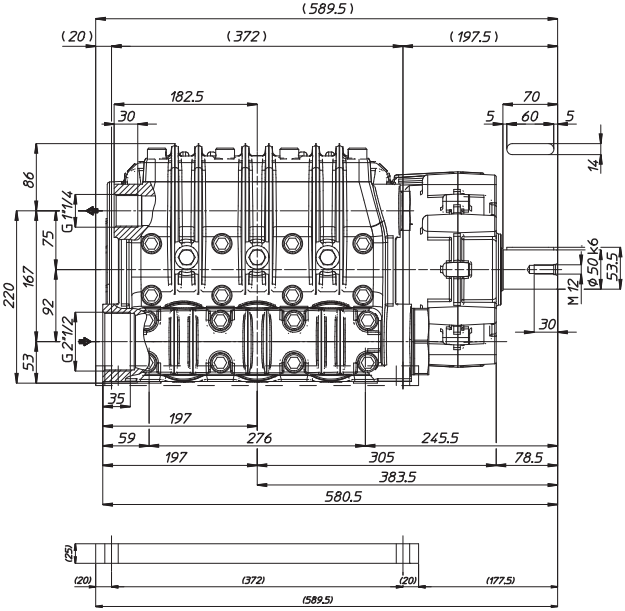
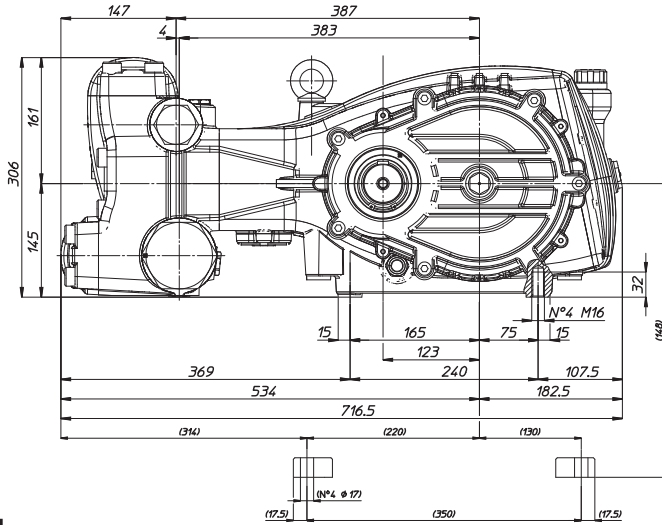

TORQUE SPECS

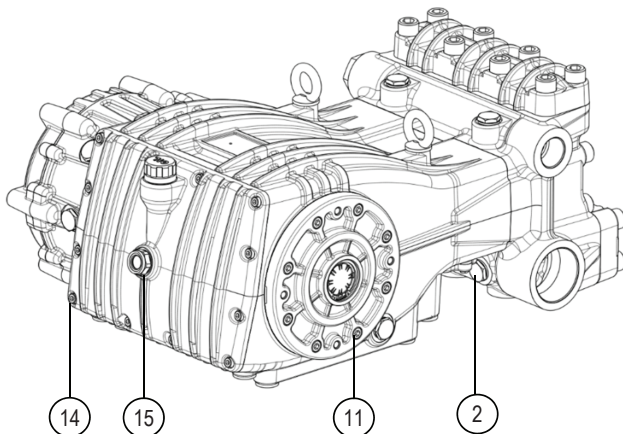
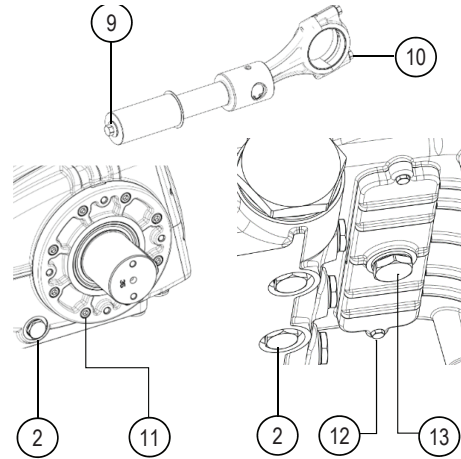
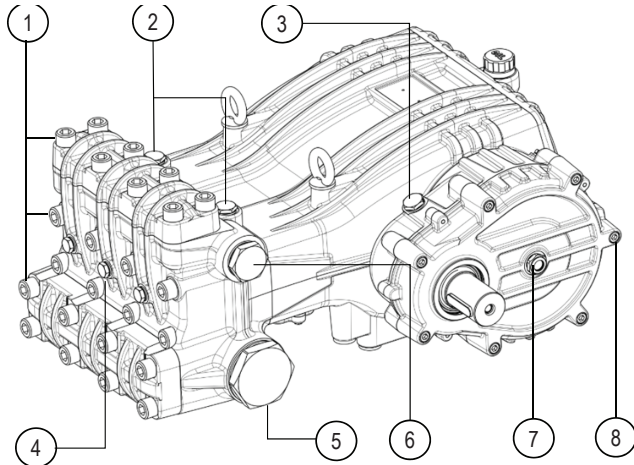

Position	Description	Torque	
1	Head M18 screw Valve cover M18 screw	450 Nm	332 ft/lb
2	Plug G1/2"	100 Nm	74 lb/ft
	Plug G1/2" 74 lb/ft	100 Nm	74 lb/ft
3	Magnetic plug G1/2"	25 Nm	18.4 lb/ft
	Plug G1/4"	50 Nm	37 lb/ft
5	Plug G2"	250 Nm	184.4 lb/ft
	Plug G2"- 1/2		
6	Plug G1"-1/4 74 lb/ft	250 Nm	184.4 lb/ft
	Plug G1"	200 Nm	147.5 lb/ft
7	Oil level sight glass G1/2"	25 Nm	18.4 lb/ft
8	Screw M10	50 Nm	37 lb/ft
9	Screw M12	50 Nm	37 lb/ft
10	Screw M10	50 Nm	37 lb/ft
11	Screw M10	50 Nm	37 lb/ft
12	Screw M6	11 Nm	8.1 lb/ft
13	Plug G3/4"	100 Nm	74 lb/ft
14	Screw M8	25 Nm	18.4 lb/ft
15	Oil level sight glass G3/4"	25 Nm	18.4 lb/ft