

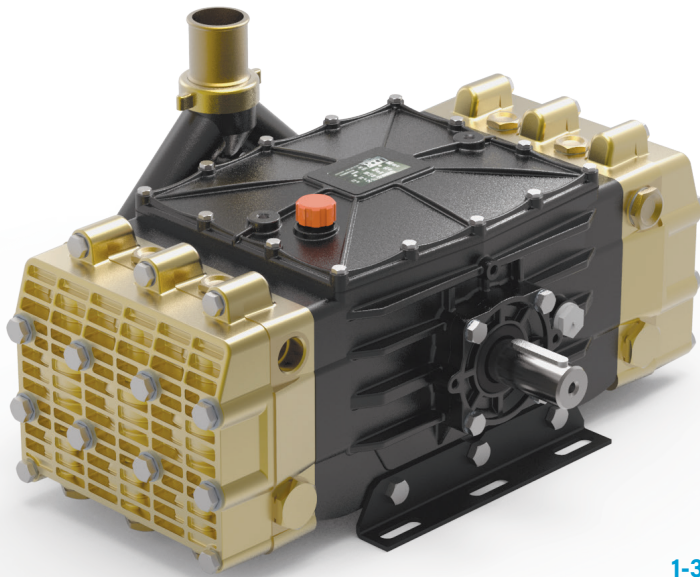

GAMMA-IL 200 SERIES

1-3/8" 6 Spline PTO Thru Shaft

Multiple Drive Options Available
600 RPM



- Heavy Duty Brass Manifold
- Solid Ceramic Plungers
- Stainless Steel Plunger Guides and Check Valves
- Bronze Connecting Rods
- 2" Hose Barb Inlet
- (4) 3/4" BSP-F Outlet
- 64 oz. Capacity Vented Oil Bath Crank Case
- Max Fluid Temp, 160°F

TS 1C
1-3/8" PTO x
35mm Keyed



TS 2C
1-3/8" PTO x
1-3/8" PTO



GAMMA-IL 200 Series Plunger Pumps

GAMMA-IL 200 Series industrial duty plunger pumps are rated at 54.5 GPM and pressures up to 1160 PSI.

Pumps are available with a 1-3/8" male PTO through shaft with the option of a 2nd 1-3/8" male PTO shaft or a 35mm solid, keyed shaft.

Applications include fire fighting,, construction, and vehicle wash systems.

	Model	Flow		Pressure		Plunger Dia.	Crankshaft		Power	Seal Kit	Valve Kit	Wt.
		GPM	l/min	PSI	bar		Stroke	Code				
600 RPM	GAMMA-IL 200 TS 1C	54.4	202.0	1160	80	50mm	30.4mm	L	42.2 EBHP	6062.71	6062.70	152 lbs
	GAMMA-IL 200 TS 2C	54.4	202.0	1160	80	50mm	30.4mm	L	42.2 EBHP	6062.71	6062.70	152 lbs



6180 140th Avenue NW
Ramsey, MN 55303

Ph: 651-785-0666
Fax: 800-732-2670

www.udorusa.com
www.boominator.com
info@udorusa.com



Scan this QR Code
for More Information

GIL200TS
2024A

MAX FLOW
MAX PRESSURE
RATED PUMP SPEED
POWER REQUIREMENT
LUBRICATION

54.4 GPM / 202.0 L/MIN
1160 PSI / 80 BAR
600 RPM
42.2 HP ELECTRIC
64 OZ UDOOR LUBE

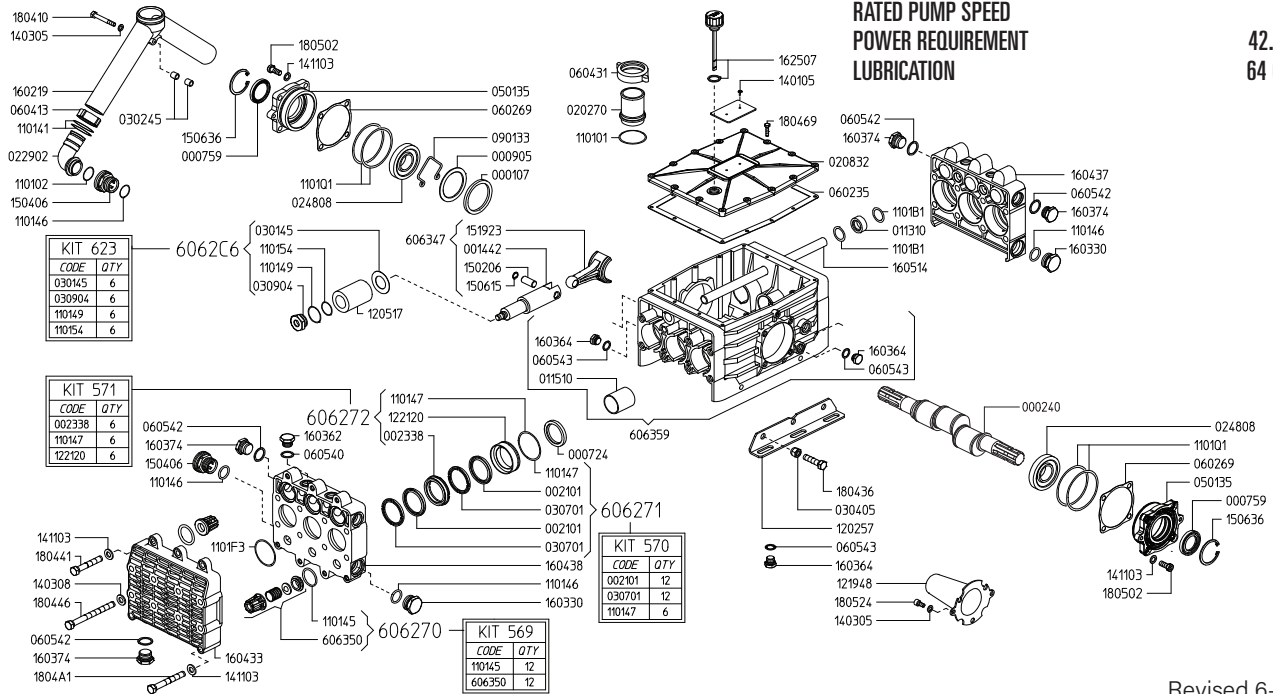

Revised 6-2-2023

Part #	Description	Qty	Part #	Description	Qty
0001.07	RETAINER RING	6	1219.15	PTO DRIVE SHAFT GUARD "UNIVERSAL"	6
0002.40	SHAFT TS2C	1	1221.20	PRESSURE RING D50 ^C	6
0007.24	OIL SEAL D40	6	1401.05	RIVET UNI7346-3.5X8	2
0007.59	OIL SEAL D35	2	1403.05	WASHER D8.4	3
0009.05	RING	6	1403.08	WASHER D13	16
0014.42	PLUNGER GUIDE	6	1411.03	SERATED WASHER D10	15
0021.01	PISTON SEAL RING D50 ^B	12	1502.06	PIN D15X32.3	6
0023.38	UPPER RING D50 ^C	6	1504.06	BRASS INLET CONNECTOR	2
0113.10	BALANCING TUBE BUSHING	2	1506.15	SNAP RING D15	6
0115.10	BUSHING D40	6	1506.36	SNAP RING D55	2
0202.70	HOSE BARB D50	1	1519.23	CONNECTING ROD	6
0208.32	UPPER COVER	1	1602.19	SUCTION MANIFOLD G2"	1
0209.24	CRANKCASE	1	1603.06	OIL PLUG G1/2 + GASKET	2
0229.02	BRASS ELBOW	2	1603.30	PLUG G1"	2
0248.08	ROLLER BEARING D35	2	1603.62	PLUG G1/2	4
0301.45	DISC ^D	6	1603.64	PLUG G3/8	3
0302.45	SPACER	2	1603.74	PLUG G3/4	9
0304.05	SELF LOCKING NUT M12	6	1604.33	FRONT HEAD	2
0307.01	SPACER RING D50 ^B	12	1604.37	MIDDLE HEAD - LEFT	1
0309.04	NUT D50 ^D	6	1604.38	MIDDLE HEAD - RIGHT	1
0501.35	BEARING FLANGE	2	1605.14	BALANCING TUBE	1
0602.35	UPPER COVER GASKET	1	1625.07	OIL PLUG G1/2	1
0602.69	FLANGE GASKET	2	1804.10	HEX BOLT M8X60	1
0604.13	BRASS NUT M46X2	2	1804.36	HEX BOLT M12X50	6
0604.31	BRASS NUT G2"	1	1804.41	HEX BOLT M10X35	5
0605.40	GASKET D21.5	4	1804.46	HEX BOLT M12X130	16
0605.42	GASKET D27	9	1804.69	HEX BOLT M6X25	12
0605.43	GASKET D17	3	1804.A1	HEX BOLT M10X70	2
0901.33	SPRING CLIP	6	1805.02	ALLEN BOLT M10X25	8
1101.01	O-RING - INLET HOSE BARB	1	1805.24	ALLEN BOLT M8X16	2
1101.02	O-RING - INLET ELBOW	2	6063.47	COMPLETE ROD ASSEMBLY	6
1101.41	O-RING - INLET MANIFOLD	4	6063.50	VALVE ASSEMBLY W/O O-RING ^A	12
1101.45	O-RING - VALVE ^A	12	6063.U7	CRANKCASE ASSEMBLY	1
1101.46	O-RING - INLET PORT	4	6062.70	IN/OUTLET VALVE KIT (KIT 569)	1
1101.47	O-RING - PRESSURE RING ^{B,C}	6	6062.71	WATER SEAL KIT (KIT 570)	1
1101.49	O-RING - PLUNGER BOLT, OUTER ^D	6	6062.72	BRASS RING KIT (KIT 571)	1
1101.54	O-RING - PLUNGER BOLT, INNER ^D	6	6062.C6	PLUNGER KIT (KIT 623)	1
1101.B1	O-RING - BALANCING TUBE	4			
1101.F3	O-RING - SPLIT MANIFOLD	6			
1101.Q1	O-RING - BEARING FLANGE	4			
1202.57	BASE PLATE	2			
1205.17	CERAMIC PLUNGER D50	6			

^A Parts in 6062.70 (Kit 569).

^B Parts in 6062.71 (Kit 570).

^C Parts in 6062.72 (Kit 571).

^D Parts in 6062.C6 (Kit 550).



GAMMA-IL 160/200 DIMENSIONS

WEIGHT 152 LBS
 LUBRICATION 64 OZ UDOR LUBE
 SHAFT OPTIONS
 TS1C ... 1-3/8" 6-Spline Male PTO x 35mm Solid Keyed Thru-Shaft
 TS2C 1-3/8" 6-Spline Male PTO Thru-Shaft

*Dimensional Drawings are
 Shown in Millimeters.
 To Convert to Inches,
 Multiply Dimension x 0.03937*

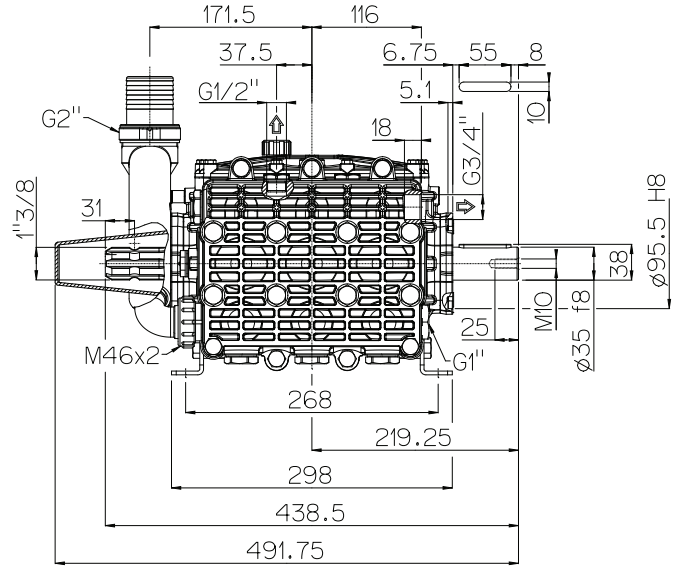
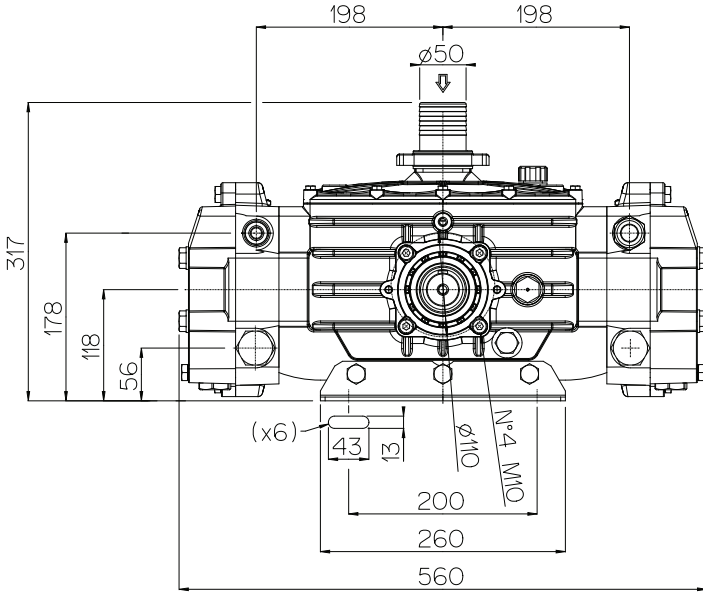

TORQUE SPECS

Ref.	Description	Ft./lb.	Nm	Loctite®
1	Head Bolts	66	90	-
2	Valve Caps	-	-	-
3	Inlet Cap	133	180	-
4	Outlet Cap	103	140	243
5	Bearing Flange Bolts	37	50	-
6	Rear Cover Bolts	8	11	-
7	Connecting Rod Bolts	-	-	-
8	Plunger Bolts	48	65	243
9	Valve Cover Bolts	-	-	-
10	Oil Drain Plug	8	11	-

