



GAMMA-IL 103 SERIES

1-3/8" 6 Spline PTO Thru Shaft

Multiple Drive Options Available
600 RPM



- Heavy Duty Brass Manifold
- Solid Ceramic Plungers
- Stainless Steel Plunger Guides and Check Valves
- Bronze Connecting Rods
- 1-1/4" Hose Barb Inlet
- (2) 3/4" BSP-F Outlet
- 128 oz. Capacity Vented Oil Bath Crank Case
- Max Fluid Temp, 160°F

TS 1C
1-3/8" PTO x
35mm Keyed



TS 2C
1-3/8" PTO x
1-3/8" PTO



GAMMA-IL 103 Series Plunger Pumps

GAMMA-IL 103 Series industrial duty plunger pumps are rated at 28.3 GPM and pressures up to 1450 PSI.

Pumps are available with a 1-3/8" male PTO through shaft with the option of a 2nd 1-3/8" male PTO shaft or a 35mm solid, keyed shaft.

Applications include fire fighting,, construction, and vehicle wash systems.

	Model	Flow		Pressure		Plunger Dia.	Crankshaft		Power	Seal Kit	Valve Kit	Wt.
		GPM	l/min	PSI	bar		Stroke	Code				
600 RPM	GAMMA-IL 103 TS 1C	28.3	107.0	1450	100	50mm	30.4mm	L	6062.50	6062.49	118 lbs	140 lbs
	GAMMA-IL 103 TS 2C	28.3	107.0	1450	100	50mm	30.4mm	L	6062.50	6062.49	118 lbs	115 lbs



6180 140th Avenue NW
Ramsey, MN 55303

Ph: 651-785-0666
Fax: 800-732-2670

www.udorusa.com
www.boominator.com
info@udorusa.com



Scan this QR Code
for More Information

GIL103TS
2024A

MAX FLOW 28.3 GPM / 107.0 L/MIN
MAX PRESSURE 1450 PSI / 100 BAR
RATED PUMP SPEED 600 RPM
POWER REQUIREMENT 27.4 HP ELECTRIC
LUBRICATION 128 OZ UDOR LUBE

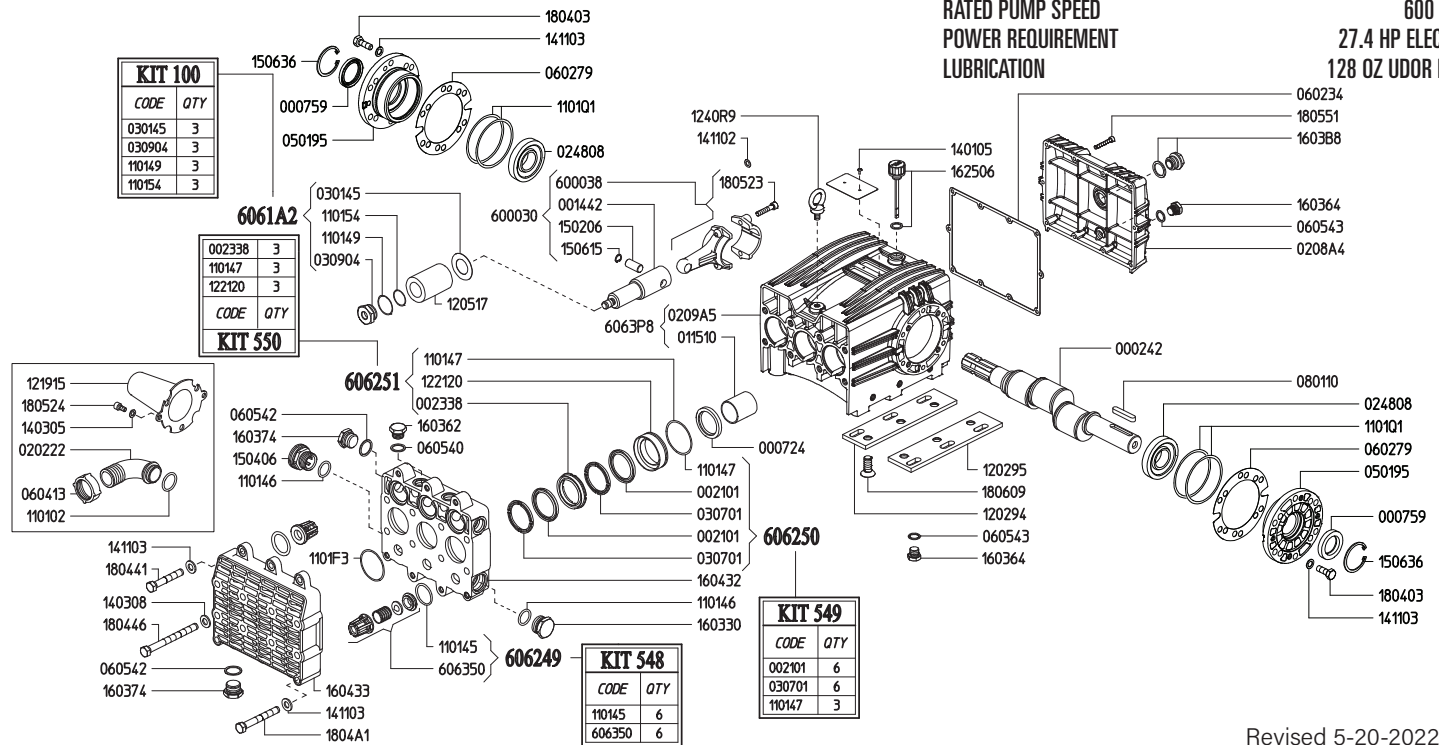

Revised 5-20-2022

Part #	Description	Qty	Part #	Description	Qty
0002.42	SHAFT TS1C	1	1401.05	RIVET 3.5X8	2
0007.24	OIL SEAL D40	3	1403.05	WASHER D8.4	2
0007.49	OIL SEAL D35	2	1403.08	WASHER D13	8
0014.42	PLUNGER GUIDE	3	1411.02	SERATED WASHER D8	6
0021.01	PISTON SEAL RING D50 ^C	6	1411.03	SERATED WASHER D10	15
0023.38	UPPER RING D50 ^D	3	1502.06	PIN D15X32.3	3
0115.10	BUSHING D40	3	1504.06	BRASS INLET CONNECTOR	1
0202.22	HOSE BARB D36	1	1506.15	SNAP RING D15	3
0208.A4	BACK COVER	1	1506.36	SNAP RING D55	2
0209.A5	CRANKCASE	1	1603.30	PLUG G1"	1
0248.08	ROLLER BEARING D35	2	1603.62	PLUG G1/2	2
0301.45	DISC ^A	3	1603.64	PLUG G3/8	2
0307.01	SPACER RING D50 ^B	6	1603.74	PLUG G3/4	3
0309.04	NUT D50 ^A	3	1603.B8	OIL PLUG G3/4 + GASKET	1
0501.95	BEARING FLANGE	2	1604.32	MIDDLE HEAD	1
0602.34	BACK COVER GASKET	1	1604.33	FRONT HEAD	1
0602.79	FLANGE GASKET	2	1625.06	OIL PLUG G1/2	1
0604.13	BRASS NUT M46X2	1	1804.03	HEX BOLT M10X30	8
0605.40	GASKET D21.5	2	1804.41	HEX BOLT M10X35	5
0605.42	GASKET D27	3	1804.46	HEX BOLT M12X130	8
0605.43	GASKET D17	2	1804.A1	HEX BOLT M10X70	2
0801.10	KEY A10X8X55	1	1805.23	ALLEN BOLT M8X40	6
1101.02	O-RING - INLET HOSE BARB	1	1805.24	ALLEN BOLT M8X16	2
1101.45	O-RING - VALVE ^B	6	1805.51	ALLEN BOLT M6X40	10
1101.46	O-RING - INLET PORT	2	1806.09	SCREW M14X35	6
1101.47	O-RING - PRESSURE RING ^{C,D}	3	6000.38	ROD ASSEMBLY	3
1101.49	O-RING - PLUNGER BOLT, OUTER ^A	3	6063.50	VALVE ASSEMBLY W/O O-RING ^B	6
1101.54	O-RING - PLUNGER BOLT, INNER ^A	3	6063.P8	CRANKCASE ASSEMBLY	1
1101.F3	O-RING - SPLIT MANIFOLD	3	6061.A2	PLUNGER KIT (KIT 100)	1
1101.Q1	O-RING - BEARING FLANGE	4	6062.49	IN/OUTLET VALVE KIT (KIT 548)	1
1202.94	LEFT BASE PLATE	1	6062.50	WATER SEAL KIT (KIT 549)	1
1202.95	RIGHT BASE PLATE	1	6062.51	BRASS RING KIT (KIT 550)	1
1205.17	CERAMIC PLUNGER D50	3			
1219.15	PTO DRIVE SHAFT GUARD "UNIVERSAL"	1			
1221.20	PRESSURE RING D50 ^D	3			
1240.R9	LIFTING HOOK M10	1			

^A Parts in 6061.A2 (Kit 100).
^B Parts in 6062.49 (Kit 548).
^C Parts in 6062.50 (Kit 549).
^D Parts in 6062.51 (Kit 550).



GAMMA-IL 83/103 DIMENSIONS

WEIGHT 118 LBS
 LUBRICATION 128 OZ UDOR LUBE
 SHAFT OPTIONS
 TS1C ... 1-3/8" 6-Spline Male PTO x 35mm Solid Keyed Thru-Shaft
 TS2C 1-3/8" 6-Spline Male PTO Thru-Shaft

*Dimensional Drawings are
 Shown in Millimeters.
 To Convert to Inches,
 Multiply Dimension x 0.03937*

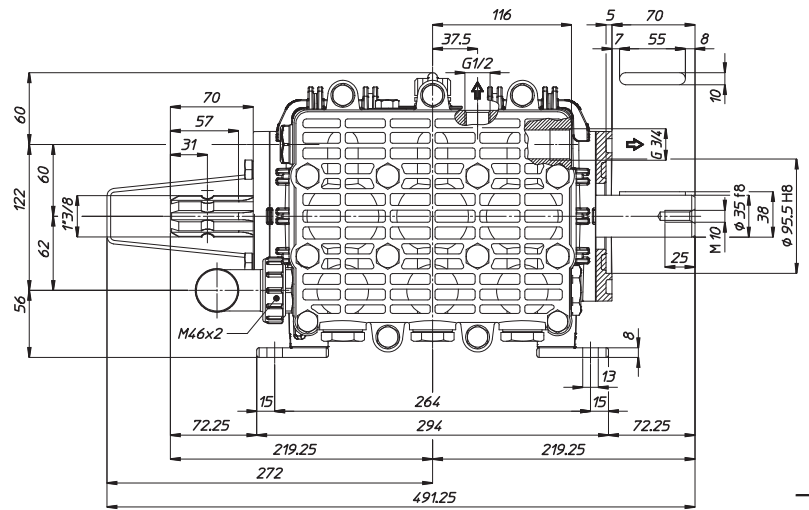
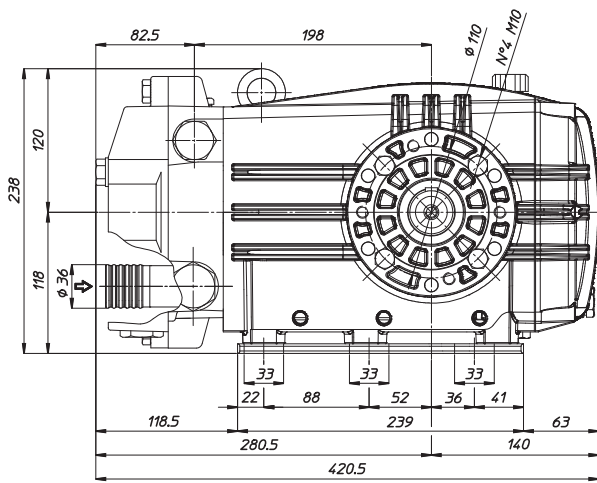

TORQUE SPECS

Ref.	Description	Ft./lb.	Nm	Loctite®
1	Head Bolts	66	90	-
2	Valve Caps	-	-	-
3	Inlet Cap	133	180	-
4	Outlet Cap	103	140	243
5	Bearing Flange Bolts	37	50	-
6	Rear Cover Bolts	8	11	-
7	Connecting Rod Bolts	19	25	243
8	Plunger Bolts	48	65	243
9	Valve Cover Bolts	-	-	-
10	Oil Drain Plug	8	11	-

