



GAMMA 85 SERIES

1-3/8" 6 Spline PTO Thru Shaft

Multiple Drive Options Available
600 RPM



- Anodized Aluminum Crankcase
- High Strength Aluminum Connecting Rods
- Solid Ceramic Plungers
- Stainless Steel Check Valves
- 1-1/2" Hose Barb Inlet.
- (2) 3/4" BSP-F Outlet
- 128 oz. Capacity Vented Oil Bath Crank Case
- Max Fluid Temp, 160°F

TS 1C
1-3/8" PTO x
35mm Keyed



TS 2C
1-3/8" PTO x
1-3/8" PTO



GAMMA 85 Series Plunger Pumps

GAMMA 85 Series industrial duty plunger pumps are rated at 22.5 GPM and pressures up to 870 PSI.

Pumps are available with a 1-3/8" male PTO through shaft with the option of a 2nd 1-3/8" male PTO shaft or a 35mm solid, keyed shaft.

Applications include fire fighting,, construction, de-icing and orchard spraying.

	Model	Flow		Pressure		Plunger Dia.	Crankshaft		Power	Seal Kit	Valve Kit	Wt.
		GPM	l/min	PSI	bar		Stroke	Code				
600 RPM	GAMMA 85 TS 1C	22.5	85.0	870	60	50mm	24.0mm	N	13.5 EBHP	6062.50	6062.49	83 lbs
	GAMMA 85 TS 2C	22.5	85.0	870	60	50mm	24.0mm	N	13.5 EBHP	6062.50	6062.49	83 lbs



6180 140th Avenue NW
Ramsey, MN 55303

Ph: 651-785-0666
Fax: 800-732-2670

www.udorusa.com
www.boominator.com
info@udorusa.com



Scan this QR Code
for More Information

G85TS
2024A

MAX FLOW 22.5 GPM / 85.0 L/MIN
MAX PRESSURE 870 PSI / 60 BAR
RATED PUMP SPEED 600 RPM
POWER REQUIREMENT 13.5 HP ELECTRIC
LUBRICATION 128 OZ UDOR LUBE

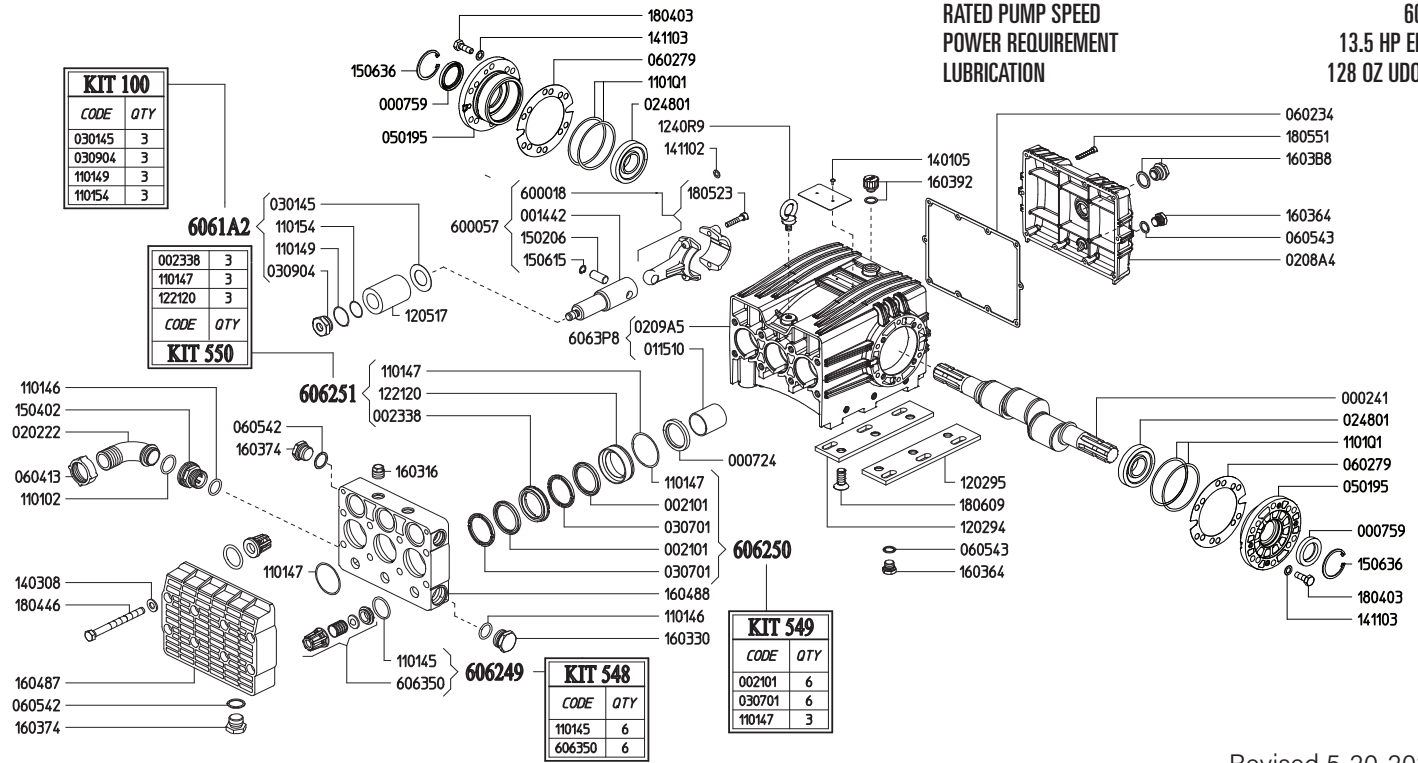

Revised 5-20-2022

Part #	Description	Qty	Part #	Description	Qty
0002.41	SHAFT TS 2C	1	1240.R9	LIFTING HOOK M10	1
0007.24	OIL SEAL D40	3	1401.05	RIVET UNI7346-3,5X8	2
0007.59	OIL SEAL D35	2	1403.08	WASHER D13	8
0014.42	PLUNGER GUIDE	3	1411.02	SERATED WASHER D8	6
0021.01	PISTON SEAL RING D50 ^C	6	1411.03	SERATED WASHER D10	8
0023.38	UPPER RING D50 ^D	3	1502.06	PIN D15X32.3	3
0115.10	BUSHING D40	3	1504.02	BRASS INLET CONNECTOR	1
0202.22	HOSE BARB D36	1	1506.15	SNAP RING D15	3
0208.A4	BACK COVER	1	1506.36	SNAP RING D55	2
0209.A5	CRANKCASE	1	1603.16	PLUG G1/2	2
0248.01	ROLLER BEARING D35	2	1603.30	PLUG G1"	1
0301.45	DISC ^A	3	1603.64	PLUG G3/8	2
0307.01	SPACER RING D50 ^B	6	1603.74	PLUG G3/4	3
0309.04	NUT D50 ^A	3	1603.92	OIL PLUG G1/2	1
0501.95	BEARING FLANGE	2	1603.B8	OIL PLUG G3/4 + GASKET	1
0602.34	BACK COVER GASKET	1	1604.87	FRONT HEAD	1
0602.79	FLANGE GASKET	2	1604.88	MIDDLE HEAD	1
0604.13	BRASS NUT M46X2	1	1804.03	HEX BOLT M10X30	8
0605.42	GASKET D27	3	1804.46	HEX BOLT M12X130	8
0605.43	GASKET D17	2	1805.23	ALLEN BOLT M8X40	6
1101.02	O-RING - INLET HOSE BARB	1	1805.51	ALLEN BOLT M6X40	10
1101.45	O-RING - VALVE ^B	6	1806.09	SCREW M14X35	6
1101.46	O-RING - INLET PORT	2	6000.18	ROD ASSEMBLY	3
1101.47	O-RING - SPLIT MANIFOLD	3	6063.50	VALVE ASSEMBLYW/O O-RING ^B	6
1101.47	O-RING - PRESSURE RING ^{C D}	3	6063.P8	CRANKCASE ASSEMBLY	1
1101.49	O-RING - PLUNGER BOLT OUTER ^A	3	6061.A2	PLUNGER KIT (KIT 100)	1
1101.54	O-RING - PLUNGER BOLT INNER ^A	3	6062.49	IN/OUTLET VALVE KIT (KIT 548)	1
1101.Q1	O-RING - BEARING FLANGE	4	6062.50	WATER SEAL KIT (KIT 549)	1
1202.94	LEFT BASE PLATE	1	6062.51	BRASS RING KIT (KIT 550)	1
1202.95	RIGHT BASE PLATE	1			
1205.17	CERAMIC PLUNGER D50	3			
1221.20	PRESSURE RING D50 ^D	3			

^A Parts in 6061.A2 (Kit 100).

^B Parts in 6062.49 (Kit 548).

^C Parts in 6062.50 (Kit 549).

^D Parts in 6062.51 (Kit 550).



GAMMA 85/105/125 DIMENSIONS

WEIGHT 83 LBS
 LUBRICATION 128 OZ UDOR LUBE
 SHAFT OPTIONS
 TS1C ... 1-3/8" 6-Spline Male PTO x 35mm Solid Keyed Thru-Shaft
 TS2C 1-3/8" 6-Spline Male PTO Thru-Shaft

*Dimensional Drawings are
 Shown in Millimeters.
 To Convert to Inches,
 Multiply Dimension x 0.03937*

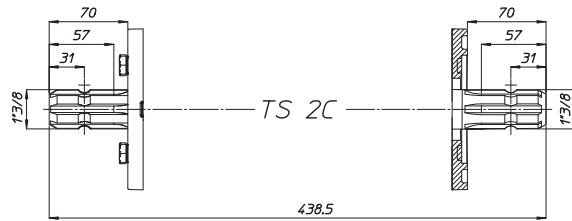
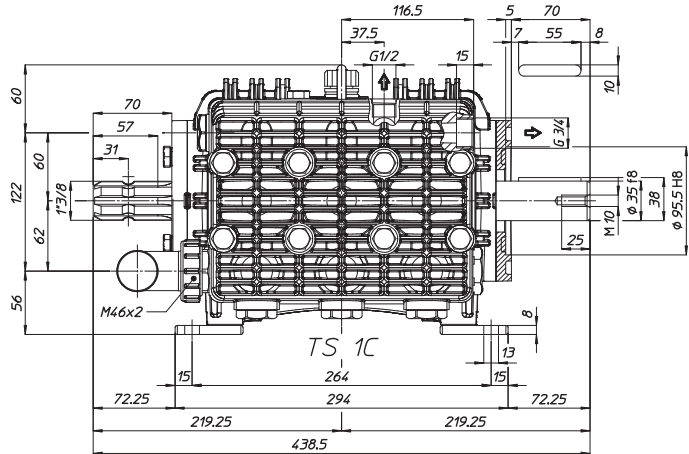
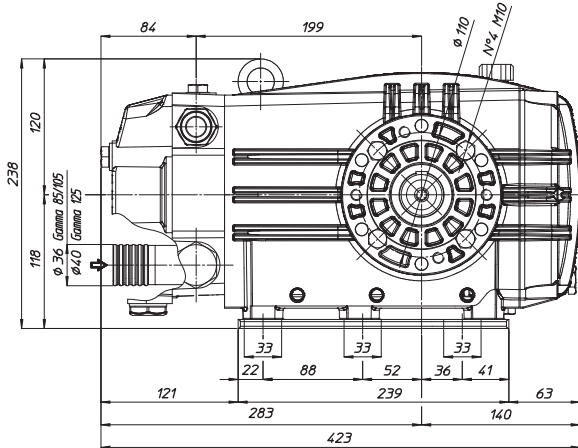

TORQUE SPECS

Ref.	Description	Ft./lb.	Nm	Loctite®
1	Head Bolts	66	90	-
2	Valve Caps	-	-	-
3	Inlet Cap	133	180	-
4	Outlet Cap	103	140	243
5	Bearing Flange Bolts	37	50	-
6	Rear Cover Bolts	8	11	-
7	Connecting Rod Bolts	19	25	243
8	Plunger Bolts	48	65	243
9	Valve Cover Bolts	-	-	-
10	Oil Drain Plug	8	11	-

