

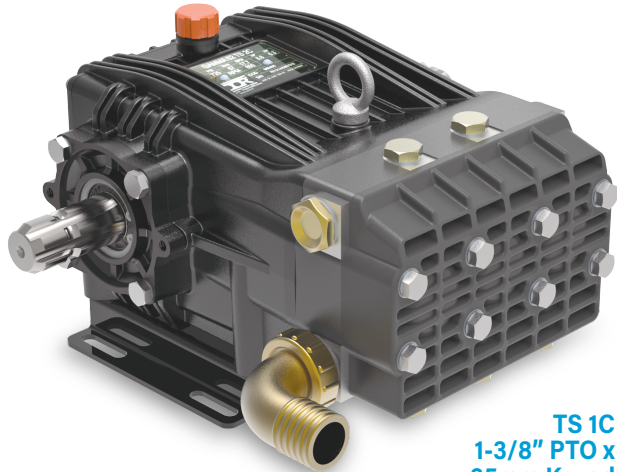

GAMMA 62 SERIES

1-3/8" 6 Spline PTO Thru Shaft

Multiple Drive Options Available
600 RPM



- Anodized Aluminum Crankcase
- Solid Ceramic Plungers
- Stainless Steel Check Valves
- High Strength Aluminum Connecting Rods
- 1-1/4" Hose Barb Inlet. (2) 3/4" BSP-F Outlet
- 57.6 oz. Capacity Vented Oil Bath Crank Case
- Max Fluid Temp, 160°F

TS 1C
1-3/8" PTO x
35mm Keyed



TS 2C
1-3/8" PTO x
1-3/8" PTO



TS GR
GR Model
Replacement

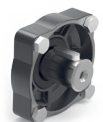

GAMMA 62 Series Plunger Pumps

GAMMA 62 Series industrial duty plunger pumps are rated at 17.7 GPM and pressures up to 725 PSI.

Pumps are available with a 1-3/8" male PTO through shaft with the option of a 2nd 1-3/8" male PTO shaft, 35mm solid, keyed shaft or short shaft for direct GR version replacement

Applications include general pressure cleaning,, construction, de-icing and orchard spraying.

	Model	Flow		Pressure		Plunger Dia.	Crankshaft		Power	Seal Kit	Valve Kit	Wt.
		GPM	l/min	PSI	bar		Stroke	Code				
600 RPM	GAMMA 62 TS 1C	17.7	670	725	50	40mm	30.0mm	F	8.6 EBHP	6062.A1	6062.65	49 lbs
	GAMMA 62 TS 2C	17.7	670	725	50	40mm	30.0mm	F	8.6 EBHP	6062.A1	6062.65	49 lbs
	GAMMA 62 TS GR	17.7	670	725	50	40mm	30.0mm	F	8.6 EBHP	6062.A1	6062.65	49 lbs



6180 140th Avenue NW
Ramsey, MN 55303

Ph: 651-785-0666
Fax: 800-732-2670

www.udorusa.com
www.boominator.com
info@udorusa.com



Scan this QR Code
for More Information

G62TS
2024A

MAX FLOW
MAX PRESSURE
RATED PUMP SPEED
POWER REQUIREMENT
LUBRICATION

17.7 GPM / 67.0 L/MIN
725 PSI / 50 BAR
600 RPM
8.6 HP ELECTRIC
57.6 OZ UDOR LUBE

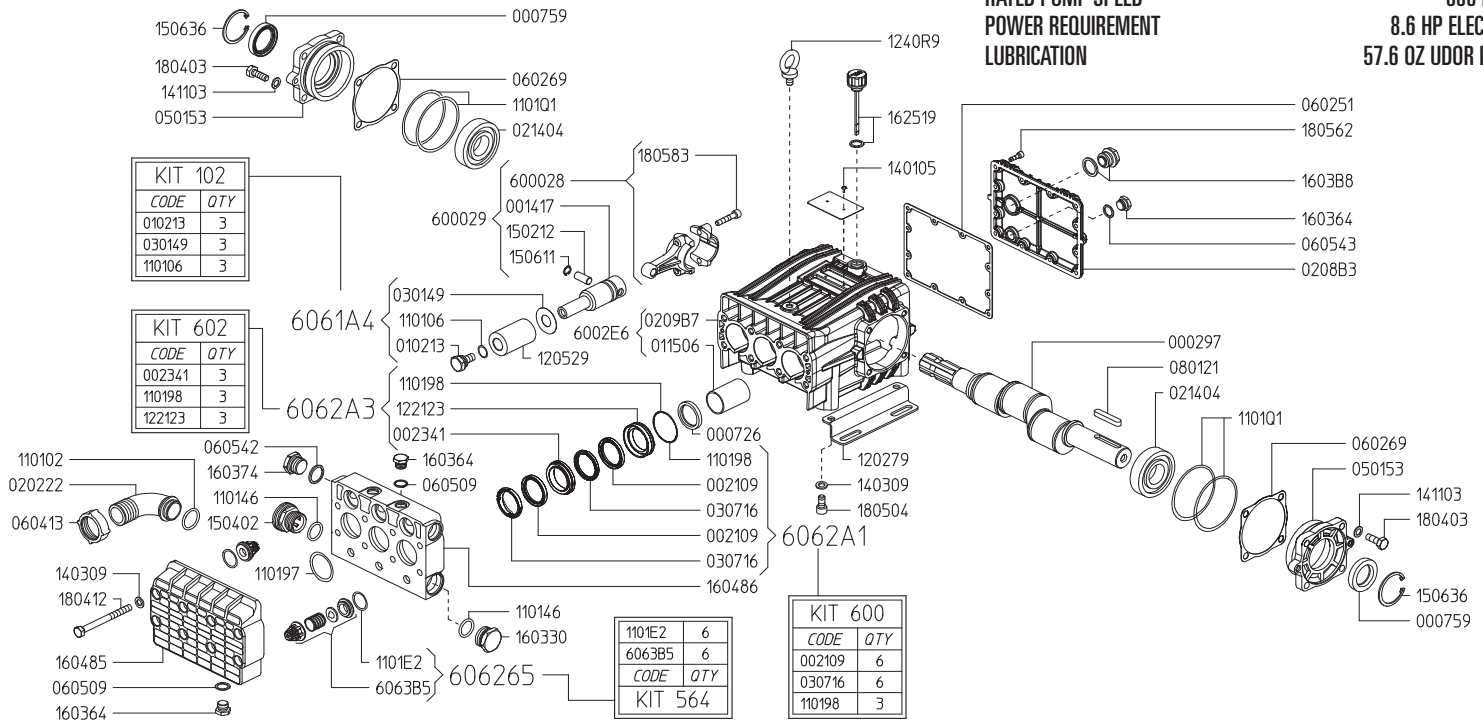

Revised 11-30-2023

Part #	Description	Qty	Part #	Description	Qty
0002.97	SHAFT TS1C	1	1240.R9	LIFTING HOOK M10	1
0007.26	OIL SEAL D35	3	1401.05	RIVET 3.5X8	2
0007.59	OIL SEAL D35	2	1403.09	WASHER D10.5	12
0014.17	PLUNGER GUIDE	3	1411.02	SERATED WASHER D8	6
0021.09	WATER SEAL H.P. D40 ^C	6	1411.03	SERATED WASHER D10	8
0023.41	UPPER RING D40 ^D	3	1502.12	PIN D12X27.8	3
0102.13	PISTON BOLT ^A	3	1504.02	BRASS INLET CONNECTOR	1
0115.06	BUSHING D35	3	1506.11	SNAP RING D12	3
0202.22	HOSE BARB D36	1	1506.36	SNAP RING D55	2
0208.B3	BACK COVER	1	1603.30	PLUG G1"	1
0209.B7	CRANKCASE	1	1603.64	PLUG G3/8	5
0214.04	BALL BEARING D35	2	1603.74	PLUG G3/4	1
0301.49	DISC ^A	3	1603.B8	OIL PLUG G3/4 + GASKET	1
0307.16	SPACER RING D40 ^C	6	1604.85	FRONT HEAD	1
0501.53	BEARING FLANGE	2	1604.86	MIDDLE HEAD	1
0602.51	BACK COVER GASKET	1	1625.19	OIL PLUG G1/2 + GASKET	1
0602.69	FLANGE GASKET	2	1804.03	HEX BOLT M10X30	8
0604.13	BRASS NUT M46X2	1	1804.12	HEX BOLT M10X110	8
0605.09	GASKET D17	4	1805.04	ALLEN BOLT M10X20	4
0605.42	GASKET D27	1	1805.23	ALLEN BOLT M8X40	6
0605.43	GASKET D17	1	1805.62	ALLEN BOLT M6X20	12
0801.21	KEY A10X8X50 UNI6604	1	6000.28	ROD ASSEMBLY	3
1101.02	O-RING - INLET HOSE BARB	1	6002.E6	CRANKCASE ASSEMBLY	1
1101.06	O-RING - PLUNGER BOLT ^A	3	6063.B5	VALVE ASSEMBLY W/O O-RING ^B	6
1101.46	O-RING - INLET PORT	2	6061.A4	PLUNGER KIT(KIT 102)	1
1101.97	O-RING - SPLIT MANIFOLD	3	6062.65	IN/OUTLET VALVE KIT (KIT 564)	1
1101.98	O-RING - PRESSURE RING ^{C,D}	3	6062.A1	WATER SEAL KIT (KIT 600)	1
1101.E2	O-RING - VALVE ^B	6	6062.A3	BRASS RING KIT (KIT 602)	1
1101.Q1	O-RING - BEARING FLANGE	4			
1202.79	BASE PLATE	2			
1205.29	CERAMIC PLUNGER D40	3			
1221.23	PRESSURE RING D40 ^D	3			

^A Parts in 6061.A4 (Kit 102).
^B Parts in 6062.65 (Kit 564).
^C Parts in 6062.A1 (Kit 600).
^D Parts in 6062.A3 (Kit 602).

GAMMA 62 DIMENSIONS

WEIGHT 49 LBS
 LUBRICATION 57.6 OZ UDOR LUBE
 SHAFT OPTIONS
 TS1C ... 1-3/8" 6-Spline Male PTO x 35mm Solid Keyed Thru-Shaft
 TS2C 1-3/8" 6-Spline Male PTO Thru-Shaft
 TSGR Replacement for GR Models

*Dimensional Drawings are
 Shown in Millimeters.
 To Convert to Inches,
 Multiply Dimension x 0.03937*

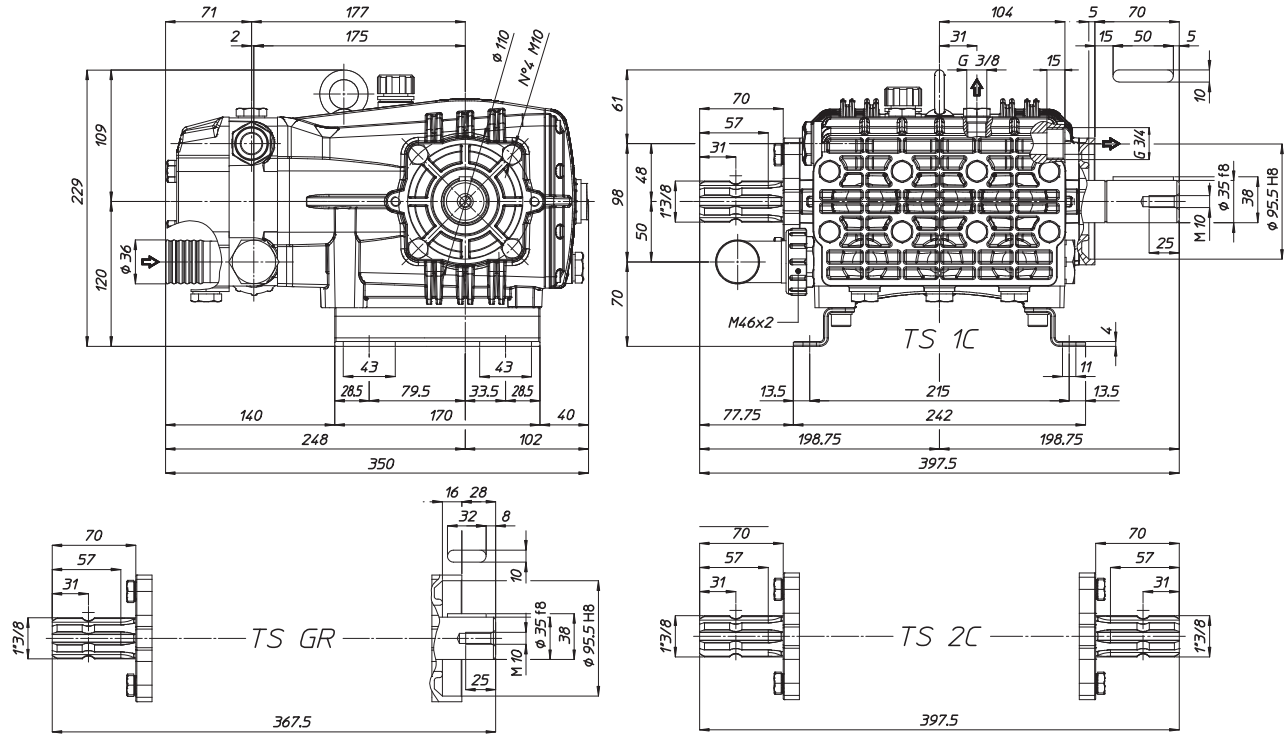

TORQUE SPECS

Ref.	Description	Ft./lb.	Nm	Loctite®
1	Head Bolts	37	50	-
2	Valve Caps	-	-	-
3	Inlet Cap	133	180	-
4	Outlet Cap	103	140	243
5	Bearing Flange Bolts	37	50	-
6	Rear Cover Bolts	8	11	-
7	Connecting Rod Bolts	19	25	243
8	Plunger Bolts	37	50	243
9	Valve Cover Bolts	-	-	-
10	Oil Drain Plug	8	11	-

