

## 2-Cylinder, Medium-Pressure Diaphragm Pumps

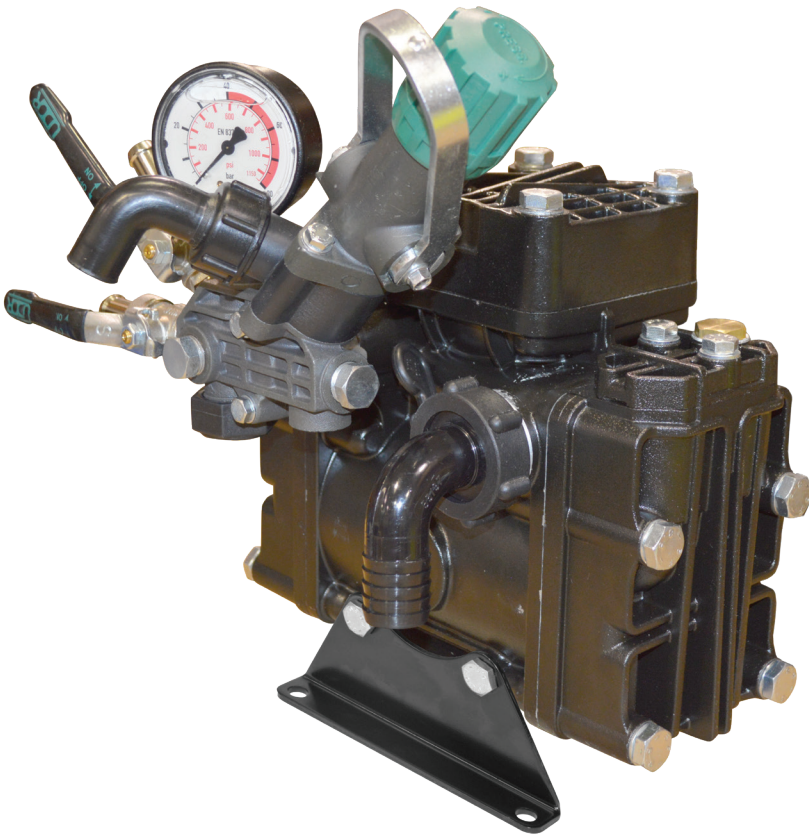

DELTA 40 2-cylinder, medium pressure diaphragm pumps are internally manifolded with anodized aluminum construction and anodized aluminum and stainless steel liquid handling parts.

DELTA 40 pumps are excellent choices for various horticultural, agricultural, lawn care, nursery, pest control and turf spraying applications. They are also effectively used for aircraft de-icing, hydrostatic testing and cleaning applications.

Model	GPM	l/min	PSI	bar	RPM	Drive Configuration	Weight
DELTA 40	10.5	40.0	560	40	550	25 mm Solid Keyed Shaft. Mounting Rails	29 LBS
DELTA 40 TSFVA	10.5	40.0	560	40	550	25 mm Solid Keyed Shaft x Universal VA Drive Face. Mounting Rails	29 LBS
DELTA 40 GR3/4	10.5	40.0	560	40	550	Gear Reduction for 3/4" Shaft Gas Engine, 4-6.5 HP	39 LBS

Specifications	DELTA 40	Description	Part #
Inlet Port	1" Hose Barb	Diaphragm Kit (GREENTECH)	6062.G4
Outlet Ports	(2) 1/2" Hose Barb	Diaphragm Bolt/Washer Kit	6062.B4
Bypass	3/4" Hose Barb	Valve Kit	6062.G3
Piston Diameter	55mm	Regulator Repair Kit	6062.A9
Crankshaft Stroke/Code	15.0mm / T	Complete Repair Kit	8700.85CK
Dimensions	10.5"L x 11.5"W x 10.5"H		

**Lubrication:** Requires 20 oz. of Udor Lube 40W Premium Pump Oil.  
Alternate Oil: 30W non-detergent or 15W-40 non-detergent oil.



6062B4 KIT 612		6062G3 KIT 663		6062G4 KIT 664		8700.85CK	
CODE	QTY	CODE	QTY	CODE	QTY	CODE	QTY
010204	2	110131	4	090314	1	010204	2
030143	2	606304	4	090320	2	030143	2
				1101B8	4	090320	2
						110131	4
						110141	1
						110195	4
						1101B8	4
						606304	4

Maximum Flow	10.5 GPM / 40 lpm
Maximum Pressure	560 PSI / 40 bar
Maximum RPM	540
Inlet Port - Hose Barb	1" HB
Outlet Ports - Hose Barb, Valve	(2) 1/2" HB
Bypass - Hose Barb	3/4" HB
Dimensions	10.5"L x 11.5"W x 10.5"H
Weight	29 lbs

**Lubrication:** Requires 20 oz. of Udor Lube 40W Premium Pump Oil.  
Alternate Oil: 30W non-detergent or 15W-40 non-detergent oil.

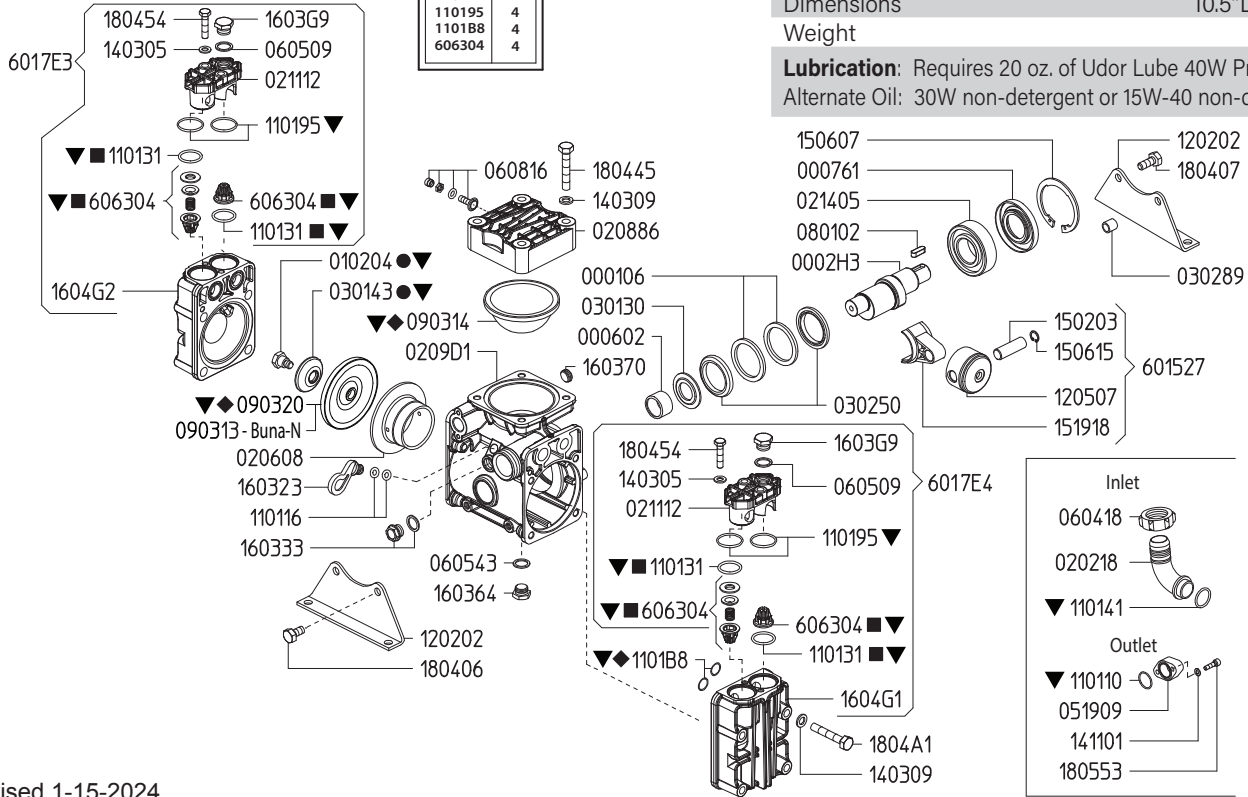

Revised 1-15-2024

Part #	Description	Qty	Part #	Description	Qty
0001.06	RETAINER RING	2	1403.05	WASHER M8	4
0002.H3	SHAFT "DELTA 40"	1	1403.09	WASHER M10	12
0006.02	BUSHING D25	1	1411.01	SERATED WASHER M6	2
0007.61	OIL SEAL D35	1	1502.03	PIN D15X48	2
0102.04	DIAPHRAGM BOLT ●▼	2	1506.07	SNAP RING D72	1
0202.18	HOSE BARB D25 ( 1" )	1	1506.15	SNAP RING D15	2
0206.08	SLEEVE D55	2	1519.18	CONNECTING ROD	2
0209.D1	CRANKCASE	1	1603.23	OIL PLUG W/O O-RINGS	1
0211.12	VALVE COVER	2	1603.33	PLUG G3/8+GASKET	1
0214.05	BALL BEARING D35	1	1603.64	PLUG G3/8	1
0301.30	BEARING DISC	1	1603.70	PLUG G3/8	1
0301.43	DIAPHRAGM DISC ●▼	2	1603.G9	HEAD PLUG 3/8	2
0302.50	ROD SPACER	2	1604.G1	RIGHT HEAD	1
0302.89	SPACER	2	1604.G2	LEFT HEAD	1
0519.09	REMOTE CONTROL FLANGE G1/2	1	1804.06	HEX BOLT M10X20	2
0604.18	BARB NUT M42X2	1	1804.07	HEX BOLT M10X25	2
0605.09	GASKET D17	2	1804.45	HEX BOLT M10X60	4
0605.43	GASKET D17	1	1804.54	HEX BOLT M8X35	4
0608.16	AIR VALVE ASSEMBLY	1	1804.A1	HEX BOLT M10X70	8
0801.02	KEY A8X7X25	1	1805.53	ALLEN BOLT M6X22	2
0903.13	PISTON DIAPHRAGM D100 BUNA-N	2	6015.27	ROD ASSEMBLY D55	2
0903.14	ACCUMULATOR DIAPHRAGM ◆▼	1	6017.E3	HEAD ASSEMBLY - LEFT	1
0903.20	PISTON DIAPHRAGM D100 GREENTECH ◆▼	2	6017.E4	HEAD ASSEMBLY - RIGHT	1
1101.10	O-RING - DISCHARGE PORT	1	6063.04	VALVE ASSEMBLY W/O O-RING ■▼	4
1101.16	O-RING - OIL PLUG	2	6062.B4	DIAPHRAGM BOLT / WASHER KIT (KIT 612)	1
1101.31	O-RING - VALVE ■▼	4	6062.G3	IN/OUTLET VALVE KIT (KIT 663)	1
1101.41	O-RING - INLET HOSE BARB ▼	1	6062.G4	DIAPHRAGM KIT - GREENTECH (KIT 664)	1
1101.95	O-RING - VALVE COVER ▼	4	8700.85CK	COMPLETE REPAIR KIT	1
1101.B8	O-RING - HEAD ◆▼	4			
1202.02	BASE PLATE	2			
1205.07	ALUMINIUM PISTON D55	2			

- Parts in 6062.B4 (Kit 612)
- Parts in 6062.G3 (Kit 663)
- ◆ Parts in 6062.G4 (Kit 664)
- ▼ Parts in 8700.85CK (Complete Repair Kit)

# 6010.24 & 6010.24/LP

## Adjustable Pressure Regulators

606253		606255	
KIT 552		KIT 554	
Optional ▲		■	
CODE	QTY	CODE	QTY
090326	1	090326	1
110104	1	110104	1
110112	2	110106	2
110141	1	110112	2
120419	1	110141	1
150123	1	150123	1
181001	1	870104	1

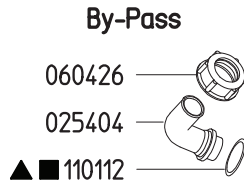

6010.24	Maximum Flow	27.0 GPM / 102 lpm
	Maximum Pressure	560 PSI / 38 bar
6010.24/LP	Maximum Flow	27.0 GPM / 102 lpm
	Maximum Pressure	350 PSI / 24 bar
Inlet Port - Hose Barb		-
Outlet Ports - Hose Barb, Valve		(2) 1/2" HB
Bypass - Hose Barb		3/4" HB

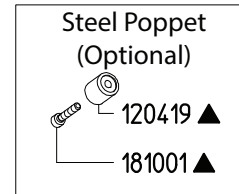
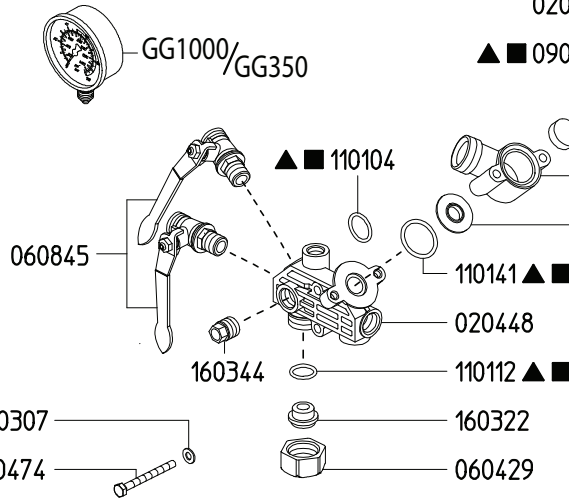
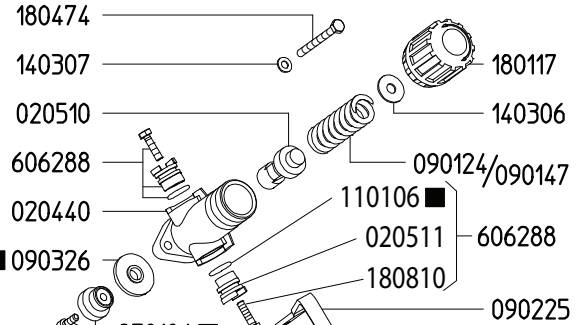
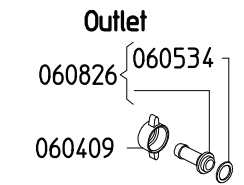

Revised 1-15-2024

Part #	Description	Qty
0202.25	BYPASS HOSE BARB - STRAIGHT (OPTIONAL)	1
0204.40	VALVE BODY	1
0204.48	MAIN BODY	1
0205.10	VALVE CYLINDER	1
0205.11	VALVE CYLINDER CAM	2
0254.04	BYPASS HOSE BARB - ELBOW	1
0604.09	DISCHARGE BARB NUT	2
0604.26	BYPASS BARB NUT	1
0604.29	BARB NUT	1
0605.34	GASKET	2
0608.26	1/2" HOSE BARB W/GASKET	2
0608.45	BALL VALVE; RIGHT	2
0901.24	HIGH PRESSURE SPRING "6010.24"	1
0901.47	LOW PRESSURE SPRING "6010.24/LP"	1
0902.25	DUMP VALVE LEVER	1
0903.26	DIAPHRAGM ▲■	1
1101.04	O-RING ▲■	1
1101.06	O-RING ■	2
1101.12	O-RING ▲■	2
1101.41	O-RING ▲■	1

Part #	Description	Qty
1203.41	BODY	1
1204.19	STEEL POPPET - OPTIONAL ▲	1
1403.06	WASHER	1
1403.07	WASHER	4
1501.23	SEAT ▲■	1
1603.22	PLUG	1
1603.44	PLUG	2
1801.17	ADJUSTMENT KNOB	1
1804.74	BOLT	4
1808.10	BOLT	2
1810.01	STAINLESS STEEL BOLT - OPTIONAL ▲	1
6062.88	REGULATOR CAM KIT	2
8701.04	URETHANE POPPET ASSEMBLY ■	1
GG1000	HIGH PRESSURE GAUGE - 1000 PSI "6010.24"	1
GG350	LOW PRESSURE GAUGE - 350 PSI "6010.24/LP"	1
6062.53	REPAIR KIT - STEEL POPPET (KIT 552) OPTIONAL	1
6062.55	REPAIR KIT - 6010.24/LP (KIT 554)	1

▲ Parts Included in Repair Kit 6062.53 (KIT 552)  
 ■ Parts Included in Repair Kit 6062.55 (KIT 554)

- Before operating or re-operating the pump, push the manual dump valve lever (0902.25) down, so the pump will start at zero pressure. FAILURE TO DO SO WILL VOID PUMP WARRANTY.
- Turn pressure adjustment knob (1801.17) counterclockwise to relieve spring tension. NOTE: Step 2 applies only to initial start-up, and is not necessary in daily operation of pump.
- Start unit and let run until air is evacuated from system, when only liquid is expelled from the bypass line.
- Return dump valve lever to the UP position. Open spray gun or spray boom and turn the pressure adjustment knob (1801.17) clockwise until desired operating pressure is achieved.

All Dimensions are WITHOUT Control Unit or Regulator

Dimensional Drawings are Shown in Millimeters. To Convert to Inches, Multiply Dimension x 0.03937

## Specifications

## DELTA 40

Inlet Port - Hose Barb	1" HB
Outlet Ports - Hose Barb	(2) 1/2" HB
Bypass - Hose Barb	3/4" HB
Dimensions	10.5"L x 11.5"W x 10.5"H
Diaphragm Material	GREENTECH (Std) Buna-N (Opt)

**Lubrication:** Requires 20 oz. of Udor Lube 40W Premium Pump Oil.  
Alternate Oil: 30W non-detergent or 15W-40 non-detergent oil.

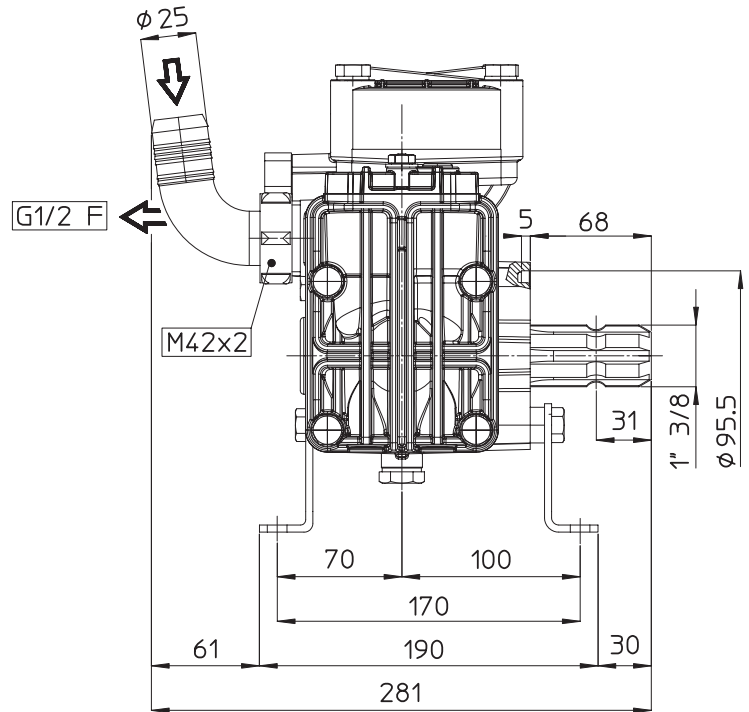
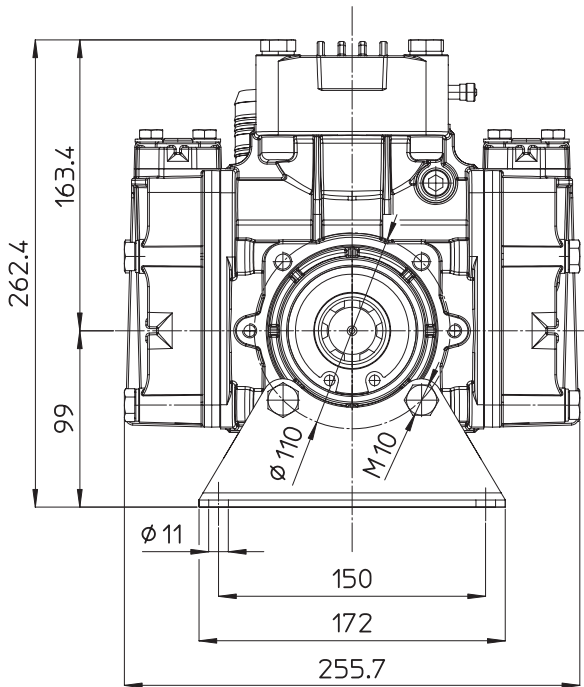

## TORQUE SPECS

Ref.	Description	Ft./lb.	Nm
1	Diaphragm Bolts (Use Loctite 243)	18	25
2	Head Bolts	30	40
3	Pulsation Dampener Bolts	20	28
4	Inlet Flange Bolts	-	-
5	Bearing Flange Bolts	25	34
6	Oil Cup Bolts	-	-
7	Valve Cover Bolts	-	-

