

4-Cylinder, High-Pressure Diaphragm Pumps



DELTA 170 4-cylinder, high pressure diaphragm pumps are internally manifolded with anodized aluminum construction and anodized aluminum and stainless steel liquid handling parts. Includes mounting rails and 6005.05 control unit with pressure gauge.

DELTA 170 pumps are excellent choices for various horticultural, agricultural, lawn care, nursery, pest control and turf spraying applications. They are also effectively used for aircraft de-icing, hydrostatic testing and cleaning applications.

Model	GPM	l/min	PSI	bar	RPM	Drive Configuration	Weight
DELTA 170 TS2C	47.3	179.5	725	49	550	1-3/8" 6-Spline Male PTO Thru-Shaft	110 LBS
DELTA 170 TSMFVA	47.3	179.5	725	49	550	1-3/8" 6-Spline PTO x Universal VA Drive Face	110 LBS
DELTA 170 GR1-1/8	47.3	179.5	725	49	550	Gear Reduction for 1-1/8" Shaft Gas Engines, 24-31 HP	130 LBS
DELTA 170 GR ASSY	47.3	179.5	725	49	550	Pump, Gear Reduction, 31 HP Gas Engine, Base	320 LBS

Specifications	DELTA 170	Description	Part #
Inlet Port	1-1/2" Hose Barb	Diaphragm Kit (GREENTECH)	6062.H7
Outlet Ports	(2) 1/2" Hose Barb	Diaphragm Bolt / Washer Kit	606224
Bypass	1" Hose Barb	Valve Kit	6062.H8
Piston Diameter	75mm	Complete Repair Kit	8700.84CK
Crankshaft Stroke/Code	19.0mm / U		
Dimensions	15.5"L x 21.5"W x 16.5"H		

Lubrication: Requires 66 oz. of Udor Lube 40W Premium Pump Oil.
Alternate Oil: 30W non-detergent or 15W-40 non-detergent oil.



Maximum Flow	47.3 GPM / 179.2 lpm
Maximum Pressure	725 PSI / 50 bar
Maximum RPM	550 RPM
Inlet Port	1-1/2" Hose Barb
Outlet Ports	(2) 1/2" Hose Barb Valve, 3/4" MPT
Bypass	1" Hose Barb
Dimensions	15.5" L x 21.5" W x 16.5" H
Weight	110 lbs

Lubrication: Requires 66 oz. of Udor Lube 40W Premium Pump Oil.
Alternate Oil: 30W non-detergent or 15W-40 non-detergent oil.

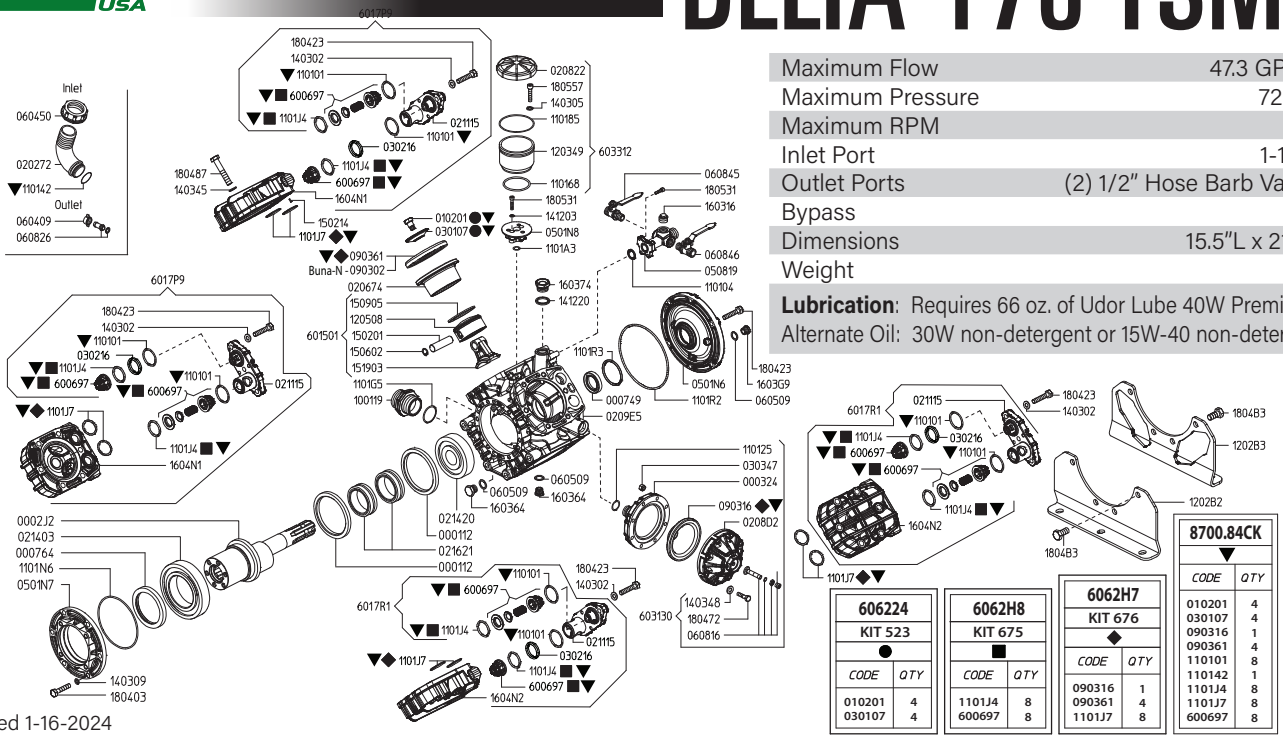

Revised 1-16-2024

Part #	Description	Qty	Part #	Description	Qty
0001.12	RETAINER RING "DELTA 140/170"	2	1101.R2	O-RING - CRANKCASE FLANGE	1
0002.J2	SHAFT "DELTA 140/170" TS MFVA	1	1101.R3	O-RING - CRANKCASE FLANGE	1
0003.24	PRESSURE ACCUMULATOR	1	1202.B2	BASE PLATE "DELTA 170"	1
0007.49	OIL SEAL D35	1	1202.B3	BASE PLATE "DELTA 170"	1
0007.64	OIL SEAL D75	1	1203.49	OIL RESERVOIR "BETA"	1
0102.01	DIAPHRAGM BOLT ●▼	4	1205.08	ALUMINIUM PISTON D75	4
0202.72	HOSE BARB D40	1	1403.02	WASHER D10.5	12
0206.74	SLEEVE "DELTA 140/170"	4	1403.05	WASHER D8.4	3
0208.22	OIL RESERVOIR COVER	1	1403.09	WASHER D10.5	6
0208.D2	ACCUMULATOR COVER	1	1403.45	WASHER D13	24
0209.E5	PUMP BODY	1	1403.48	WASHER D8.4 DACROMET	8
0211.15	VALVE COVER	4	1412.03	WASHER	2
0214.03	BALL BEARING D75	1	1412.20	WASHER	1
0214.20	BALL BEARING D35	1	1502.01	PIN D18X64	4
0216.21	ROLLER BEARING D35	2	1502.14	PIN	4
0301.07	DIAPHRAGM DISC ●▼	4	1506.02	SNAP RING D18	4
0302.16	SPACER	4	1509.05	PISTON RING D75	4
0303.47	HEX NUT M8X8	8	1519.03	CONNECTING ROD	4
0501.N6	CRANKCASE FLANGE	1	1603.16	PLUG G1/2	1
0501.N7	CRANKCASE FLANGE - MFVA	1	1603.64	OIL PLUG	2
0501.N8	FLANGE - OIL BOWL	1	1603.74	PLUG	1
0508.19	BALL VALVE FLANGE "DELTA 140/170"	1	1604.N1	RIGHT HEAD "DELTA 140/170"	2
0604.09	BRASS NUT G1/2	1	1604.N2	LEFT HEAD "DELTA 140/170"	2
0604.50	BARB NUT G1-1/2"	1	1804.03	HEX BOLT M10X30	6
0605.09	GASKET D17	2	1804.23	HEX BOLT M10X40	18
0608.16	AIR VALVE ASSEMBLY	1	1804.72	HEX BOLT M8X50	8
0608.26	HOSE BARB D13+GASKET	1	1804.87	HEX BOLT	24
0608.45	BALL VALVE RIGHT	1	1804.B3	HEX BOLT	8
0608.46	BALL VALVE LEFT	1	1805.31	ALLEN BOLT M6X30	6
0903.02	PISTON DIAPHRAGM 116MM BUNA-N	4	1805.57	ALLEN BOLT	3
0903.16	ACCUMULATOR DIAPHRAGM ◆▼	1	6006.97	VALVE ASSEMBLY W/O O-RING ■▼	8
0903.61	PISTON DIAPHRAGM 116MM GREENTECH ◆▼	4	6015.01	ROD ASSY "DELTA 140/170" D75	4
1001.19	INLET NIPPLE	1	6017.P9	HEAD ASSEMBLY - RIGHT	2
1101.01	O-RING - VALVE COVER ▼	8	6017.R1	HEAD ASSEMBLY - LEFT	2
1101.04	O-RING - BALL VALVE FLANGE	1	6031.30	PRESSURE ACCUMULATOR ASSEMBLY	1
1101.25	O-RING - ACUMULATOR	1	6033.12	OIL RESERVIOR ASSEMBLY	1
1101.42	O-RING - INLET HOSE BARB ▼	1	6062.H7	DIAPHRAGM BOLT / WASHER KIT (KIT 523)	1
1101.68	O-RING - OIL RESERVOIR	1	6062.H7	DIAPHRAGM KIT - GREENTECH (KIT 676)	1
1101.85	O-RING - OIL RESERVOIR	1	6062.H8	IN/OUT VALVE KIT (KIT 675)	1
1101.A3	O-RING - OIL RESERVOIR	1	8700.84CK	COMPLETE REPAIR KIT	1
1101.G5	O-RING - INLET NIPPLE	1	●	Parts in 6062.24 (Kit 523)	
1101.J4	O-RING - VALVE ■▼	8	◆	Parts in 6062.H7 (Kit 676)	
1101.J7	O-RING - HEAD, VITON ◆▼	8	■	Parts in 6062.H8 (Kit 675)	
1101.N6	O-RING - CRANKCASE FLANGE	1	▼	Parts in 8700.84CK (Complete Repair Kit)	

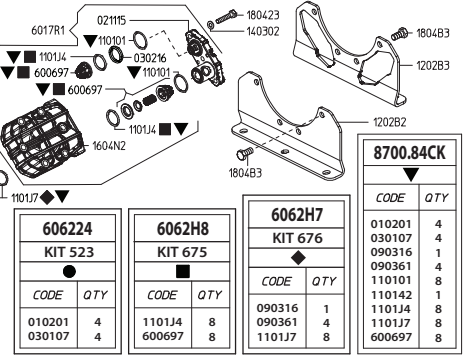

Kit Code	Kit Description	Code	Qty
606224	KIT 523	010201	4
6062H8	KIT 675	030107	4
6062H7	KIT 676	090316	1
		090361	4
		110101	8
		110142	1
		1101J4	8
		1101J7	8
		600697	8

Adjustable Pressure Regulator

Maximum Flow	47.3 GPM / 179.2 lpm
Maximum Pressure	1200 PSI / 81 bar
Inlet Ports	3/4" Male BSP
Outlet Ports	-
Bypass - Hose Barb	1" HB

606254	
KIT 553	
CODE	QTY
090325	1
110101	1
110131	1
120413	1
150125	1
181001	1

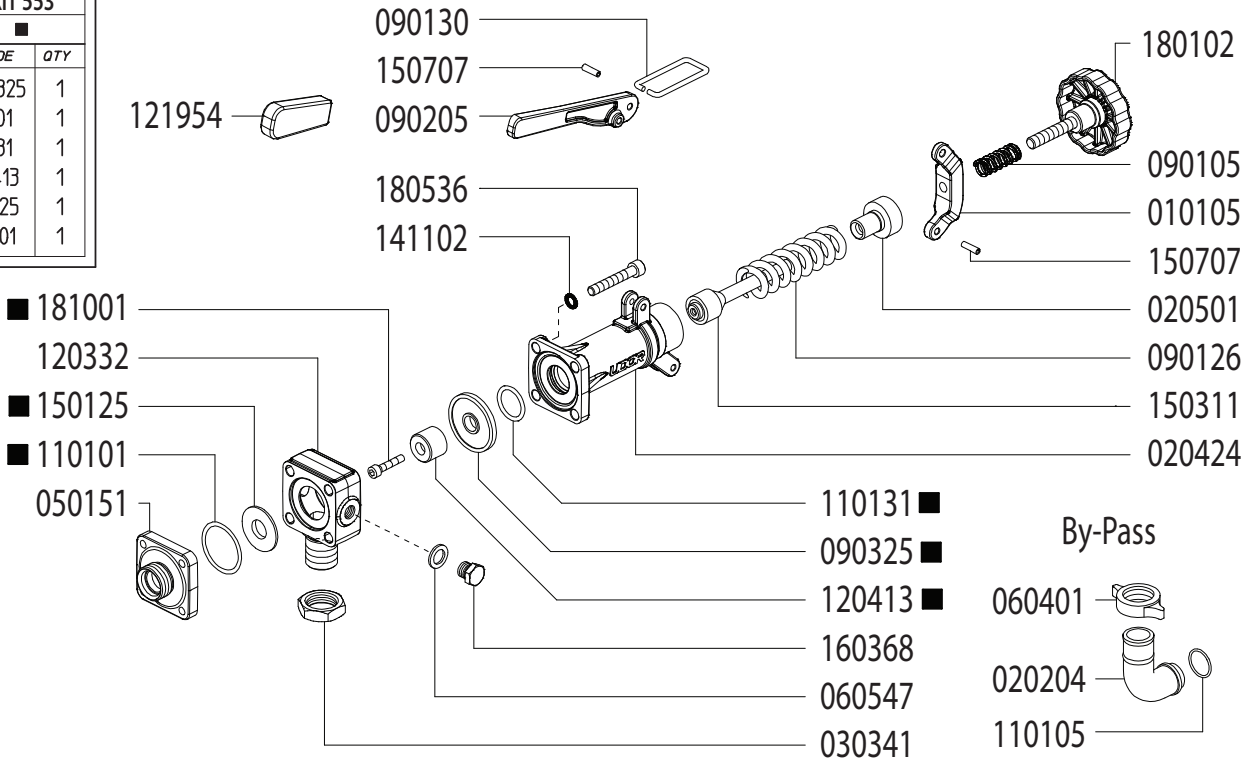

Revised 1-16-2024

Part #	Description	Qty
0101.05	LEVER GUIDE	1
0202.04	1" BRASS ELBOW HOSE BARB	1
0204.24	VALVE BODY	1
0205.01	VALVE CYLINDER	1
0303.41	NUT	1
0501.51	FLANGE	1
0604.01	BARB NUT	1
0901.05	SPRING	1
0901.30	PRESSURE BAIL	1
0901.26	SPRING	1
0902.05	HANDLE	1
0903.25	DIAPHRAGM	1
1101.01	O-RING - BYPASS FLANGE	1
1101.05	O-RING - BYPASS HOSE BARB	1

Part #	Description	Qty
1101.31	O-RING - VALVE BODY	1
1203.32	INLET ELBOW - 3/4" MALE BSP	1
1204.13	POPPET	1
1219.54	HANDLE COVER - RUBBER	1
1501.25	SEAT	1
1503.11	REGULATOR STEM	1
1507.07	PIN	2
1801.02	ADJUSTMENT KNOB	1
1805.36	BOLT	4
1810.01	BOLT - STAINLESS STEEL	1
GG1500	HIGH PRESSURE GAUGE (OPTIONAL)	1
6062.54	REPAIR KIT (KIT 553)	

■ Parts Included in Repair Kit #6062.54 (KIT 553)

OPERATING INSTRUCTIONS

- Before operating or re-operating pump, lift R.V. Handle (0902.05) so pump will start at zero pressure.
FAILURE TO DO SO WILL VOID PUMP WARRANTY.
- Turn Pressure Adjustment Knob (1801.02) counter-clockwise to relieve spring tension. (Step 2 is only necessary on initial start-up and is not necessary for daily operation.)
- Start unit and let run until air is evacuated from system, when only liquid is expelled from the bypass line.
- Return R.V. Handle (0902.05) to down position. Open spray gun or spray boom and turn adjustment knob (1801.02) clockwise until desired operating pressure is achieved.

All Dimensions are WITHOUT Control Unit or Regulator

Dimensional Drawings are Shown in Millimeters. To Convert to Inches, Multiply Dimension x 0.03937

Specifications

DELTA 170

Inlet Port - Hose Barb	1-1/4"HB
Outlet Ports - Hose Barb	(2) 1/2"HB
Bypass - Hose Barb	3/4" HB
Dimensions	15.5"L x 21.5"W x 16.5"H
Diaphragm Material	GREENTECH (Std) Buna-N (Opt)

Lubrication: Requires 66 oz. of Udor Lube 40W Premium Pump Oil.
Alternate Oil: 30W non-detergent or 15W-40 non-detergent oil.

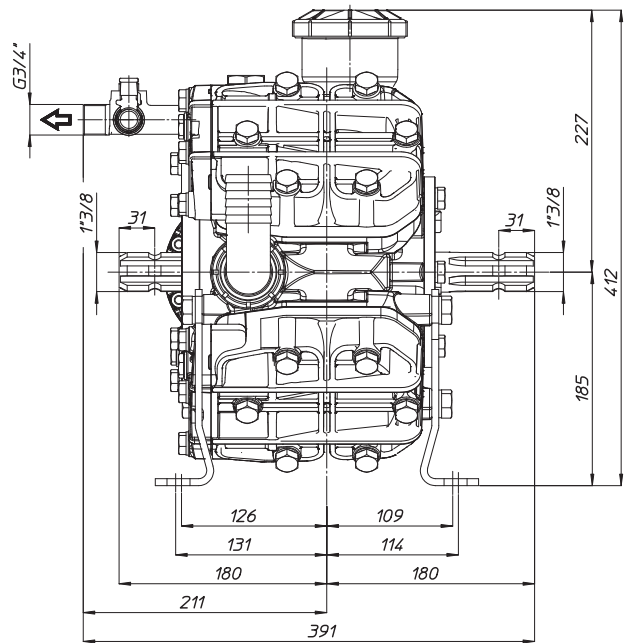
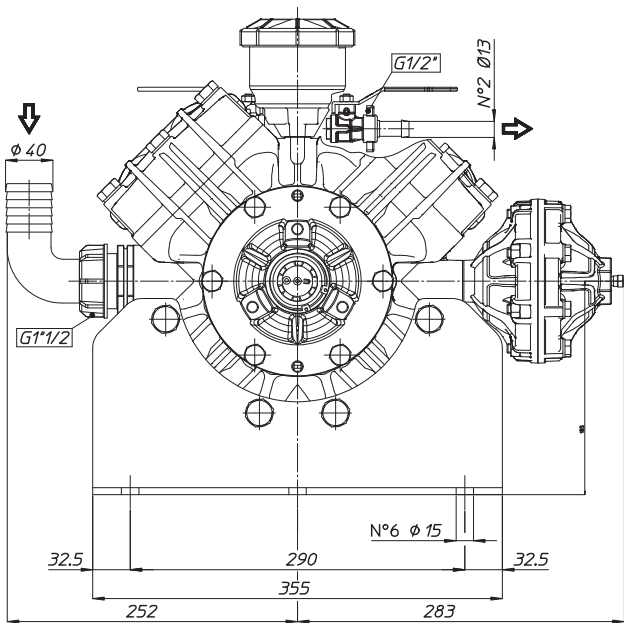

TORQUE SPECS

Ref.	Description	Ft./lb.	Nm
1	Diaphragm Bolts (Use Loctite 243)	23	30
2	Head Bolts	37	90
3	Pulsation Dampener Bolts	18	25
4	Inlet Flange Bolts	36	50
5	Bearing Flange Bolts	36	50
6	Oil Cup Bolts	7	10
7	Valve Cover Bolts	36	50

