

OMEGA 135 / OMEGA 139



Scan this QR Code for more information



GREENTECH Diaphragms Standard. Buna-N Optional.

OMEGA 135 and OMEGA 139 3-cylinder, high pressure, high volume diaphragm pumps are constructed of anodized aluminum, brass and stainless steel and have anodized aluminum, brass and stainless steel liquid handling parts. Includes mounting rails and 6005.05 control unit with pressure gauge. Simplicity of design and common parts allow for easy and economical maintenance.

OMEGA 135 and OMEGA 139 pumps are excellent choices for various horticultural and agricultural spraying applications.



OMEGA 139 TS2C



OMEGA 135 TS2C

Model	GPM	l/min	PSI	bar	RPM	Drive Configuration	Weight
OMEGA 135 TS2C	39.0	140	580	40	550	1-3/8" 6-Spline Male PTO Thru-Shaft	62 LBS
OMEGA 139 TS2C	39.0	140	725	50	550	1-3/8" 6-Spline Male PTO Thru-Shaft	62 LBS

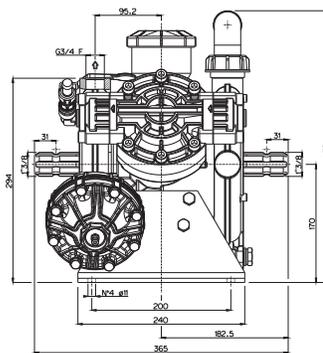
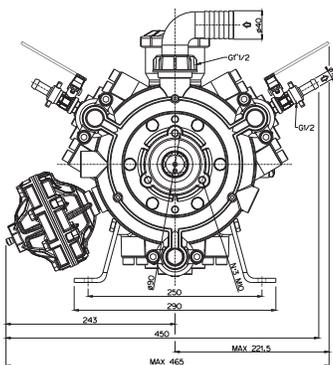

Dimensional Drawings are Shown in Millimeters. To Convert to Inches, Multiply Dimension x 0.03937

Specifications

OMEGA 139

Inlet Port	1-1/2" Hose Barb
Outlet Ports	(2) 1/2" Hose Barb Valve, 3/4" FPT
Bypass	1" Hose Barb
Piston Diameter	75mm
Crankshaft Stroke/Code	19.0mm / U
Dimensions	17.4"L x 15.5"W x 17.2"H

Lubrication: Requires 54 oz. of Udor Lube 40W Premium Pump Oil. Alternate Oil: 30W non-detergent or 15W-40 non-detergent oil.

QUICK REFERENCE SERVICE PARTS

Description	Part #
Diaphragm Kit (GREENTECH)	6062.H2
Diaphragm Bolt / Washer Kit	6062.16
Valve Kit	6062.D9
Complete Repair Kit (OMEGA 139 Only)	8700.30CK

Recommended Accessories and Drive Options



6066.09
Shaft Protector and Mounting Bolts



6066.05
PTO Drive Safety Shield



6005.05
Control Unit Regulator



0016.04
Venturi Agitator
1/2" MNPT Inlet



UD1-1/2-16
1-1/2" HI-Flow Filter
16 Mesh Screen



15.5823
Udor Lube Premium Pump Oil