

Scan this QR Code for more information



GREENTECH Diaphragms Standard. Buna-N Optional.

DELTA 75 3-cylinder, medium pressure diaphragm pumps are internally manifolded with anodized aluminum construction and anodized aluminum and stainless steel liquid handling parts.

DELTA 75 pumps are excellent choices for various horticultural, agricultural, lawn care, nursery, pest control and turf spraying applications. They are also effectively used for aircraft de-icing, hydrostatic testing and cleaning applications.

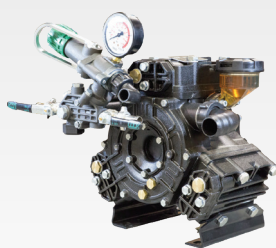

DELTA 75 VA

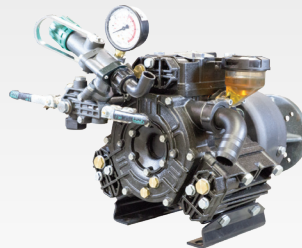

DELTA 75 VAGR1

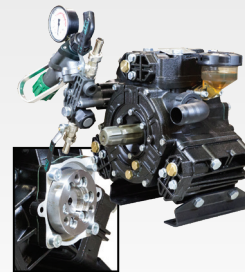

DELTA 75 TSWA

Model	GPM	l/min	PSI	bar	RPM	Drive Configuration	Weight
DELTA 75 VA	20.0	79.0	560	38	550	Universal VA Drive Face. Mounting Rails	46 LBS
DELTA 75 VAGR1	20.0	79.0	560	38	550	Gear Reduction for 1" Shaft Gas Engine, 8-20 HP	58 LBS
DELTA 75 TSWA	20.0	79.0	560	38	550	Universal VA Drive Face x 1-3/8" 6-Spline Male PTO	46 LBS

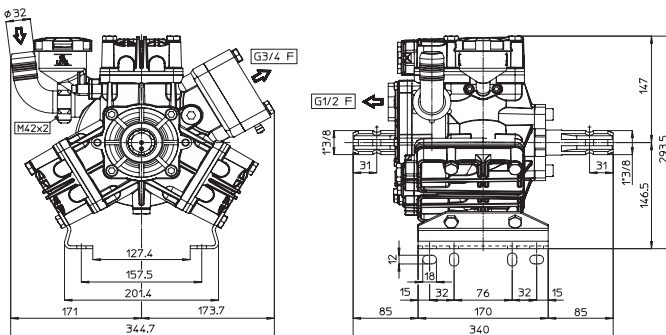

Dimensional Drawings are Shown in Millimeters. To Convert to Inches, Multiply Dimension x 0.03937

Specifications

DELTA 75

Inlet Port	1-1/4" Hose Barb
Outlet Ports	(2) 1/2" Hose Barb
Bypass	3/4" Hose Barb
Piston Diameter	60mm
Crankshaft Stroke/Code	170mm / G
Dimensions	13.5"L x 14.0"W x 12.0"H

Lubrication: Requires 40 oz. of Udor Lube 40W Premium Pump Oil. Alternate Oil: 30W non-detergent or 15W-40 non-detergent oil.

QUICK REFERENCE SERVICE PARTS

Description	Part #
Diaphragm Kit (GREENTECH)	6062.E4
Diaphragm Bolt / Washer Kit	6062.48
6Valve Kit	6062.E6
Regulator Repair Kit	6062.53
Complete Repair Kit	8700.75CK

Recommended Accessories and Drive Options

