

- Solid Ceramic Plungers
- Stainless Steel Check Valves
- Heavy Duty Brass Manifold
- Heavy Duty Bronze Connecting Rods
- Deeper Back Cover for Increased Oil Capacity
- 34.5 oz. Capacity Vented Oil Bath Crank Case
- 3/4" BSP-F Inlet. 3/8" BSP-F Outlet
- Max Fluid Temp, 160°F

### CXC Series 24mm Keyed Solid Shaft Plunger Pumps

CXC Series super duty plunger pumps include a wide range of models with flow rates from 4.0 to 5.8 GPM and pressures up to 7250 PSI.

Other drive options include gas engine gear reduction.

Applications include general pressure cleaning,, construction, hydro-excavation and oil field applications.

	Model	Flow		Pressure		Plunger Dia.	Crankshaft		Power	Seal Kit	Valve Kit	Wt.
		GPM	l/min	PSI	bar		Stroke	Code				
1450 RPM	CXC 15/50 S	4.0	15.0	7250	500	15mm	21.0mm	E	19.2 EBHP	6061.88	6061.S5	52 lbs
	CXC 18/50 S	4.8	18.0	7250	500	18mm	17.0mm	Y	23.1 EBHP	6061.G2	6061.S5	52 lbs
	CXC 22/50 S	5.8	22.0	7250	500	18mm	21.0mm	E	28.2 EBHP	6061.G2	6061.S5	52 lbs

NOTE: All pump models available with left-hand drive option. Add 'L' to model number when ordering (ex. CXC 22/50 SL)



MAX FLOW  
MAX PRESSURE  
RATED PUMP SPEED  
POWER REQUIREMENT  
LUBRICATION

5.8 GPM / 22.0 L/MIN  
7250 PSI / 500 BAR  
1450 RPM  
28.2 HP ELECTRIC  
34.5 OZ UDOR LUBE

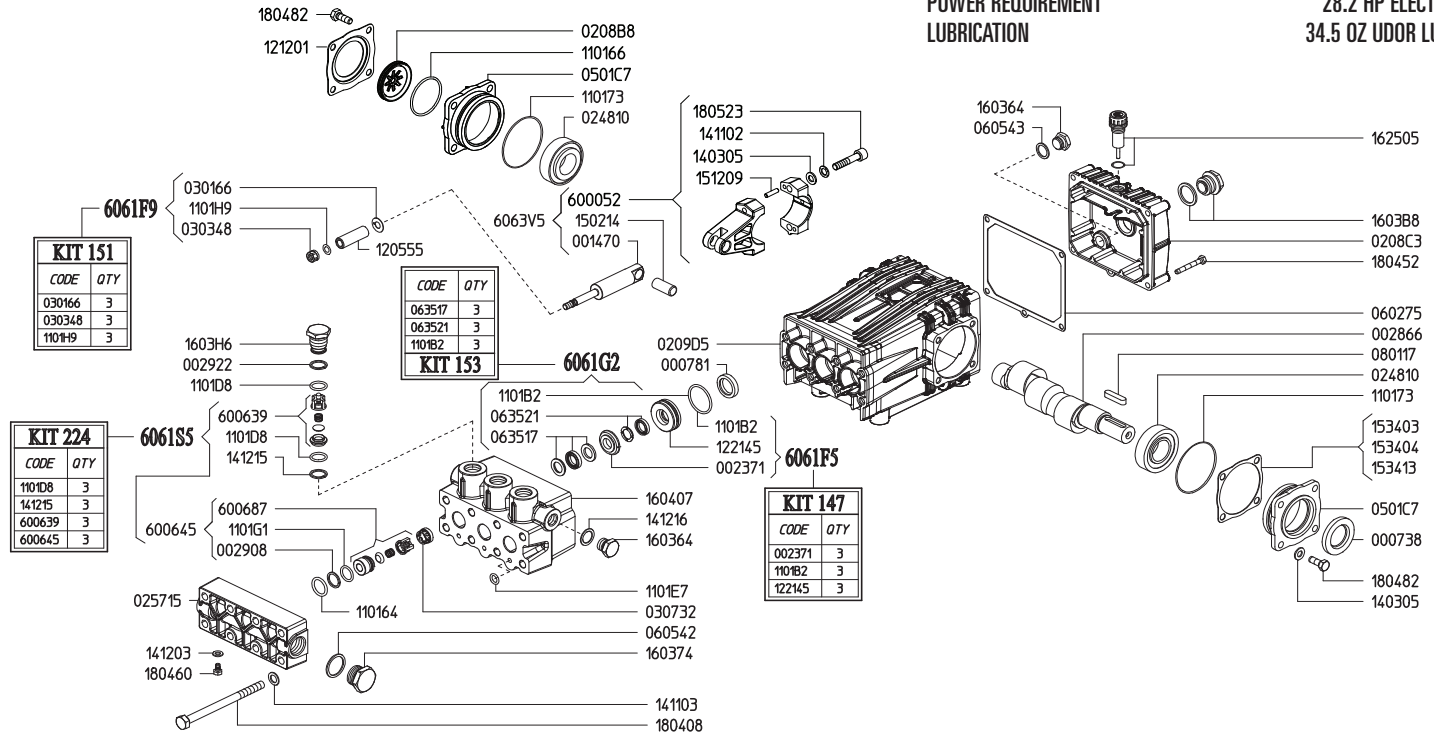

Revised 2-22-2022

Part #	Description	Qty	Part #	Description	Qty
0007.38	OIL SEAL D30	1	1403.05	WASHER D8.4	10
0007.81	OIL SEAL D20	3	1411.02	SERRATED WASHER D8	6
0014.69	PLUNGER GUIDE D15 "CX/CH"	3	1411.03	SERRATED WASHER D10	8
0023.71	UPPER RING D18 <sup>D</sup>	3	1412.03	SERRATED WASHER D10	1
0028.66	MALE SHAFT "CX" D24	1	1412.15	RING 400BAR <sup>A</sup>	3
0029.08	RING	3	1412.16	BONDED WASHER D17.3	1
0029.22	RING D15.2	3	1502.14	PIN D14X32	3
0208.B8	OIL SIGHT GLASS	1	1512.09	PLUG D5X20 UNI1707	6
0208.C3	BACK COVER "C/CK/CX"	1	1534.03	SHIM 0.1 MM	-
0209.D5	CRANKCASE "C/CK/CH/CX"	1	1534.04	SHIM 0.2 MM	-
0248.10	ROLLER BEARING D30	2	1534.13	SHIM 0.05 MM	-
0257.15	SUCTION MANIFOLD "CX"	1	1603.64	PLUG G3/8	2
0301.66	SLINGER RING <sup>B</sup>	3	1603.74	PLUG G3/4	1
0303.48	NUT D18 <sup>B</sup>	3	1603.B8	OIL PLUG G3/4 + GASKET	1
0307.32	SPACER D16/18	3	1603.H6	VALVE PLUG "CK/CX" PISTON D20	3
0501.C7	BEARING HOLLOW FLANGE	2	1604.07	HEAD "CX" PISTON D18	1
0602.75	BACK COVER GASKET	1	1625.05	OIL PLUG G3/8	1
0605.42	GASKET D27	1	1804.08	HEX BOLT M10X140	8
0605.43	GASKET D17	1	1804.09	HEX BOLT M8X40	6
0635.17	HIGH PRESS. SEAL KIT D18 <sup>C</sup>	3	1804.52	HEX BOLT M6X45	5
0635.21	LOW PRESS. SEAL KIT D18 <sup>C</sup>	3	1804.60	HEX BOLT M6X10	1
0801.17	KEY A8X7X35	1	1804.82	HEX BOLT M8X22	8
1101.64	O-RING - INLET VALVE	3	6000.41	ROD ASSEMBLY	3
1101.66	O-RING - OIL SIGHT GLASS	1	6006.39	VALVE ASSY 400BAR W/O O-RING <sup>A</sup>	3
1101.73	O-RING - BEARING FLANGE	2	6006.45	SUCTION VALVE ASSEMBLY COMPLETE <sup>A</sup>	3
1101.B2	O-RING - PRESSURE RING <sup>C,D</sup>	3	6006.87	SUCTION VALVE ASSEMBLY	3
1101.D8	O-RING - DISCHARGE VALVE <sup>A</sup>	3	6061.F9	PLUNGER KIT D18 (KIT 151)	
1101.D8	O-RING - DISCHARGE VALVE	3	6061.F5	BRASS RING KIT (KIT 147)	
1101.E7	O-RING - SPLIT MANIFOLD	3	6061.G2	WATER SEAL KIT (KIT 153)	
1101.G1	O-RING - INLET VALVE	3	6061.S5	VALVE KIT D15/18 "CX" (KIT 224)	
1101.H9	O-RING - PLUNGER BOLT 90SHORE <sup>B</sup>	3			
1205.55	CERAMIC PLUNGER D18	3			
1212.01	RETAINER - OIL SIGHT GLASS	1			
1221.45	PRESSURE RING D18 <sup>D</sup>	3			

<sup>A</sup> Parts in 6061.S5 (Kit 224).

<sup>B</sup> Parts in 6061.F9 (Kit 151).

<sup>C</sup> Parts in 6061.G2 (Kit 153).

<sup>D</sup> Parts in 6061.F5 (Kit 147).

*Dimensional Drawings are  
Shown in Millimeters.  
To Convert to Inches,  
Multiply Dimension x 0.03937*

## CX SERIES PUMPS - 24mm SOLID SHAFT

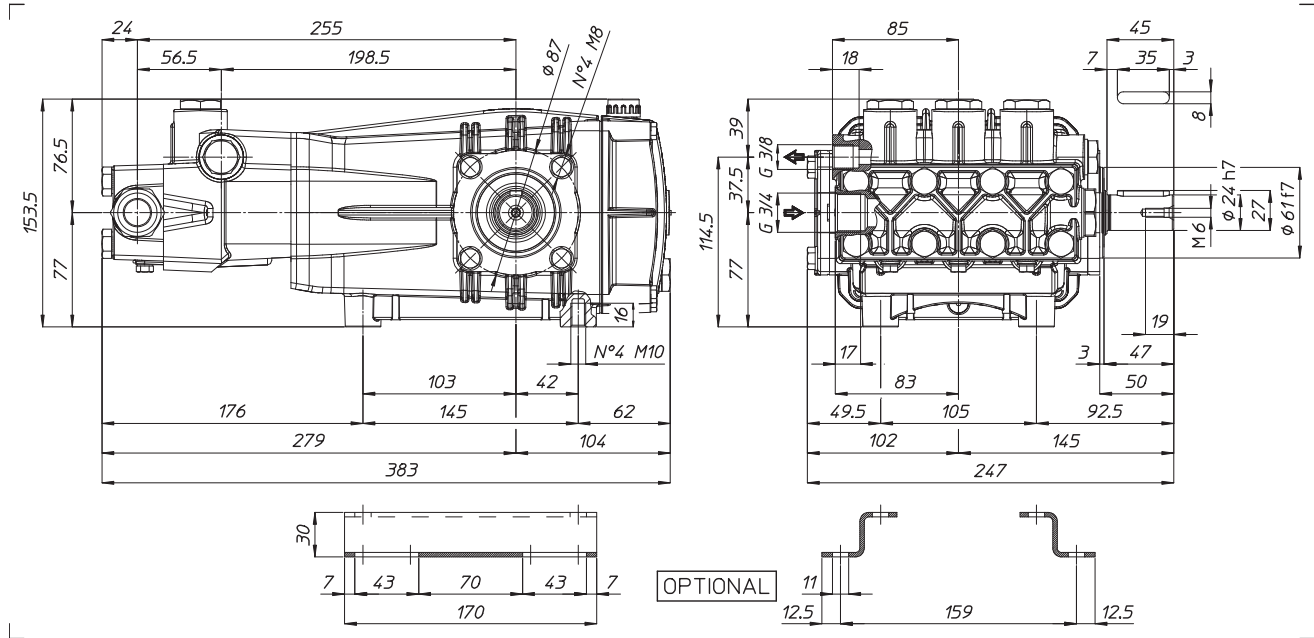

## TORQUE SPECS

Ref.	Description	Ft./lb.	Nm	Loctite®
1	Head Bolts	37	50	-
2	Valve Caps	-	-	-
3	Inlet Cap	103	140	-
4	Outlet Cap	60	80	243
5	Bearing Flange Bolts	19	25	-
6	Rear Cover Bolts	8	11	-
7	Connecting Rod Bolts	19	25	270
8	Plunger Bolts	15	20	270
9	Valve Cover Bolts	37	50	-
10	Oil Drain Plug	8	11	-

