

Gear Reduction, Gas Engine Models

1" or 1-1/8" Hollow Shaft, SAE J609-B Flange.
2.2:1 Gear Reduction Drive

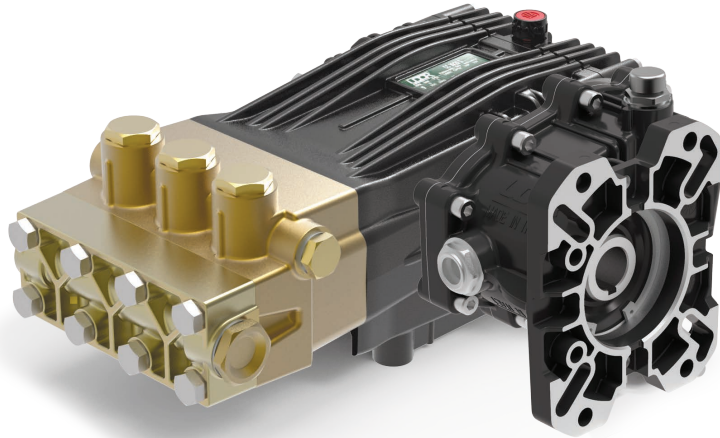

- Solid Ceramic Plungers
- Stainless Steel Check Valves
- Heavy Duty Brass Manifold
- Heavy Duty Bronze Connecting Rods
- Deeper Back Cover for Increased Oil Capacity
- 34.5 oz. Capacity Vented Oil Bath Crank Case
- 3/4" BSP-F Inlet. 3/8" BSP-F Outlet
- Max Fluid Temp, 160°F

CXC Series Gas Engine, Gear Reduction Drive Plunger Pumps

CXC Series super duty plunger pumps include a wide range of models with flow rates from 4.0 to 5.8 GPM and pressures up to 7250 PSI.

Other drive options include a 24mm solid, keyed shaft.

Applications include general pressure cleaning,, construction, hydro-excavation and oil field applications.

	Model	Flow		Pressure		Plunger Dia.	Crankshaft		Power	Seal Kit	Valve Kit	Wt.
		GPM	l/min	PSI	bar		Stroke	Code				
Gear Reduction	CXC 15/50 GR	4.0	15.0	7250	500	15mm	21.0mm	E	26.0 HP Gas	6061.88	6061.S5	59 lbs
	CXC 18/50 GR	4.8	18.0	7250	500	18mm	17.0mm	Y	32.0 HP Gas	6061.G2	6061.S5	59 lbs
	CXC 22/50 GR	5.8	22.0	7250	500	18mm	21.0mm	E	36.0 HP Gas	6061.G2	6061.S5	59 lbs

NOTE: All models available with 1" or 1-1/8" Hollow Shafts . Specify size when ordering (ex. **CXC 15/50 GR1** or **CXC 15/50 GR1-1/8.**)



MAX FLOW
MAX PRESSURE
RATED PUMP SPEED
POWER REQUIREMENT
LUBRICATION

5.8 GPM / 22.0 L/MIN
7250 PSI / 500 BAR
1450 RPM
36.5 HP GAS
34.5 OZ UDOR LUBE

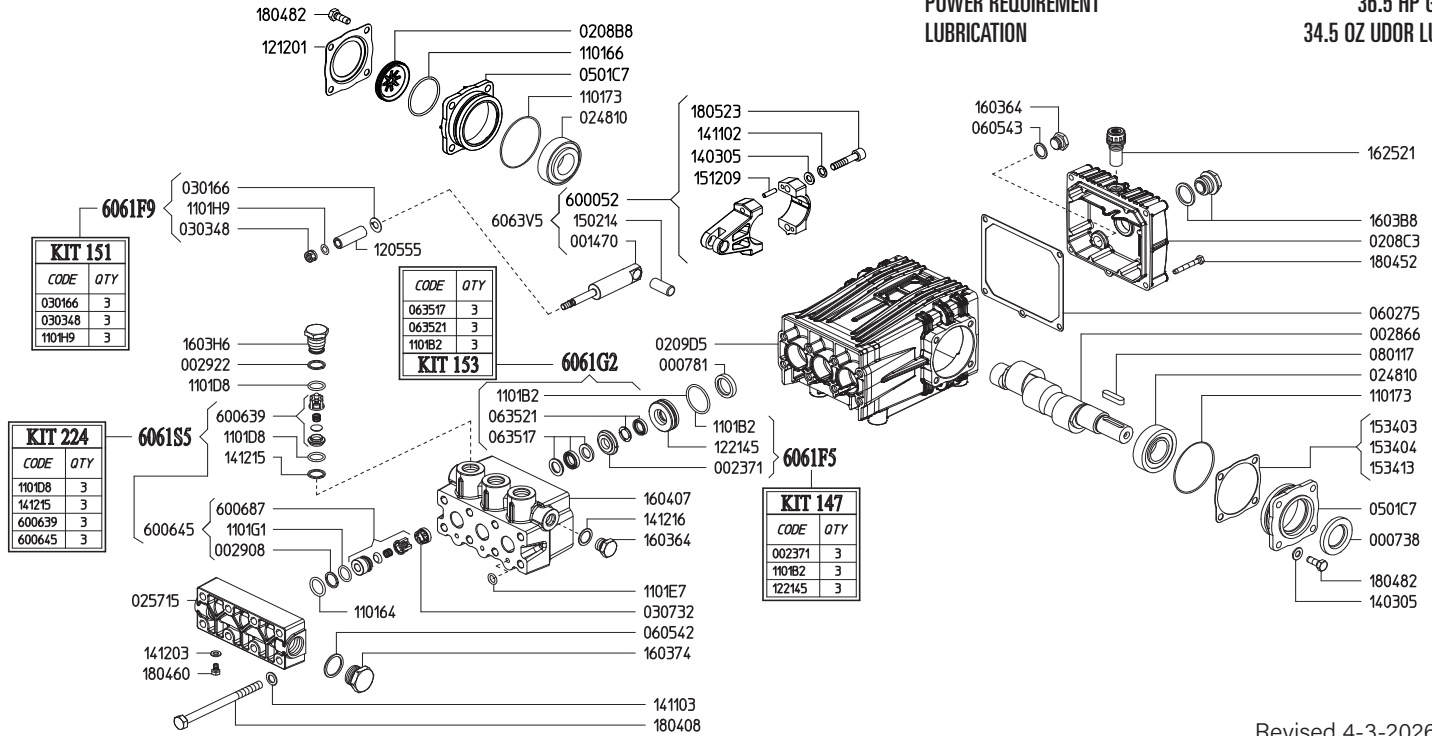

Revised 4-3-2026

Part #	Description	Qty
0007.38	OIL SEAL D30	1
0007.81	OIL SEAL D20	3
0014.69	PLUNGER GUIDE D15 "CX/CH"	3
0023.71	UPPER RING D18 ^D	3
0028.66	MALE SHAFT "CX" D24	1
0029.08	RING	3
0029.22	RING D15.2	3
0208.B8	OIL SIGHT GLASS	1
0208.C3	BACK COVER "C/CK/CX"	1
0209.D5	CRANKCASE "C/CK/CH/CX"	1
0248.10	ROLLER BEARING D30	2
0257.15	SUCTION MANIFOLD "CX"	1
0301.66	SLINGER RING ^B	3
0303.48	NUT D18 ^B	3
0307.32	SPACER D16/18	3
0501.C7	BEARING HOLLOW FLANGE	2
0602.75	BACK COVER GASKET	1
0605.42	GASKET D27	1
0605.43	GASKET D17	1
0635.17	HIGH PRESS. SEAL KIT D18 ^C	3
0635.21	LOW PRESS. SEAL KIT D18 ^C	3
0801.17	KEY A8X7X35	1
1101.64	O-RING - INLET VALVE	3
1101.66	O-RING - OIL SIGHT GLASS	1
1101.73	O-RING - BEARING FLANGE	2
1101.B2	O-RING - PRESSURE RING ^{C,D}	3
1101.D8	O-RING - DISCHARGE VALVE ^A	3
1101.D8	O-RING - DISCHARGE VALVE	3
1101.E7	O-RING - SPLIT MANIFOLD	3
1101.G1	O-RING - INLET VALVE	3
1101.H9	O-RING - PLUNGER BOLT 90SHORE ^B	3
1205.55	CERAMIC PLUNGER D18	3
1212.01	RETAINER - OIL SIGHT GLASS	1
1221.45	PRESSURE RING D18 ^D	3
1403.05	WASHER D8.4	10

Part #	Description	Qty
1411.02	SERRATED WASHER D8	6
1411.03	SERRATED WASHER D10	8
1412.03	SERRATED WASHER D10	1
1412.15	RING 400BAR ^A	3
1412.16	BONDED WASHER D17.3	1
1502.14	PIN D14X32	3
1512.09	PLUG D5X20 UNI1707	6
1534.03	SHIM 01 MM	-
1534.04	SHIM 0.2 MM	-
1534.13	SHIM 0.05 MM	-
1603.64	PLUG G3/8	2
1603.74	PLUG G3/4	1
1603.B8	OIL PLUG G3/4 + GASKET	1
1603.H6	VALVE PLUG "CK/CX" PISTON D20	3
1604.07	HEAD "CX" PISTON D18	1
1625.21	OIL PLUG G3/8	1
1804.08	HEX BOLT M10X140	8
1804.09	HEX BOLT M8X40	6
1804.52	HEX BOLT M6X45	5
1804.60	HEX BOLT M6X10	1
1804.82	HEX BOLT M8X22	8
6000.41	ROD ASSEMBLY	3
6006.39	VALVE ASSY 400BAR W/O O-RING ^A	3
6006.45	SUCTION VALVE ASSEMBLY COMPLETE ^A	3
6006.87	SUCTION VALVE ASSEMBLY	3
6063.V5	COMPLETE ROD ASSEMBLY	3
6061.F9	PLUNGER KIT D18 (KIT 151)	1
6061.F5	BRASS RING KIT (KIT 147)	1
6061.G2	WATER SEAL KIT (KIT 153)	1
6061.S5	VALVE KIT D15/18 "CX" (KIT 224)	1

^A Parts in 6061.S5 (Kit 224).

^B Parts in 6061.F9 (Kit 151).

^C Parts in 6061.G2 (Kit 153).

^D Parts in 6061.F5 (Kit 147).

**GAS ENGINE GEAR REDUCTION FOR
B/BK/BS/BWT/C/CS/CWT/CK/CX-SERIES PLUNGER PUMPS
on GAS ENGINES with 1" SHAFTS
REQUIRES 11.5 OZ. ISO VG 220 GEAR LUBE**

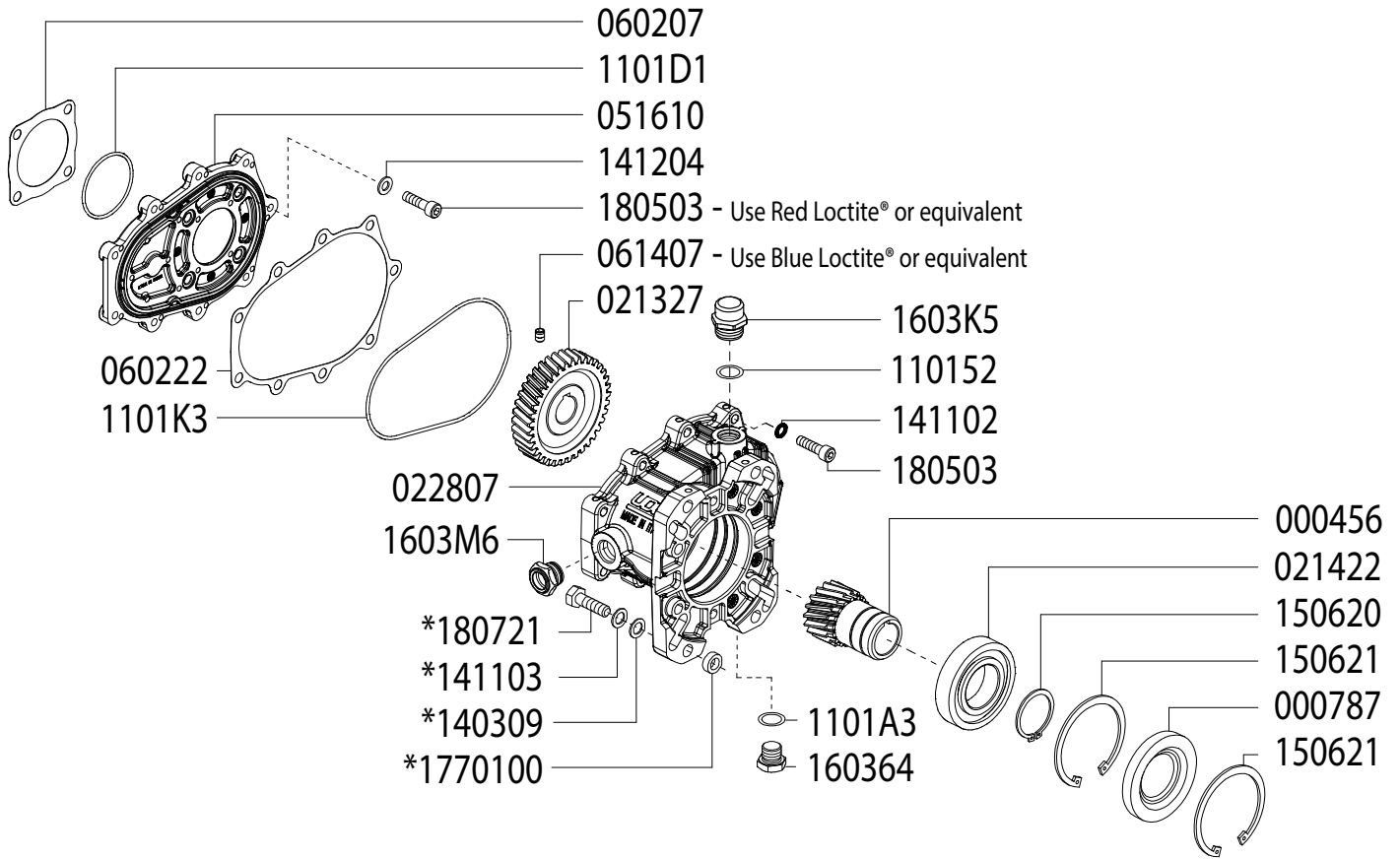

SEE NEXT PAGE FOR ASSEMBLY AND INSTALLATION INSTRUCTIONS

Updated 4-3-2026

Part #	Description	Qty	Part #	Description	Qty
0004.56	GEAR - 1"	1	*1403.09	WASHER	4
0007.87	OIL SEAL - D40 - RBC122K	1	1411.02	WASHER	9
0213.27	PUMP GEAR	1	*1411.03	SERRATED WASHER	4
0214.22	BEARING - D40 - RBC122K	1	1412.04	WASHER	4
0228.07	COUPLER - RBC122	1	1506.20	SNAP RING - D40	1
0516.10	FLANGE - RBC122	1	1506.21	SNAP RING - D80	2
0602.07	GASKET - RC122	1	1603.64	PLUG - 3/8"	1
0602.22	GASKET - RBC122 HOUSING	1	1603.K5	OIL PLUG - G3/8"	1
0614.07	SET SCREW - M5X8	1	1603.M6	OIL SIGHT GLASS	1
1101.52	O-RING - OIL PLUG	1	1805.03	ALLEN BOLT - M8x30	13
1101.A3	O-RING	1	*1807.21	HEX BOLT - 3/8-16 X 1-1/4"	4
1101.D1	O-RING	1	*1770.100	SPACER	4
1101.K3	O-RING	1			

* For use when using outer mounting holes only

**GAS ENGINE GEAR REDUCTION FOR
B/BK/BS/BWT/C/CS/CWT/CK/CX-SERIES PLUNGER PUMPS
on GAS ENGINES with 1-1/8" SHAFTS
REQUIRES 11.5 OZ. ISO VG 220 GEAR LUBE**

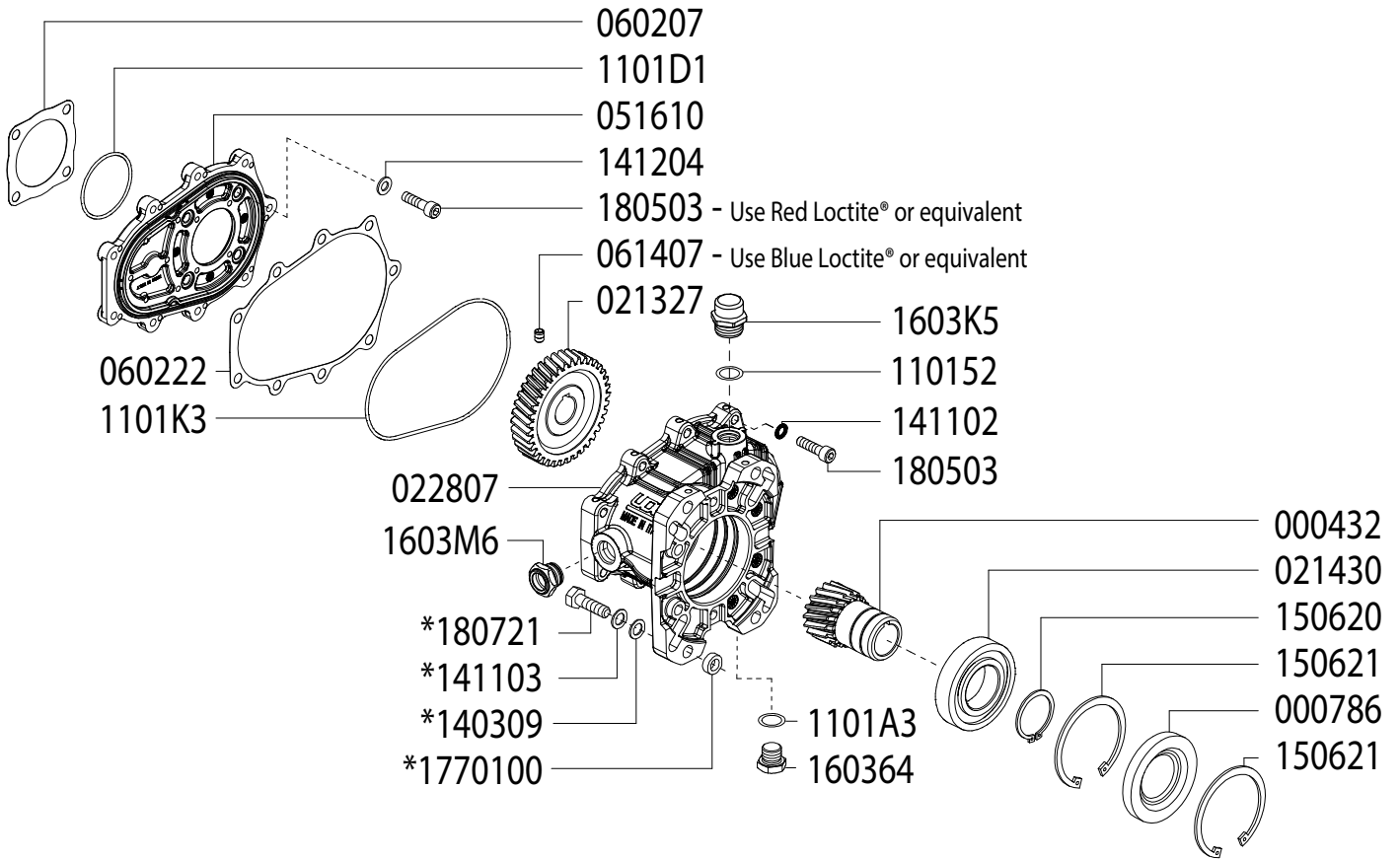

SEE NEXT PAGE FOR ASSEMBLY AND INSTALLATION INSTRUCTIONS

Updated 4-3-2026

Part #	Description	Qty	Part #	Description	Qty
0004.32	GEAR - 1-1/8"	1	*1403.09	WASHER	4
0007.86	OIL SEAL - D40 - RBC122X	1	1411.02	WASHER	9
0213.27	PUMP GEAR	1	*1411.03	SERRATED WASHER	4
0214.30	BEARING - D40 - RBC122X	1	1412.04	WASHER	4
0228.07	COUPLER - RBC122	1	1506.20	SNAP RING - D40	1
0516.10	FLANGE - RBC122	1	1506.21	SNAP RING - D80	2
0602.07	GASKET - RC122	1	1603.64	PLUG - 3/8"	1
0602.22	GASKET - RBC122 HOUSING	1	1603.K5	OIL PLUG - G3/8"	1
0614.07	SET SCREW - M5X8	1	1603.M6	OIL SIGHT GLASS	1
1101.52	O-RING - OIL PLUG	1	1805.03	ALLEN BOLT - M8x30	13
1101.A3	O-RING	1	*1807.21	HEX BOLT - 3/8-16 X 1-1/4"	4
1101.D1	O-RING	1	*17701.00	SPACER	4
1101.K3	O-RING	1			

* For use when using outer mounting holes only



RBC 122K / RBC 122X

8900.11/8900.08

**GAS ENGINE GEAR REDUCTION FOR
B/BK/BS/BWT/C/CS/CWT/CK/CX-SERIES PLUNGER PUMPS
on GAS ENGINES with 1" or 1-1/8" SHAFTS
REQUIRES 11.5 OZ. ISO VG 220 GEAR LUBE**

ASSEMBLY INSTRUCTIONS

- 1 With the pump shaft in vertical position, remove the 4 bolts that affix the bearing flange, leaving it in its position.
- 2 Place the gasket (p/n 060207) on the pump flange and the O-Ring 1101D1 between the pump and the flange (p/n 051610), then attach the flange (p/n 051610) using the Allen Bolts (p/n 180503) with relative bonded seal washers (p/n 141204). Make sure that the O-Ring (p/n 1101K3) is correctly contained in its seat and position the gasket (p/n 060222). Apply Red LOCTITE® (or equivalent) to the bolts (p/n 180503), and tighten with a torque of 19 lb-ft MAX.
- 3 After checking that the key is correctly seated, fit the helical pinion (p/n 021327) on the pump shaft pushing it against the shaft stop and locking it in position with the set screw (p/n 061407), tightening with a torque of 15 lb-ft max (use Blue LOCTITE® or equivalent).
- 4 Complete the assembly of the gearbox crankcase by screwing the oil sight glass (p/n 1603M6) and the plug (p/n 160364) with the corresponding O-Ring (p/n 1101A3).
- 5 Attach the gearbox crankcase assembly to the flange using the (9) Allen Bolts (p/n 180503) and washers (p/n 141102), tightening with a torque of 19 lb-ft MAX.
- 6 Fill the gearbox crankcase with oil (11.5 OZ. ISO VG 220 GEAR LUBE) until the level indicated in the center of the oil sight glass, then closing with the oil plug p/n 1603K5 and O-Ring (p/n 110152).

Note: If the pump-gearbox unit is not immediately coupled to the engine and have to be transported, to avoid possible oil leaks, temporarily use a plug G3/8 (not supplied) instead of the oil plug (p/n 1603K5).

ASSEMBLY OF THE PUMP-GEARBOX UNIT ON THE ENGINE:

- 1 Check that the key of the motor shaft is correctly seated, then apply a good anti-seize lubricant (such as LOCTITE® 8150) to the shaft to facilitate disassembly.
- 2 Then proceed to the coupling of the gearbox to the engine using the appropriate bolts and washers (supplied)
- 3 Tightening torques according to the bolts used.

3/8" - torque = 29 lb-ft MAX

5/16" - torque = 19 lb-ft MAX

WEIGHT
LUBRICATION

52 LBS
34.5 OZ UDOR LUBE

*Dimensional Drawings are
Shown in Millimeters.
To Convert to Inches,
Multiply Dimension x 0.03937*

CX SERIES PUMPS - 24mm SOLID SHAFT

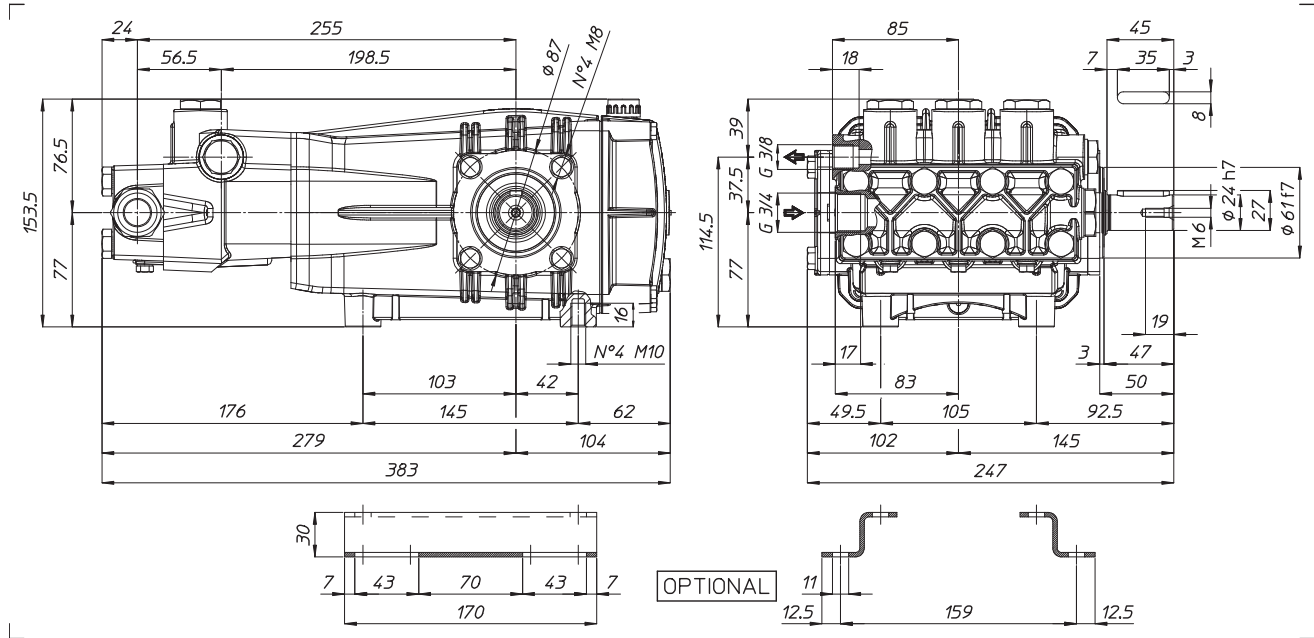

TORQUE SPECS

Ref.	Description	Ft./lb.	Nm	Loctite®
1	Head Bolts	37	50	-
2	Valve Caps	-	-	-
3	Inlet Cap	103	140	-
4	Outlet Cap	60	80	243
5	Bearing Flange Bolts	19	25	-
6	Rear Cover Bolts	8	11	-
7	Connecting Rod Bolts	19	25	270
8	Plunger Bolts	15	20	270
9	Valve Cover Bolts	37	50	-
10	Oil Drain Plug	8	11	-

