

High Temperature Solid Shaft Models

24mm Keyed Solid Shaft
1450 RPM

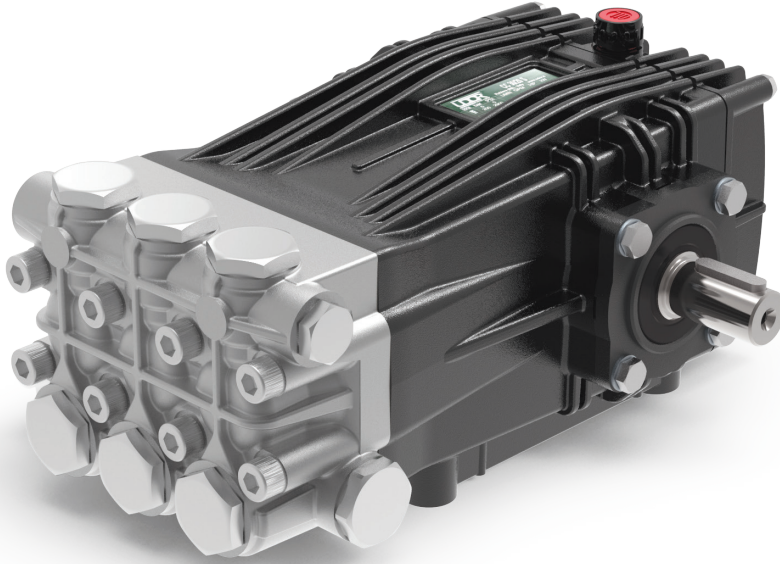

- Solid Ceramic Plungers
- Stainless Steel Check Valves
- Heavy Duty Plated Brass Manifold with External and Internal Bracing
- High Temperature Seals for Hot Water Applications
- Large Diameter Stainless Steel Valve Caps with Increased Thread Depth
- Reinforcing Ring on Inlet and Discharge Ports
- Deeper Back Cover for Increased Oil Capacity
- 35 oz. Capacity Vented Oil Bath Crank Case
- 3/4" BSP-F Inlet. 3/8" BSP-F Outlet: 5.5 - 8.5 GPM
- 3/4" BSP-F Inlet. 1/2" BSP-F Outlet: 9.0 GPM & Above
- Max Fluid Temp, 185°F

CWT Series 24mm Keyed Solid Shaft Plunger Pumps

CWT Series high temperature rated plunger pumps include a wide range of models with flow rates from 4.0 to 5.5 GPM and pressures up to 2900 PSI.

These pumps are designed and engineered with high temperature seals and nickel plated manifolds to withstand the demands of hot water applications

BWT series pumps are well suited for general pressure cleaning, disinfecting and food/pharma applications.

	Model	Flow		Pressure		Plunger Dia.	Crankshaft		Power	Seal Kit	Valve Kit	Wt.
		GPM	l/min	PSI	bar		Stroke	Code				
1450 RPM	CWTC 27/20 S	7.1	27.0	2900	200	22mm	17.0mm	X	13.8 EBHP	6061.N9	6061.03	35 lbs
	CWTC 30/20 S	7.9	30.0	2900	200	25mm	15.0mm	V	15.4 EBHP	6061.N9	6061.03	35 lbs
	CWTC 34/20 S	9.0	34.0	2900	200	25mm	17.0mm	X	17.4 EBHP	6061.N9	6061.03	35 lbs
	CWTC 42/17 S	11.6	44.0	2465	170	28mm	17.0mm	X	19.2 EBHP	6061.P2	6061.03	35 lbs
	CWTC 50/15 S	13.2	50.0	2175	150	28mm	19.0mm	Y	19.2 EBHP	6061.P2	6061.03	39 lbs
	CWTC 70/15 S	18.5	70.0	2175	150	30mm	24.0mm	2	36.9 EBHP	6061.P2	6072.26	39 lbs

NOTE: All pump models available with left-hand drive option. Add 'L' to model number when ordering (ex. CWTC 42/17 SL)



MAX FLOW 18.5 GPM / 70.0 L/MIN
MAX PRESSURE 2175 PSI / 150 BAR
RATED PUMP SPEED 1450 RPM
POWER REQUIREMENT 26.9 HP ELECTRIC
LUBRICATION 34.5 OZ UDOR LUBE

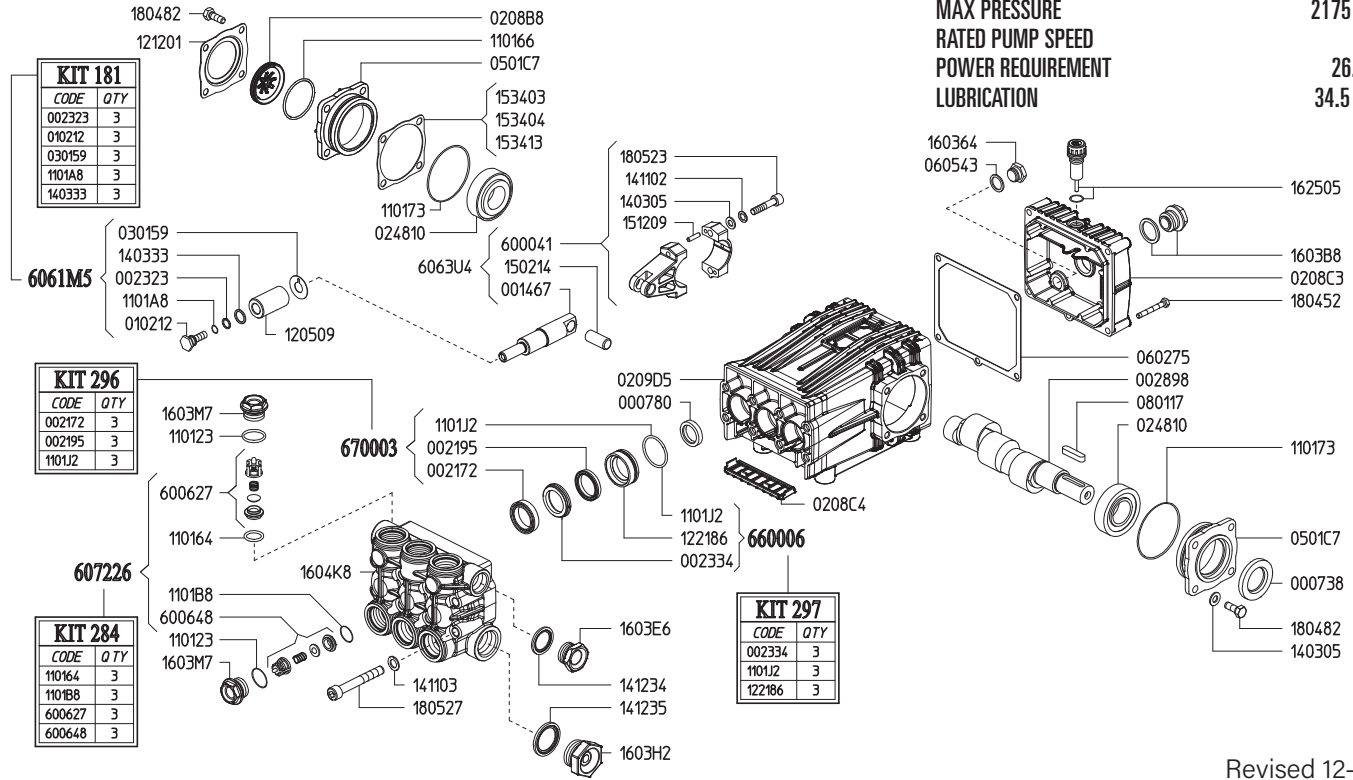

Revised 12-15-2023

Part #	Description	Qty
0007.38	OIL SEAL D30	1
0007.81	OIL SEAL D20	3
0014.67	PLUNGER GUIDE D22/25/28 "C/CK"	3
0021.72	WATER SEAL H.P. D30 ^C	3
0021.95	WATER SEAL L.P. D30 ^C	3
0023.23	RING D10.4 ^A	3
0023.34	UPPER RING ^B	3
0028.98	CRANKSHAFT D24	1
0102.12	PLUNGER BOLT ^A	3
0208.B8	OIL SIGHT GLASS	1
0208.C3	BACK COVER "C/CK"	1
0208.C4	COVER "C/CK"	1
0209.D5	CRANKCASE "C/CK/CH"	1
0248.10	ROLLER BEARING D30	2
0301.59	SLINGER RING D22 ^A	3
0501.C7	BEARING HOLLOW FLANGE	2
0602.75	BACK COVER GASKET	1
0605.43	GASKET D17	1
0801.17	KEY A8X7X35	1
1001.38	NIPPLE G3/4 M - 1" M	1
1101.23	O-RING - VALVE CAP	6
1101.64	O-RING - VALVE, DISCHARGE ^D	3
1101.66	O-RING - OIL SIGHT GLASS	1
1101.73	O-RING - BEARING FLANGE	2
1101.A8	O-RING - PLUNGER BOLT ^A	3
1101.B8	O-RING - VALVE, INLET ^D	3
1101.J2	O-RING - PRESSURE RING ^{B,C}	3
1205.09	CERAMIC PLUNGER	3
1212.01	RETAINER - OIL SIGHT GLASS	1
1221.86	PRESSURE RING ^B	3
1403.05	WASHER D8.4	10
1403.33	WASHER D13.2 ^A	3

Part #	Description	Qty
1411.02	SERRATED WASHER D8	6
1411.03	SERRATED WAHSER D10	8
1412.34	GASKET	1
1412.35	GASKET	1
1502.14	PIN D14X32	3
1512.09	PLUG D5X20	6
1534.03	SHIM 0.1 MM	1
1534.04	SHIM 0.2 MM	1
1534.13	SHIM 0.05 MM	1
1603.64	PLUG - 1/2"	1
1603.B8	OIL PLUG G3/4" + GASKET	1
1603.E6	PLUG G3/4	1
1603.H2	PLUG G1	2
1603.M7	VALVE CAP	6
1604.K8	HEAD	1
1625.05	OIL PLUG G3/8	1
1804.52	HEX BOLT M6X45	5
1804.82	HEX BOLT M8X22	8
1805.23	ALLEN BOLT M8X40	6
1805.27	ALLEN BOLT	8
6000.41	ROD ASSEMBLY	3
6006.27	VALVE - DISCHARGE ^D	3
6006.48	VALVE - INLET ^D	3
6061.M5	PLUNGER KIT (KIT 181)	1
6072.26	VALVE KIT (KIT 284)	1
6600.06	BRASS RING KIT (KIT 297)	1
6700.03	WATER SEAL KIT (KIT 296)	1

^A Parts in 6061.M5 (Kit 181).
^B Parts in 6600.06 (Kit 297).
^C Parts in 6700.03 (Kit 296).
^D Parts in 6072.26 (Kit 284).

WEIGHT
LUBRICATION

36 LBS
34.5 OZ UDOR LUBE

*Dimensional Drawings are
Shown in Millimeters.
To Convert to Inches,
Multiply Dimension x 0.03937*

CC 70/15 S & CD 18.5/22 S

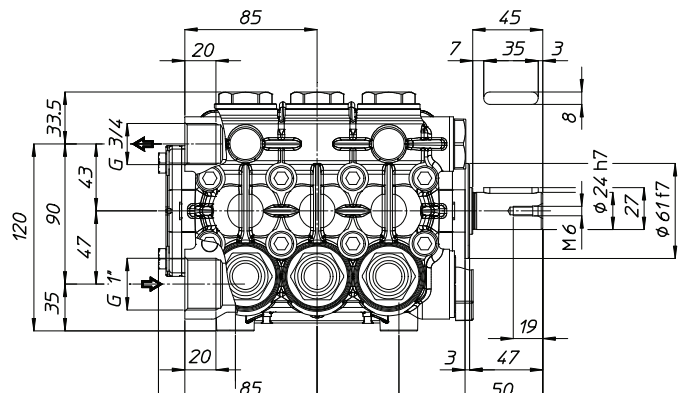
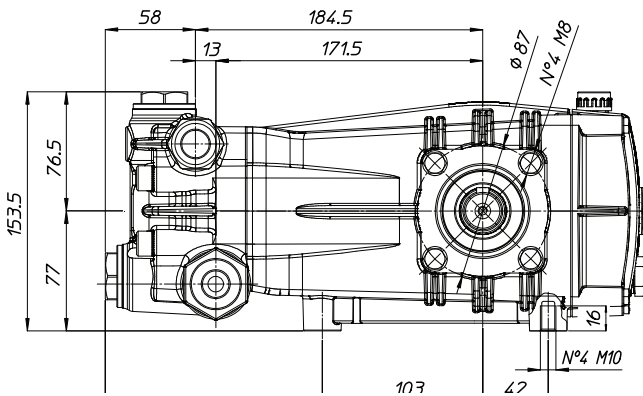

TORQUE SPECS

Ref.	Description	Ft./lb.	Nm	Loctite®
1	Head Bolts	37	50	-
2	Valve Caps	103	140	243
3	Inlet Cap	103	140	-
4	Outlet Cap	103	140	243
5	Bearing Flange Bolts	19	25	-
6	Rear Cover Bolts	8	11	-
7	Connecting Rod Bolts	19	25	270
8	Plunger Bolts	15	20	270
9	Valve Cover Bolts	-	-	-
10	Oil Drain Plug	8	11	-

