

- 316 Stainless Steel Manifolds
- 316 Stainless Steel Valves
- 316 Stainless Steel Plunger Rods & Nuts
- 304 Stainless Steel Exterior Bolts
- Solid Ceramic Plungers
- PTFE Style Packings
- 34.5 oz. Capacity Vented Oil Bath Crank Case
- 3/4" BSP-F Inlet. 1/2" BSP-F Outlet - Below 10 GPM
- 1" BSP-F Inlet. 1/2" BSP-F Outlet - Over 10 GPM
- Max Fluid Temp, 160°F

### CSC Series 24mm Keyed Solid Shaft Plunger Pumps

CSC Series stainless steel plunger pumps include a wide range of models with flow rates from 7.1 to 13.2 GPM and pressures up to 2900 PSI.

These pumps feature stainless steel wetted and exterior components to withstand the harsh environment of salt water applications.

CSC Series pumps are well suited for de-salination, disinfecting and food/pharma applications.

	Model	Flow		Pressure		Plunger Dia.	Crankshaft		Power	Seal Kit	Valve Kit	Wt.
		GPM	l/min	PSI	bar		Stroke	Code				
1450 RPM	CSC 27/20 S	7.1	27.0	2900	200	28mm	11.0mm	P	13.8 EBHP	6061.C2	6061.B9	43 lbs
	CSC 34/20 S	9.0	34.0	2900	200	28mm	13.5mm	N	17.4 EBHP	6061.C2	6061.B9	43 lbs
	CSC 42/17 S	11.6	44.0	2465	170	28mm	17.0mm	X	19.5 EBHP	6061.C2	6061.B9	44 lbs
	CSC 50/15 S	13.2	50.0	2175	150	28mm	19.0mm	Y	19.5 EBHP	6061.C2	6061.B9	44 lbs

All Models available with Gas Engine Gear Reductions. Contact UDOR USA for pricing and availability.



MAX OUTPUT  
MAX OUTPUT  
RATED PUMP SPEED  
POWER REQUIREMENT  
LUBRICATION

7.1 GPM / 27 L/MIN  
3000 PSI / 200 BAR  
1450 RPM  
14.0 HP ELECTRIC  
34.5 OZ UDOR LUBE

KIT 119	
CODE	QTY
002323	3
010218	3
030165	3
1101A8	3
141406	3

KIT 118	
CODE	QTY
002144	3
063529	3
1101A9	3

KIT 116	
CODE	QTY
110164	6
600654	6

KIT 117	
CODE	QTY
002362	3
1101A9	3
122137	3

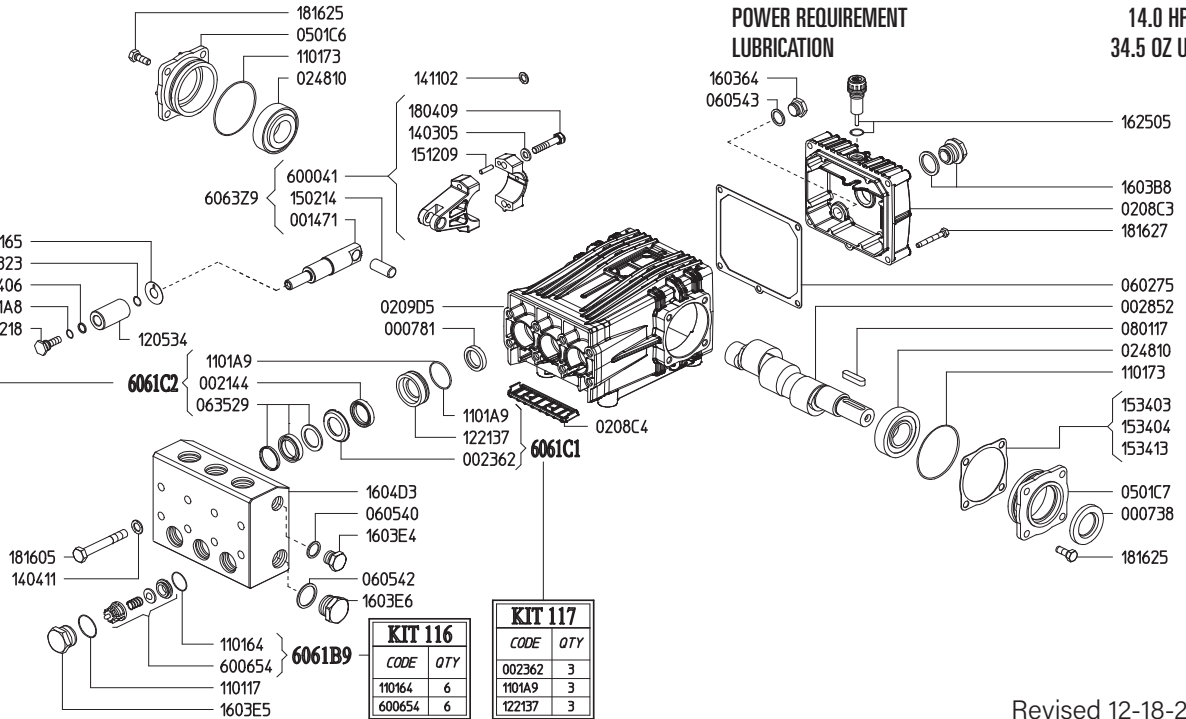

Revised 12-18-2023

Part #	Description	Qty	Part #	Description	Qty
0007.38	OIL SEAL D30	1	1404.11	GROWER WASHER D10.5 SS	8
0007.81	OIL SEAL D20	3	1411.02	SERATED WASHER D8	6
0014.71	PLUNGER GUIDE D28 "CS"	3	1414.06	WASHER D13.4 SS <sup>D</sup>	3
0021.44	WATER SEAL L.P. D28 BPE <sup>C</sup>	3	1502.14	PIN D14X32	3
0023.23	RING D10.4 <sup>D</sup>	3	1512.09	PLUG D5X20 UNI1707	6
0023.62	UPPER RING D28 "CS" SS <sup>B</sup>	3	1534.03	SHIM 0.1 MM	-
0028.52	MALE SHAFT D24	1	1534.04	SHIM 0.2 MM	-
0102.18	PLUNGER BOLT SS <sup>D</sup>	3	1534.13	SHIM 0.05 MM	-
0208.C3	BACK COVER "C/CK"	1	1603.64	PLUG G3/8	1
0208.C4	COVER "C/CK"	1	1603.B8	OIL PLUG G3/4 + GASKET	1
0209.D5	CRANKCASE "C/CK/CH/CS"	1	1603.E4	PLUG G1/2 SS	1
0248.10	ROLLER BEARING D30	2	1603.E5	VALVE PLUG "CS" PISTON D28 SS	6
0301.65	DISC "CS" SS <sup>D</sup>	3	1603.E6	PLUG G3/4 SS	1
0501.C6	BEARING CLOSED FLANGE	1	1604.D3	HEAD "CS" PISTON D28 SS	1
0501.C7	BEARING HOLLOW FLANGE	1	1625.05	OIL PLUG G3/8	1
0602.75	BACK COVER GASKET	1	1804.09	HEX BOLT M8X40	6
0605.40	GASKET D21.5	1	1816.05	HEX BOLT M10X90 SS	8
0605.42	GASKET D27	1	1816.25	HEX BOLT M8X20 SS	8
0605.43	GASKET D17	1	1816.27	HEX BOLT M6X45 SS	5
0635.29	HIGH PRESS. SEAL KIT D28 <sup>C</sup>	3	6000.41	ROD ASSEMBLY	3
0801.17	KEY A8X7X35 UNI6604	1	6006.54	VALVE ASSY "CS" W/O O-RING <sup>A</sup>	6
1101.17	O-RING - VALVE CAP	6	6061.B9	VALVE KIT "CS" (KIT 116)	1
1101.64	O-RING - VALVE <sup>A</sup>	6	6061.C1	SS RING KIT D28 "CS" (KIT 117)	1
1101.73	O-RING - BEARING FLANGE	2	6061.C2	WATER SEAL KIT D28 (KIT 118)	1
1101.A8	O-RING - PLUNGER BOLT <sup>D</sup>	3	6061.C3	PLUNGER KIT D28 "CS" (KIT 119)	1
1101.A9	O-RING - WATER SEAL <sup>B,C</sup>	3			
1205.34	CERAMIC PLUNGER D28	3			
1221.37	PRESSURE RING D28 "CS" SS <sup>B</sup>	3			
1403.05	WASHER D8.4	6			

<sup>A</sup> Parts in 6061.B9 (Kit 116).  
<sup>B</sup> Parts in 6061.C1 (Kit 117).  
<sup>C</sup> Parts in 6061.C2 (Kit 118).  
<sup>D</sup> Parts in 6061.C3 (Kit 119).

*Dimensional Drawings are  
Shown in Millimeters.  
To Convert to Inches,  
Multiply Dimension x 0.03937*

## CS SERIES PUMPS BELOW 10 GPM

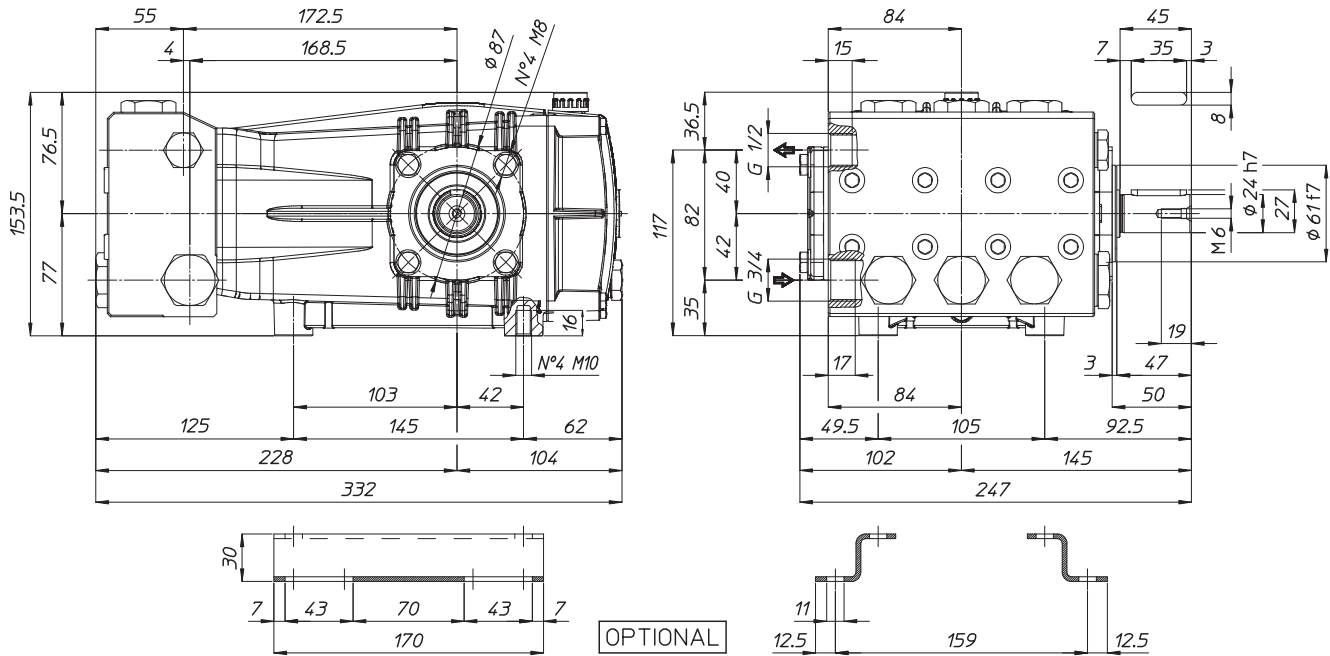

## TORQUE SPECS

Ref.	Description	Ft./lb.	Nm	Loctite®
1	Head Bolts	37	50	-
2	Valve Caps	103	140	243
3	Inlet Cap	103	140	-
4	Outlet Cap	103	140	243
5	Bearing Flange Bolts	19	25	-
6	Rear Cover Bolts	8	11	-
7	Connecting Rod Bolts	19	25	270
8	Plunger Bolts	15	20	270
9	Valve Cover Bolts	-	-	-
10	Oil Drain Plug	8	11	-

