

- Heavy Duty Brass Manifold with External and Internal Bracing
- Heavy Duty Bronze or Aluminum Connecting Rods
- Large Diameter Brass or Stainless Steel Valve Caps with Increased Thread Depth
- Reinforcing Ring on Inlet and Discharge Ports
- Stainless Steel Piston Guides and Check Valves
- Heat Treated Crank Shaft
- Industrial Quality Tapered Roller Bearings
- Deeper Back Cover for Increased Oil Capacity
- 34.5 oz. Capacity Vented Oil Bath Crank Case
- 3/4" BSP-F Inlet. 3/8" BSP-F Outlet - Less Than 10 GPM
- 3/4" BSP-F Inlet. 1/2" BSP-F Outlet - 10 GPM and Above
- Max Fluid Temp, 160°F

CKD Series 24mm Keyed Solid Shaft Plunger Pumps

CKD Series super duty plunger pumps include a wide range of models with flow rates from 4.5 to 13.2 GPM and pressures up to 5075 PSI.

Other drive options include gas engine gear reduction and hydraulic motor flange.

Applications include general pressure cleaning, sewer jetting, vehicle wash equipment, street cleaning, construction, hydro-excavation and UHP fire fighting applications.

	Model	Flow		Pressure		Plunger Dia.	Crankshaft		Power	Seal Kit	Valve Kit	Wt.
		GPM	l/min	PSI	bar		Stroke	Code				
1750 RPM	CKD 4.5/51 S	4.5	17.0	5075	360	20mm	11.0mm	P	15.3 EBHP	6061.D4	6061.63	39 lbs
	CKD 5.5/44 S	5.5	20.8	4350	300	22mm	11.0mm	P	16.0 EBHP	6061.10	6061.03	39 lbs
	CKD 5.5/50 S	5.5	20.8	5075	360	20mm	13.5mm	N	19.0 EBHP	6061.D4	6061.63	39 lbs
	CKD 6.0/51 S	6.0	22.7	5075	360	20mm	19.0mm	Y	20.4 EBHP	6061.D4	6061.63	39 lbs
	CKD 7.0/44 S	7.0	26.0	4350	300	22mm	13.5mm	N	22.0 EBHP	6061.10	6061.03	39 lbs
	CKD 7.0/50 S	7.0	26.0	5000	340	20mm	17.0mm	X	24.0 EBHP	6061.D4	6061.63	39 lbs
	CKD 7.5/44 S	7.5	28.4	4350	300	22mm	15.0mm	V	21.8 EBHP	6061.10	6061.03	39 lbs
	CKD 8.5/40 S	8.5	32.2	4060	280	22mm	17.0mm	X	23.5 EBHP	6061.10	6061.03	39 lbs
	CKD 9.5/36 S	9.5	36.0	3625	250	25mm	19.0mm	Y	23.0 EBHP	6061.11	6061.03	39 lbs
	CKD 11.0/32 S	11.0	41.5	3190	220	25mm	17.0mm	X	23.5 EBHP	6061.11	6061.03	39 lbs
CKD 12.0/30 S	12.0	45.5	2900	200	25mm	19.0mm	Y	23.4 EBHP	6061.11	6061.03	39 lbs	

NOTE: All pump models available with left-hand drive option. Add 'L' to model number when ordering (ex. CKD 70/44 SL)



MAX FLOW
MAX PRESSURE
RATED PUMP SPEED
POWER REQUIREMENT
LUBRICATION

7.0 GPM / 36.0 L/MIN
4350 PSI / 300 BAR
1750 RPM
22.0 HP ELECTRIC
34.5 OZ UDOR LUBE

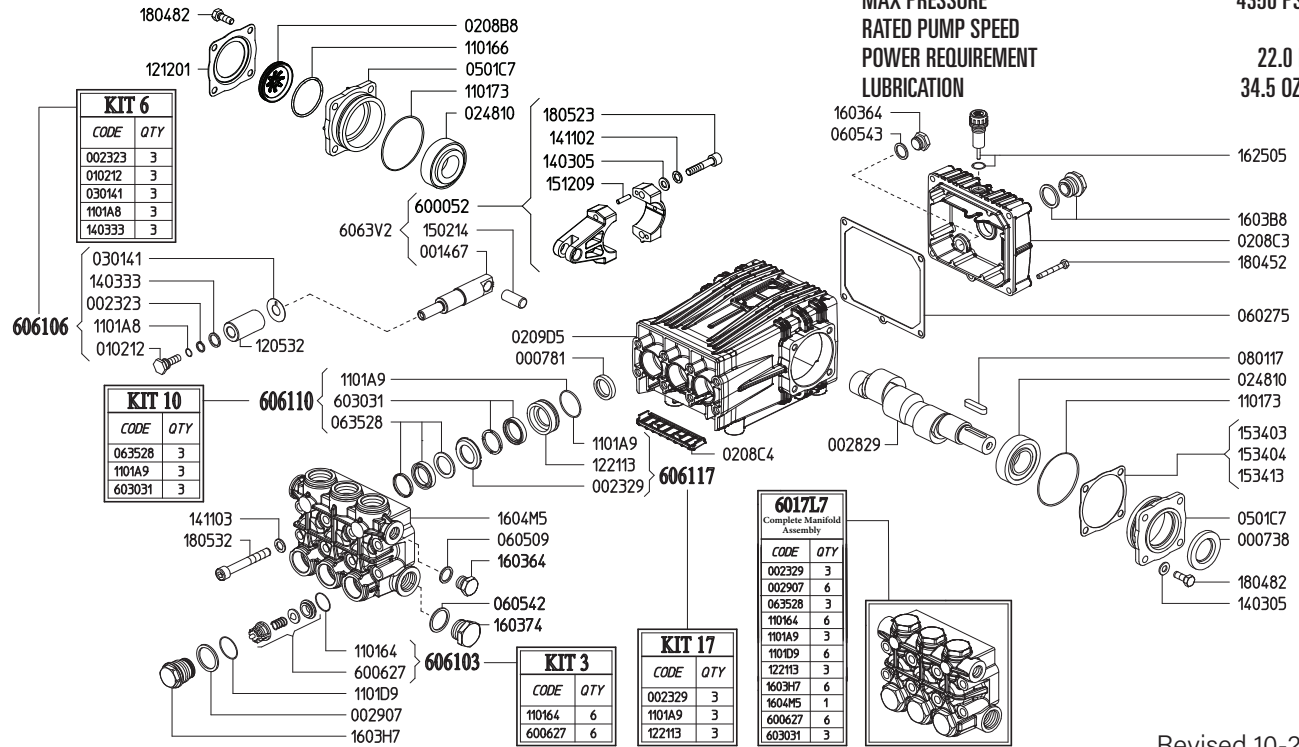

Revised 10-27-2023

Part #	Description	Qty
0007.38	OIL SEAL D30	1
0007.81	OIL SEAL D20	3
0014.67	PLUNGER GUIDE D22/25/28 "C/CK"	3
0023.23	RING D10.4 ^B	3
0023.29	UPPER RING D22 "CK" ^{D E}	3
0028.29	MALE SHAFT D24	1
0029.07	PLUG RING "CK" ^E	6
0102.12	PLUNGER BOLT ^B	3
0208.B8	OIL SIGHT GLASS	1
0208.C3	BACK COVER "C/CK"	1
0208.C4	COVER "CK"	1
0209.D5	CRANKCASE "C/CK/CH"	1
0248.10	ROLLER BEARING D30	2
0301.41	SLINGER RING ^B	3
0501.C7	BEARING HOLLOW FLANGE	2
0602.75	BACK COVER GASKET	1
0605.09	GASKET D17	1
0605.42	GASKET D27	1
0605.43	GASKET D17	1
0635.28	HIGH PRESS. SEAL KIT D22 ^{C E}	3
0801.17	KEY A8X7X35	1
1101.64	O-RING - VALVE ^{A E}	6
1101.66	O-RING - OIL SIGHT GLASS	1
1101.73	O-RING - BEARING FLANGE	2
1101.A8	O-RING - PLUNGER BOLT ^B	3
1101.A9	O-RING - PRESSURE RING ^{C D E}	3
1101.D9	O-RING - VALVE PLUG ^E	6
1205.32	CERAMIC PLUNGER D22	3
1212.01	RETAINER - OIL SIGHT GLASS	1
1221.13	PRESSURE RING D22 ^{D E}	3
1403.05	WASHER D8.4	10

Part #	Description	Qty
1403.33	WASHER D13.4 ^B	3
1411.02	SERATED WASHER D8	6
1411.03	SERATED WASHER D10	8
1502.14	PIN D14X32	3
1512.09	PLUG D5X20 UNI1707	6
1534.03	SHIM 0.1MM	-
1534.04	SHIM 0.2MM	-
1534.13	SHIM 0.05MM	-
1603.64	PLUG G3/8	2
1603.74	PLUG G3/4	1
1603.B8	OIL PLUG G3/4 + GASKET	1
1603.H7	VALVE PLUG "CK" PISTON D22/25 ^E	6
1604.M5	HEAD "CK" D22/25 ^E	1
1625.05	OIL PLUG G3/8	1
1804.52	HEX BOLT M6X45	5
1804.82	HEX BOLT M8X22	8
1805.23	ALLEN BOLT M8X40	6
1805.32	ALLEN BOLT M10X75	8
6000.52	ROD ASSEMBLY	3
6006.27	VALVE ASSEMBLY W/O O-RING ^{A E}	6
6017.L7	COMPLETE MANIFOLD ASSEMBLY	1
6030.31	LOW PRESSURE SEAL KIT D22 ^{C E}	3
6061.03	KIT 3 VALVE KIT	1
6061.06	KIT 6 PLUNGER KIT D22	1
6061.10	KIT 10 WATER SEAL KIT D22 "C/CK"	1
6061.17	KIT 17 BRASS RING KIT D22 "CK" 350BAR	1

^A Parts in 6061.03 (Kit 3).
^B Parts in 6061.06 (Kit 6).
^C Parts in 6061.10 (Kit 10).
^D Parts in 6061.17 (Kit 17).
^E Parts in 6017.L7 (Complete Manifold Assembly).

*Dimensional Drawings are
Shown in Millimeters.
To Convert to Inches,
Multiply Dimension x 0.03937*

CK SERIES PUMPS BELOW 10 GPM

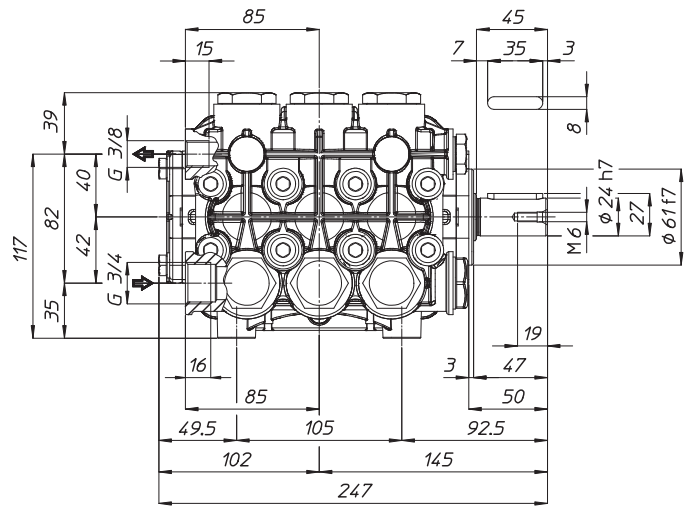

TORQUE SPECS

Ref.	Description	Ft./lb.	Nm	Loctite®
1	Head Bolts	37	50	-
2	Valve Caps	103	140	243
3	Inlet Cap	103	140	-
4	Outlet Cap	103	140	243
5	Bearing Flange Bolts	19	25	-
6	Rear Cover Bolts	8	11	-
7	Connecting Rod Bolts	19	25	270
8	Plunger Bolts	15	20	270
9	Valve Cover Bolts	-	-	-
10	Oil Drain Plug	8	11	-

