

Gear Reduction, Gas Engine Models

1" or 1-1/8" Hollow Shaft, SAE J609-B Flange.
2.2:1 Gear Reduction Drive

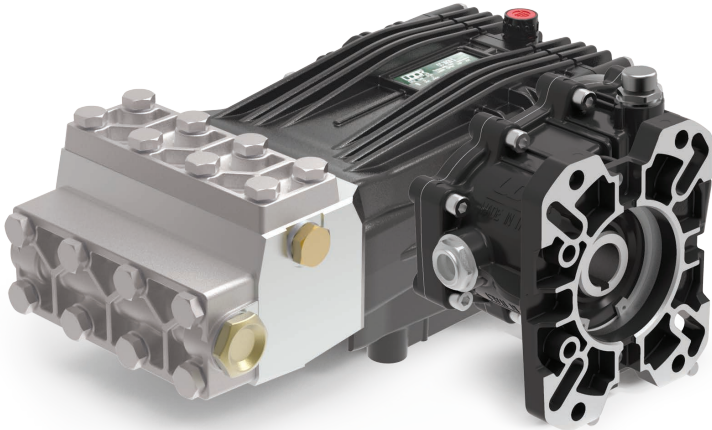

- Solid Ceramic Plungers
- Stainless Steel Check Valves
- Stainless Steel Block Manifold with Nickel Plated Valve Covers
- Deeper Back Cover for Increased Oil Capacity
- 34.5 oz. Capacity Vented Oil Bath Crank Case
- 3/4" BSP-F Inlet. 3/8" BSP-F Outlet
- Max Fluid Temp, 160°F

CHC Series Gas Engine, Gear Reduction Drive Plunger Pumps

CHC Series super duty plunger pumps include a wide range of models with flow rates from 3.2 to 5.3 GPM and pressures up to 7250 PSI.

Other drive options include a 24mm solid, keyed shaft.

Applications include general pressure cleaning,, construction, hydro-excavation and oil field applications.

	Model	Flow		Pressure		Plunger Dia.	Crankshaft		Power	Seal Kit	Valve Kit	Wt.
		GPM	l/min	PSI	bar		Stroke	Code				
Gear Reduction	CHC 12/50 GR	3.2	12.0	7250	500	15mm	17.0mm	X	20.0 HP Gas	6061.88	6061.G1	59 lbs
	CHC 16/50 GR	4.2	16.0	7250	500	15mm	22.0mm	1	26.0 HP Gas	6061.88	6061.G1	59 lbs
	CHC 20/50 GR	5.3	20.0	7250	500	18mm	19.0mm	Y	34.0 HP Gas	6061.G2	6061.G1	59 lbs

NOTE: All models available with 1" or 1-1/8" Hollow Shafts . Specify size when ordering (ex. **CHC 12/50 GR1** or **CHC 12/50 GR1-1/8.**)



CHC 20/50 GR

MAX FLOW
MAX PRESSURE
RATED PUMP SPEED
POWER REQUIREMENT
LUBRICATION

5.3 GPM / 20.0 L/MIN
7250 PSI / 500 BAR
1450 RPM
34.0 HP GAS
34.5 OZ UDOR LUBE

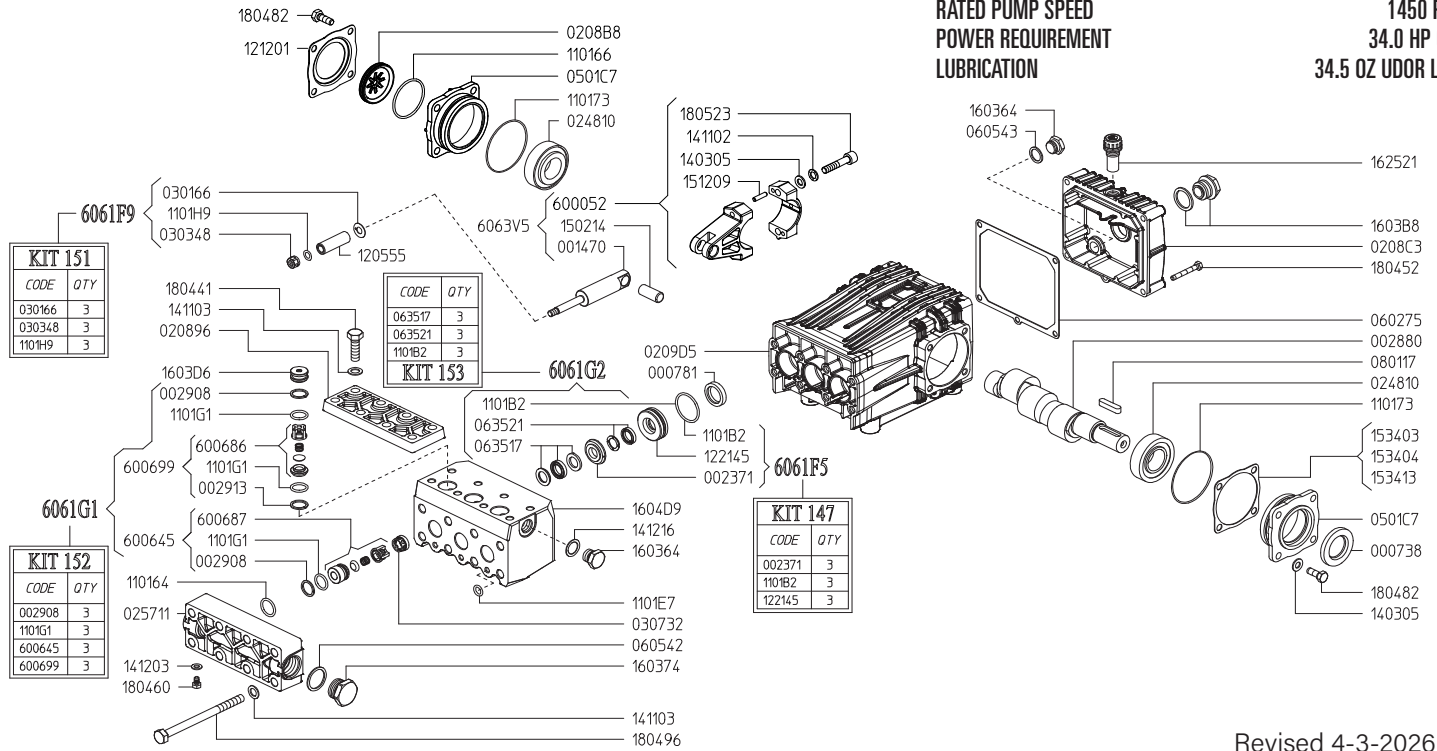

Revised 4-3-2026

Part #	Description	Qty	Part #	Description	Qty
0007.38	OIL SEAL D30	1	1403.05	WASHER D8.4	10
0007.81	OIL SEAL D20	3	1411.02	SERRATED WASHER D8	6
0014.69	PLUNGER GUIDE D15 "CH"	3	1411.03	SERRATED WASHER D10	16
0023.71	UPPER RING D18 ^D	3	1412.03	BONDED WASHER D6.7	1
0028.80	MALE SHAFT D24	1	1412.16	BONDED WASHER D17.3	1
0029.08	RING ^A	3	1502.14	PIN D14X32	3
0029.08	RING ^A / PART OF 6006.45	3	1512.09	PLUG D5X20 UNI1707	6
0029.13	RING ^A / PART OF 6006.99	3	1534.03	SHIM 0.1 MM	-
0208.96	COVER "CH"	1	1534.04	SHIM 0.2 MM	-
0208.B8	OIL SIGHT GLASS	1	1534.13	SHIM 0.05 MM	-
0208.C3	BACK COVER "C/CK"	1	1603.64	PLUG G3/8	2
0209.D5	GRANKCASE "C/CK/CH"	1	1603.74	PLUG G3/4	1
0248.10	ROLLER BEARING D30	2	1603.B8	OIL PLUG G3/4 + GASKET	1
0257.11	SUCTION MANIFOLD	1	1603.D6	PLUG	3
0301.66	SLINGER RING ^B	3	1604.D9	HEAD PISTON D18 SS	1
0303.48	NUT D18 ^B	3	1625.21	OIL PLUG G3/8	1
0307.27	SPACER	3	1804.09	HEX BOLT M8X40	6
0501.C7	BEARING HOLLOW FLANGE	2	1804.41	HEX BOLT M10X35	8
0602.75	BACK COVER GASKET	1	1804.52	HEX BOLT M6X45	5
0605.42	GASKET D27	1	1804.60	HEX BOLT M6X10	1
0605.43	GASKET D17	1	1804.82	HEX BOLT M8X22	8
0635.17	HIGH PRESSURE SEAL KIT D18 ^C	3	1804.96	HEX BOLT M10X140	8
0635.21	LOW PRESSURE SEAL KIT D18 ^C	3	6000.52	ROD ASSEMBLY	3
0801.17	KEY A8X7X35	1	6006.45	SUCTION VALVE ASS'Y COMPLETE ^A	3
1101.64	O-RING - SUCTION MANIFOLD	3	6006.86	OUTLET VALVE ASS'Y W/O O-RING ^A / in 6006.99	3
1101.66	O-RING - OIL SIGHT GLASS	1	6006.87	SUCTION VALVE ASS'Y W/O O-RING ^A / in 6006.45	3
1101.73	O-RING - BEARING FLANGE	2	6006.99	OUTLET VALVE ASS'Y COMPLETE ^A	3
1101.B2	O-RING - PRESSURE RING ^{C D}	3	6063.V5	COMPLETE ROD ASSEMBLY	3
1101.E7	O-RING - SPLIT MANIFOLD	3	6061.F5	BRASS RING KIT D18 (KIT 147)	1
1101.G1	O-RING - VALVE ^A	3	6061.F9	PLUNGER KIT D18 (KIT 151)	1
1101.G1	O-RING - VALVE ^A / in 6006.99	3	6061.G1	VALVE KIT D18 (KIT 152)	1
1101.G1	O-RING - VALVE ^A / in 6006.45	3	6061.G2	WATER SEAL KIT (KIT 153)	1
1101.H9	O-RING - PLUNGER ^B	3			
1205.55	CERAMIC PLUNGER D18	3			
1212.01	RETAINER - OIL SIGHT GLASS	1			
1221.45	PRESSURE RING D18 ^D	3			

^A Parts in 6061.G1 (Kit 152).

^B Parts in 6061.F9 (Kit 151).

^C Parts in 6061.G2 (Kit 153).

^D Parts in 6061.F5 (Kit 147).

**GAS ENGINE GEAR REDUCTION FOR
B/BK/BS/BWT/C/CS/CWT/CK/CX-SERIES PLUNGER PUMPS
on GAS ENGINES with 1" SHAFTS
REQUIRES 11.5 OZ. ISO VG 220 GEAR LUBE**

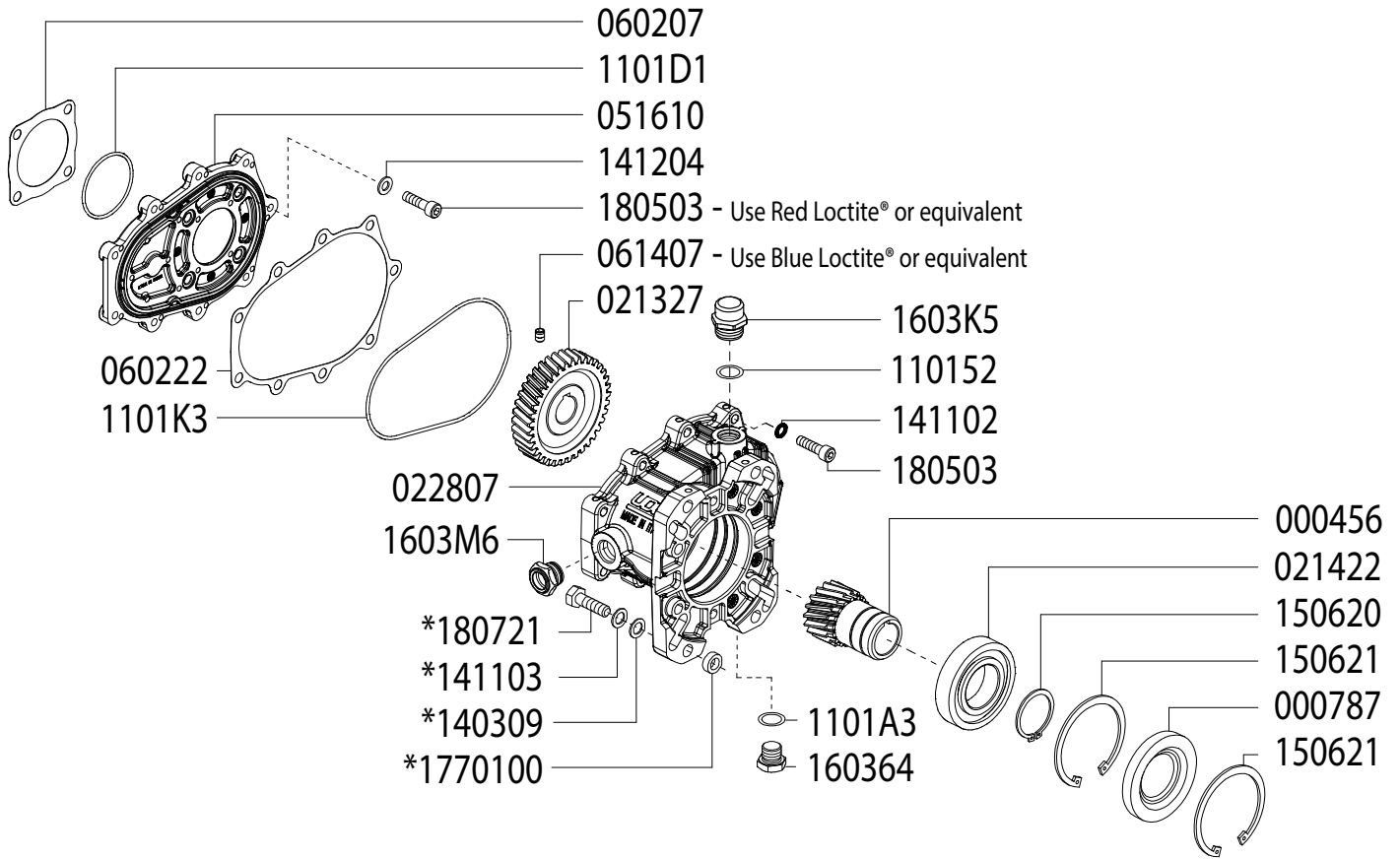

SEE NEXT PAGE FOR ASSEMBLY AND INSTALLATION INSTRUCTIONS

Updated 4-3-2026

Part #	Description	Qty	Part #	Description	Qty
0004.56	GEAR - 1"	1	*1403.09	WASHER	4
0007.87	OIL SEAL - D40 - RBC122K	1	1411.02	WASHER	9
0213.27	PUMP GEAR	1	*1411.03	SERRATED WASHER	4
0214.22	BEARING - D40 - RBC122K	1	1412.04	WASHER	4
0228.07	COUPLER - RBC122	1	1506.20	SNAP RING - D40	1
0516.10	FLANGE - RBC122	1	1506.21	SNAP RING - D80	2
0602.07	GASKET - RC122	1	1603.64	PLUG - 3/8"	1
0602.22	GASKET - RBC122 HOUSING	1	1603.K5	OIL PLUG - G3/8"	1
0614.07	SET SCREW - M5X8	1	1603.M6	OIL SIGHT GLASS	1
1101.52	O-RING - OIL PLUG	1	1805.03	ALLEN BOLT - M8x30	13
1101.A3	O-RING	1	*1807.21	HEX BOLT - 3/8-16 X 1-1/4"	4
1101.D1	O-RING	1	*1770.00	SPACER	4
1101.K3	O-RING	1			

* For use when using outer mounting holes only

**GAS ENGINE GEAR REDUCTION FOR
B/BK/BS/BWT/C/CS/CWT/CK/CX-SERIES PLUNGER PUMPS
on GAS ENGINES with 1-1/8" SHAFTS
REQUIRES 11.5 OZ. ISO VG 220 GEAR LUBE**

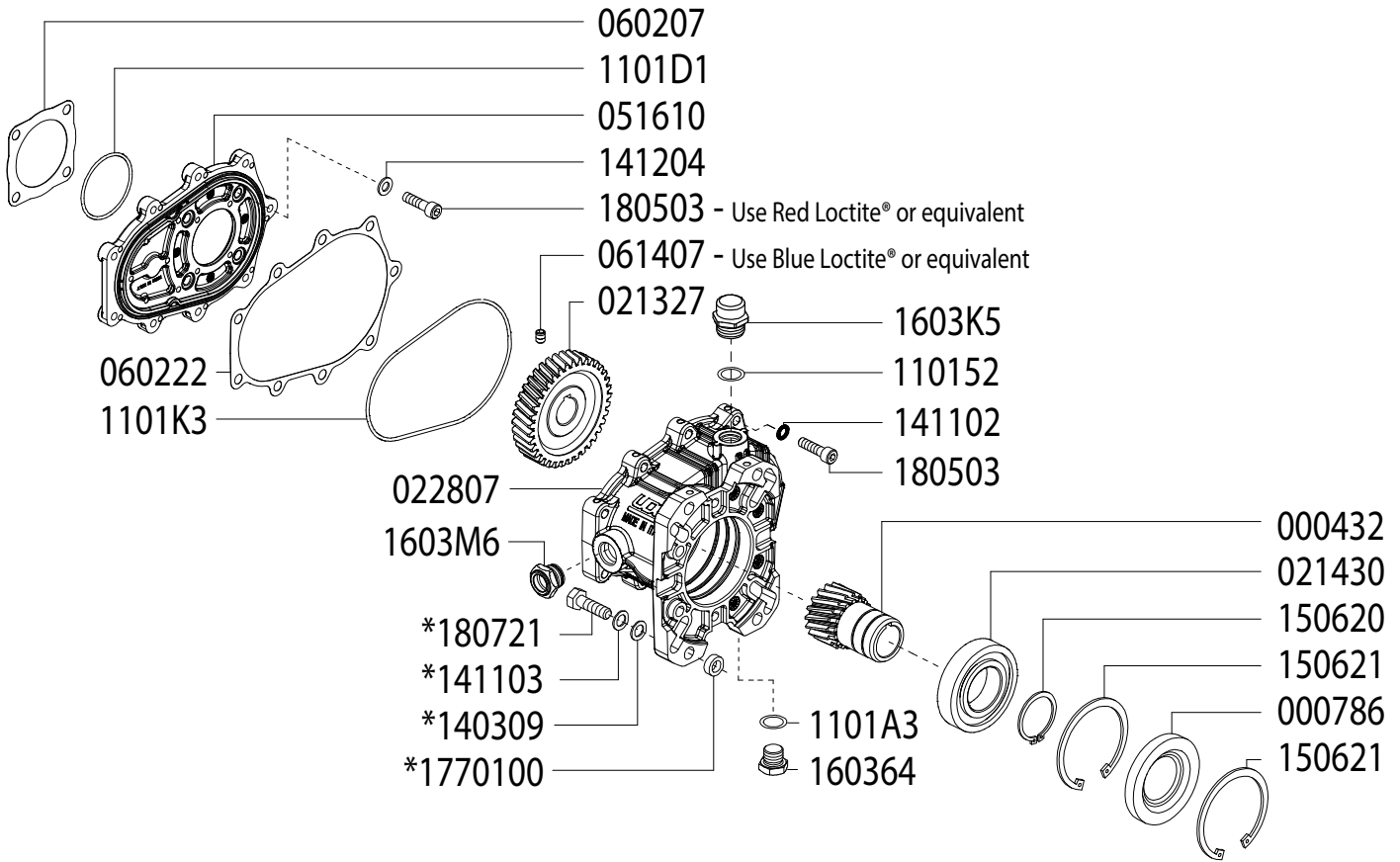

SEE NEXT PAGE FOR ASSEMBLY AND INSTALLATION INSTRUCTIONS

Updated 4-3-2026

Part #	Description	Qty	Part #	Description	Qty
0004.32	GEAR - 1-1/8"	1	*1403.09	WASHER	4
0007.86	OIL SEAL - D40 - RBC122X	1	1411.02	WASHER	9
0213.27	PUMP GEAR	1	*1411.03	SERRATED WASHER	4
0214.30	BEARING - D40 - RBC122X	1	1412.04	WASHER	4
0228.07	COUPLER - RBC122	1	1506.20	SNAP RING - D40	1
0516.10	FLANGE - RBC122	1	1506.21	SNAP RING - D80	2
0602.07	GASKET - RC122	1	1603.64	PLUG - 3/8"	1
0602.22	GASKET - RBC122 HOUSING	1	1603.K5	OIL PLUG - G3/8"	1
0614.07	SET SCREW - M5X8	1	1603.M6	OIL SIGHT GLASS	1
1101.52	O-RING - OIL PLUG	1	1805.03	ALLEN BOLT - M8x30	13
1101.A3	O-RING	1	*1807.21	HEX BOLT - 3/8-16 X 1-1/4"	4
1101.D1	O-RING	1	*17701.00	SPACER	4
1101.K3	O-RING	1			

* For use when using outer mounting holes only

**GAS ENGINE GEAR REDUCTION FOR
B/BK/BS/BWT/C/CS/CWT/CK/CX-SERIES PLUNGER PUMPS
on GAS ENGINES with 1" or 1-1/8" SHAFTS
REQUIRES 11.5 OZ. ISO VG 220 GEAR LUBE**

ASSEMBLY INSTRUCTIONS

- 1 With the pump shaft in vertical position, remove the 4 bolts that affix the bearing flange, leaving it in its position.
- 2 Place the gasket (p/n 060207) on the pump flange and the O-Ring 1101D1 between the pump and the flange (p/n 051610), then attach the flange (p/n 051610) using the Allen Bolts (p/n 180503) with relative bonded seal washers (p/n 141204). Make sure that the O-Ring (p/n 1101K3) is correctly contained in its seat and position the gasket (p/n 060222). Apply Red LOCTITE® (or equivalent) to the bolts (p/n 180503), and tighten with a torque of 19 lb-ft MAX.
- 3 After checking that the key is correctly seated, fit the helical pinion (p/n 021327) on the pump shaft pushing it against the shaft stop and locking it in position with the set screw (p/n 061407), tightening with a torque of 15 lb-ft max (use Blue LOCTITE® or equivalent).
- 4 Complete the assembly of the gearbox crankcase by screwing the oil sight glass (p/n 1603M6) and the plug (p/n 160364) with the corresponding O-Ring (p/n 1101A3).
- 5 Attach the gearbox crankcase assembly to the flange using the (9) Allen Bolts (p/n 180503) and washers (p/n 141102), tightening with a torque of 19 lb-ft MAX.
- 6 Fill the gearbox crankcase with oil (11.5 OZ. ISO VG 220 GEAR LUBE) until the level indicated in the center of the oil sight glass, then closing with the oil plug p/n 1603K5 and O-Ring (p/n 110152).

Note: If the pump-gearbox unit is not immediately coupled to the engine and have to be transported, to avoid possible oil leaks, temporarily use a plug G3/8 (not supplied) instead of the oil plug (p/n 1603K5).

ASSEMBLY OF THE PUMP-GEARBOX UNIT ON THE ENGINE:

- 1 Check that the key of the motor shaft is correctly seated, then apply a good anti-seize lubricant (such as LOCTITE® 8150) to the shaft to facilitate disassembly.
- 2 Then proceed to the coupling of the gearbox to the engine using the appropriate bolts and washers (supplied)
- 3 Tightening torques according to the bolts used.

3/8" - torque = 29 lb-ft MAX

5/16" - torque = 19 lb-ft MAX

*Dimensional Drawings are
Shown in Millimeters.
To Convert to Inches,
Multiply Dimension x 0.03937*

CH SERIES PUMPS - 24mm SOLID SHAFT

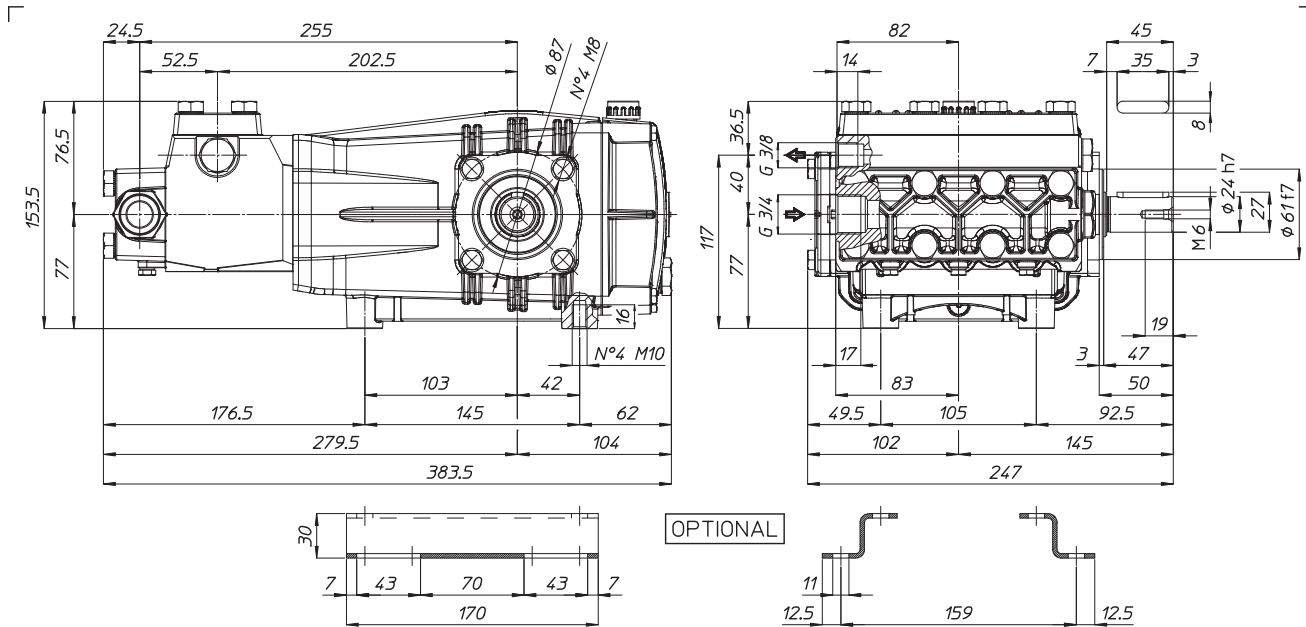

TORQUE SPECS

Ref.	Description	Ft./lb.	Nm	Loctite®
1	Head Bolts	37	50	-
2	Valve Caps	-	-	-
3	Inlet Cap	103	140	-
4	Outlet Cap	60	80	243
5	Bearing Flange Bolts	19	25	-
6	Rear Cover Bolts	8	11	-
7	Connecting Rod Bolts	19	25	270
8	Plunger Bolts	15	20	270
9	Valve Cover Bolts	37	50	-
10	Oil Drain Plug	8	11	-

