

Gear Reduction, Gas Engine Models

1" or 1-1/8" Hollow Shaft, SAE J609-B Flange
2.2:1 Gear Reduction Drive



- Solid Ceramic Plungers
- Stainless Steel Check Valves
- Heavy Duty Brass Manifold with External and Internal Bracing
- High Strength Aluminum Alloy Connecting Rods.
- Large Diameter Brass Valve Caps with Increased Thread Depth
- Reinforcing Ring on Inlet and Discharge Ports
- Deeper Back Cover for Increased Oil Capacity
- 34.5 oz. Capacity Vented Oil Bath Crank Case
- 3/4" BSP-F Inlet. 3/8" BSP-F Outlet: 5.5 - 8.5 GPM
- 3/4" BSP-F Inlet. 1/2" BSP-F Outlet: 9.0 GPM & Above
- Max Fluid Temp, 160°F
- Standard with 1" Hollow Shaft
- Available with 1-1/8" Hollow Shaft.
Add '1-1/8' to Model Number to Specify when Ordering

CC Series 24mm Keyed Solid Shaft Plunger Pumps

CC Series standard duty plunger pumps include a wide range of models with flow rates from 5.5 to 18.5 GPM and pressures up to 2900 PSI.

Other drive options include 24mm solid shaft and hydraulic motor flange.

Applications include general pressure cleaning, sewer jetting, vehicle wash equipment, street cleaning, construction, hydro-excavation and UHP fire fighting applications.

	Model	Flow		Pressure		Plunger Dia.	Crankshaft		Power	Seal Kit	Valve Kit	Wt.
		GPM	l/min	PSI	bar		Stroke	Code				
Gear Reduction	CC 21/20 GR	5.5	21.0	2900	200	22mm	13.5mm	N	14.5 HP Gas	6061.10	6061.03	36 lbs
	CC 26/20 GR	6.9	26.0	2900	200	22mm	17.0mm	X	16.0 HP Gas	6061.10	6061.03	36 lbs
	CC 30/20 GR	7.9	30.0	2900	200	25mm	15.0mm	V	20.0 HP Gas	6061.11	6061.03	36 lbs
	CC 34/20 GR	9.0	34.0	2900	200	25mm	17.0mm	X	23.0 HP Gas	6061.11	6061.03	36 lbs
	CC 38/17 GR	10.0	38.0	2465	170	28mm	15.0mm	V	20.0 HP Gas	6061.12	6061.03	36 lbs
	CC 42/17 GR	11.6	44.0	2465	170	28mm	17.0mm	X	23.0 HP Gas	6061.12	6061.03	36 lbs
	CC 50/15 GR	13.2	50.0	2175	150	28mm	19.0mm	Y	23.0 HP Gas	6061.12	6061.03	36 lbs
	CC 70/15 GR	18.5	70.0	2175	150	30mm	24.0mm	2	35.0 HP Gas	6072.02	6072.26	36 lbs

NOTE: All models available with 1" or 1-1/8" Hollow Shafts. Specify size when ordering (ex. CC 21/20 GR1 or CC 21/20 GR1-1/8.)



MAX FLOW
MAX PRESSURE
RATED PUMP SPEED
POWER REQUIREMENT
LUBRICATION

18.5 GPM / 70.0 L/MIN
2175 PSI / 150 BAR
1450 RPM
35.0 HP GAS
34.5 OZ UDOR LUBE

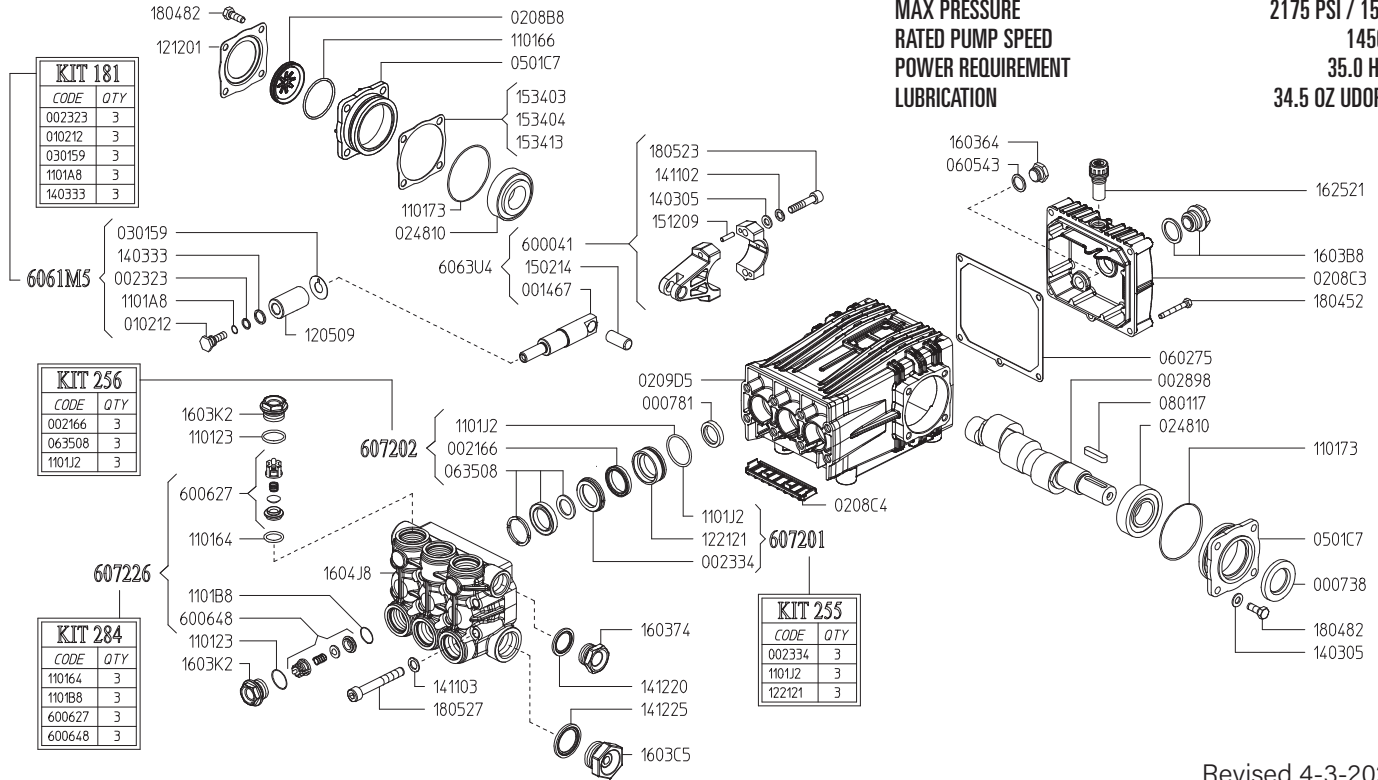

Revised 4-3-2026

Part #	Description	Qty	Part #	Description	Qty
0007.38	OIL SEAL D30	1	1411.02	SERRATED WASHER D8	6
0007.81	OIL SEAL D20	3	1411.03	SERRATED WAHSER D10	8
0014.67	PLUNGER GUIDE D22/25/28 "C/CK"	3	1412.20	GASKET	1
0021.66	WATER SEAL L.P. D30 BPC ^C	3	1412.25	GASKET	1
0023.23	RING D10.4 ^A	3	1502.14	PIN D14X32	3
0023.34	UPPER RING ^B	3	1512.09	PLUG D5X20	6
0028.98	CRANKSHAFT D24	1	1534.03	SHIM 0.1 MM	1
0102.12	PLUNGER BOLT ^A	3	1534.04	SHIM 0.2 MM	1
0208.B8	OIL SIGHT GLASS	1	1534.13	SHIM 0.05 MM	1
0208.C3	BACK COVER "C/CK"	1	1603.64	PLUG - 1/2"	1
0208.C4	COVER "C/CK"	1	1603.74	PLUG G3/4	1
0209.D5	CRANKCASE "C/CK/CH"	1	1603.B8	OIL PLUG G3/4" + GASKET	1
0248.10	ROLLER BEARING D30	2	1603.C5	PLUG G1	2
0301.59	SLINGER RING D22 ^A	3	1603.K2	VALVE CAP	6
0501.C7	BEARING HOLLOW FLANGE	2	1604.J8	HEAD	1
0602.75	BACK COVER GASKET	1	1625.21	OIL PLUG G3/8	1
0605.43	GASKET D17	1	1804.52	HEX BOLT M6X45	5
0635.08	HIGH PRESSURE SEAL KIT ^C	3	1804.82	HEX BOLT M8X22	8
0801.17	KEY A8X7X35	1	1805.23	ALLEN BOLT M8X40	6
1001.38	NIPPLE G3/4 M - 1" M	1	1805.27	ALLEN BOLT	8
1101.23	O-RING - VALVE CAP	6	6000.41	ROD ASSEMBLY	3
1101.64	O-RING - VALVE, DISCHARGE ^D	3	6006.27	VALVE - DISCHARGE ^D	3
1101.66	O-RING - OIL SIGHT GLASS	1	6006.48	VALVE - INLET ^D	3
1101.73	O-RING - BEARING FLANGE	2	6063.U4	COMPLETE ROD ASSEMBLY	3
1101.A8	O-RING - PLUNGER BOLT ^A	3	6061.M5	PLUNGER KIT (KIT 181)	1
1101.B8	O-RING - VALVE, INLET ^D	3	6072.01	BRASS RING KIT (KIT 255)	1
1101.J2	O-RING - PRESSURE RING ^{B,C}	3	6072.02	WATER SEAL KIT (KIT 256)	1
1205.09	CERAMIC PLUNGER	3	6072.26	VALVE KIT (KIT 284)	1
1212.01	RETAINER - OIL SIGHT GLASS	1			
1221.21	PRESSURE RING ^B	3			
1403.05	WASHER D8.4	10			
1403.33	WASHER D13.2 ^A	3			

^A Parts in 6061.M5 (Kit 181).

^B Parts in 6072.01 (Kit 255).

^C Parts in 6072.02 (Kit 256).

^D Parts in 6072.26 (Kit 284).

**GAS ENGINE GEAR REDUCTION FOR
B/BK/BS/BWT/C/CS/CWT/CK/CX-SERIES PLUNGER PUMPS
on GAS ENGINES with 1" SHAFTS
REQUIRES 11.5 OZ. ISO VG 220 GEAR LUBE**

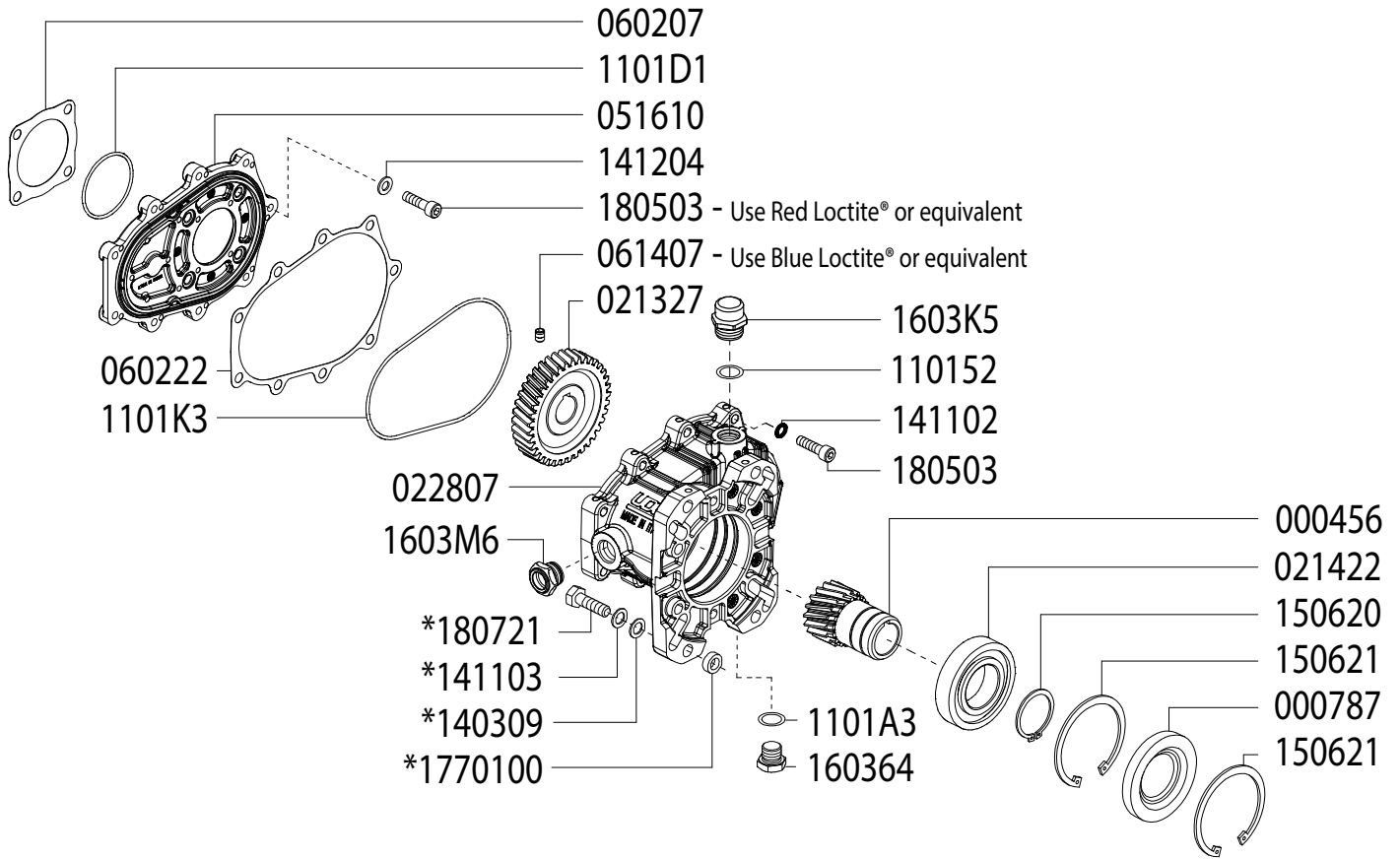

SEE NEXT PAGE FOR ASSEMBLY AND INSTALLATION INSTRUCTIONS

Updated 4-3-2026

Part #	Description	Qty	Part #	Description	Qty
0004.56	GEAR - 1"	1	*1403.09	WASHER	4
0007.87	OIL SEAL - D40 - RBC122K	1	1411.02	WASHER	9
0213.27	PUMP GEAR	1	*1411.03	SERRATED WASHER	4
0214.22	BEARING - D40 - RBC122K	1	1412.04	WASHER	4
0228.07	COUPLER - RBC122	1	1506.20	SNAP RING - D40	1
0516.10	FLANGE - RBC122	1	1506.21	SNAP RING - D80	2
0602.07	GASKET - RC122	1	1603.64	PLUG - 3/8"	1
0602.22	GASKET - RBC122 HOUSING	1	1603.K5	OIL PLUG - G3/8"	1
0614.07	SET SCREW - M5X8	1	1603.M6	OIL SIGHT GLASS	1
1101.52	O-RING - OIL PLUG	1	1805.03	ALLEN BOLT - M8x30	13
1101.A3	O-RING	1	*1807.21	HEX BOLT - 3/8-16 X 1-1/4"	4
1101.D1	O-RING	1	*1770.100	SPACER	4
1101.K3	O-RING	1			

* For use when using outer mounting holes only

**GAS ENGINE GEAR REDUCTION FOR
B/BK/BS/BWT/C/CS/CWT/CK/CX-SERIES PLUNGER PUMPS
on GAS ENGINES with 1-1/8" SHAFTS
REQUIRES 11.5 OZ. ISO VG 220 GEAR LUBE**

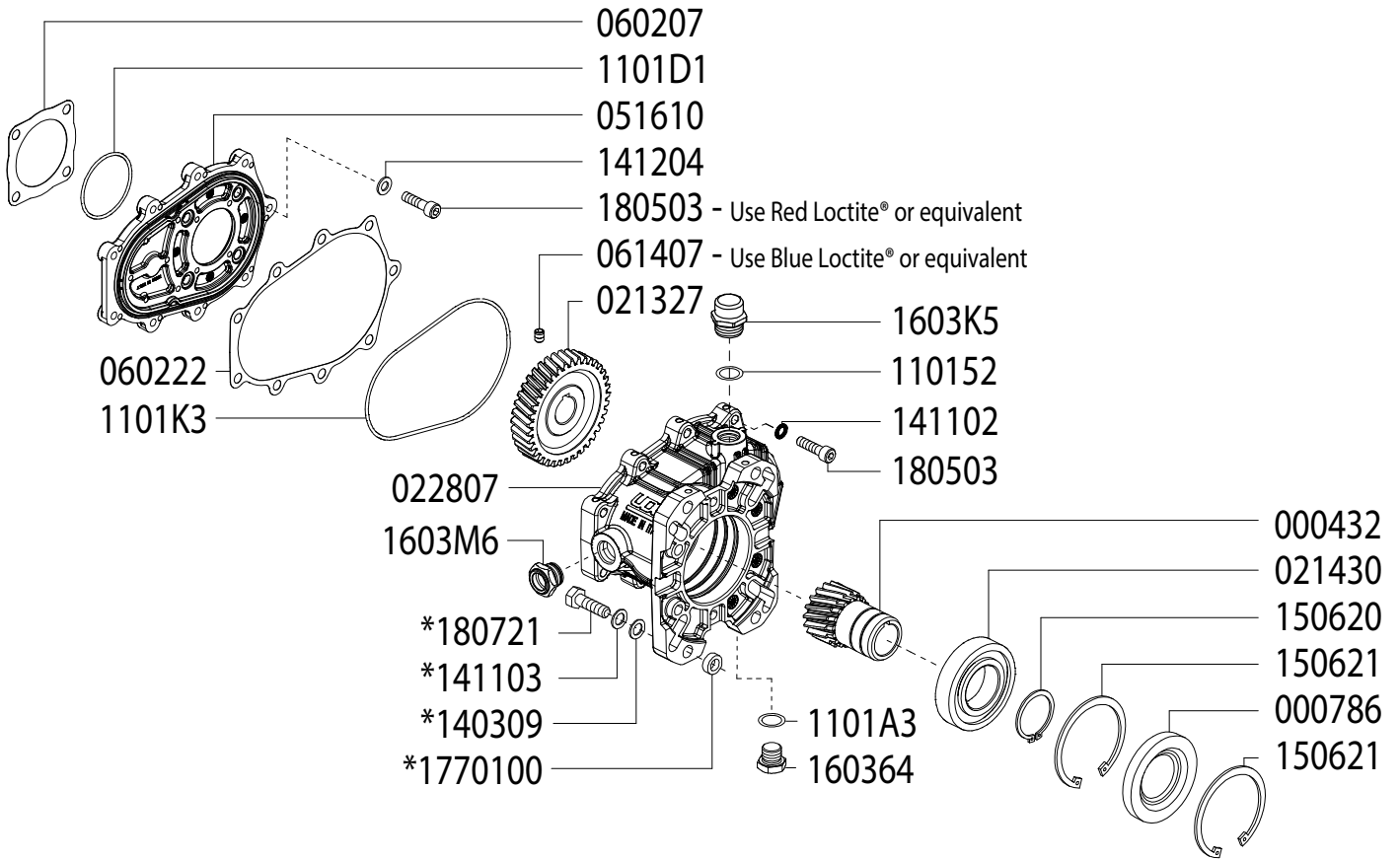

SEE NEXT PAGE FOR ASSEMBLY AND INSTALLATION INSTRUCTIONS

Updated 4-3-2026

Part #	Description	Qty	Part #	Description	Qty
0004.32	GEAR - 1-1/8"	1	*1403.09	WASHER	4
0007.86	OIL SEAL - D40 - RBC122X	1	1411.02	WASHER	9
0213.27	PUMP GEAR	1	*1411.03	SERRATED WASHER	4
0214.30	BEARING - D40 - RBC122X	1	1412.04	WASHER	4
0228.07	COUPLER - RBC122	1	1506.20	SNAP RING - D40	1
0516.10	FLANGE - RBC122	1	1506.21	SNAP RING - D80	2
0602.07	GASKET - RC122	1	1603.64	PLUG - 3/8"	1
0602.22	GASKET - RBC122 HOUSING	1	1603.K5	OIL PLUG - G3/8"	1
0614.07	SET SCREW - M5X8	1	1603.M6	OIL SIGHT GLASS	1
1101.52	O-RING - OIL PLUG	1	1805.03	ALLEN BOLT - M8x30	13
1101.A3	O-RING	1	*1807.21	HEX BOLT - 3/8-16 X 1-1/4"	4
1101.D1	O-RING	1	*17701.00	SPACER	4
1101.K3	O-RING	1			

* For use when using outer mounting holes only



RBC 122K / RBC 122X

8900.11/8900.08

**GAS ENGINE GEAR REDUCTION FOR
B/BK/BS/BWT/C/CS/CWT/CK/CX-SERIES PLUNGER PUMPS
on GAS ENGINES with 1" or 1-1/8" SHAFTS
REQUIRES 11.5 OZ. ISO VG 220 GEAR LUBE**

ASSEMBLY INSTRUCTIONS

- 1 With the pump shaft in vertical position, remove the 4 bolts that affix the bearing flange, leaving it in its position.
- 2 Place the gasket (p/n 060207) on the pump flange and the O-Ring 1101D1 between the pump and the flange (p/n 051610), then attach the flange (p/n 051610) using the Allen Bolts (p/n 180503) with relative bonded seal washers (p/n 141204). Make sure that the O-Ring (p/n 1101K3) is correctly contained in its seat and position the gasket (p/n 060222). Apply Red LOCTITE® (or equivalent) to the bolts (p/n 180503), and tighten with a torque of 19 lb-ft MAX.
- 3 After checking that the key is correctly seated, fit the helical pinion (p/n 021327) on the pump shaft pushing it against the shaft stop and locking it in position with the set screw (p/n 061407), tightening with a torque of 15 lb-ft max (use Blue LOCTITE® or equivalent).
- 4 Complete the assembly of the gearbox crankcase by screwing the oil sight glass (p/n 1603M6) and the plug (p/n 160364) with the corresponding O-Ring (p/n 1101A3).
- 5 Attach the gearbox crankcase assembly to the flange using the (9) Allen Bolts (p/n 180503) and washers (p/n 141102), tightening with a torque of 19 lb-ft MAX.
- 6 Fill the gearbox crankcase with oil (11.5 OZ. ISO VG 220 GEAR LUBE) until the level indicated in the center of the oil sight glass, then closing with the oil plug p/n 1603K5 and O-Ring (p/n 110152).

Note: If the pump-gearbox unit is not immediately coupled to the engine and have to be transported, to avoid possible oil leaks, temporarily use a plug G3/8 (not supplied) instead of the oil plug (p/n 1603K5).

ASSEMBLY OF THE PUMP-GEARBOX UNIT ON THE ENGINE:

- 1 Check that the key of the motor shaft is correctly seated, then apply a good anti-seize lubricant (such as LOCTITE® 8150) to the shaft to facilitate disassembly.
- 2 Then proceed to the coupling of the gearbox to the engine using the appropriate bolts and washers (supplied)
- 3 Tightening torques according to the bolts used.

3/8" - torque = 29 lb-ft MAX

5/16" - torque = 19 lb-ft MAX

WEIGHT
LUBRICATION

36 LBS
34.5 OZ UDOR LUBE

*Dimensional Drawings are
Shown in Millimeters.
To Convert to Inches,
Multiply Dimension x 0.03937*

CC 70/15 S & CD 18.5/22 S

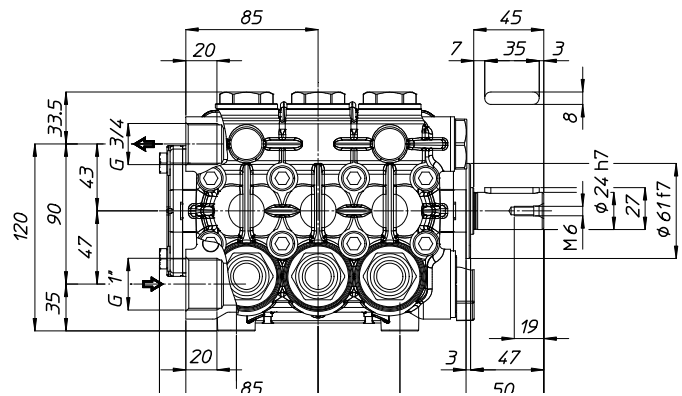
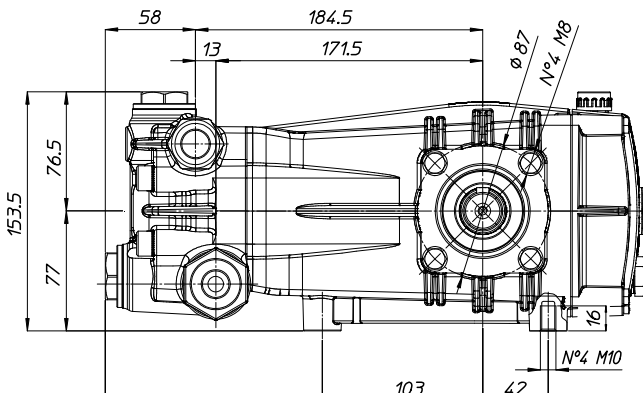

TORQUE SPECS

Ref.	Description	Ft./lb.	Nm	Loctite®
1	Head Bolts	37	50	-
2	Valve Caps	103	140	243
3	Inlet Cap	103	140	-
4	Outlet Cap	103	140	243
5	Bearing Flange Bolts	19	25	-
6	Rear Cover Bolts	8	11	-
7	Connecting Rod Bolts	19	25	270
8	Plunger Bolts	15	20	270
9	Valve Cover Bolts	-	-	-
10	Oil Drain Plug	8	11	-

