

Gear Reduction, Gas Engine Models

1" or 1-1/8" Hollow Shaft, SAE J609-B Flange
2.2:1 Gear Reduction Drive

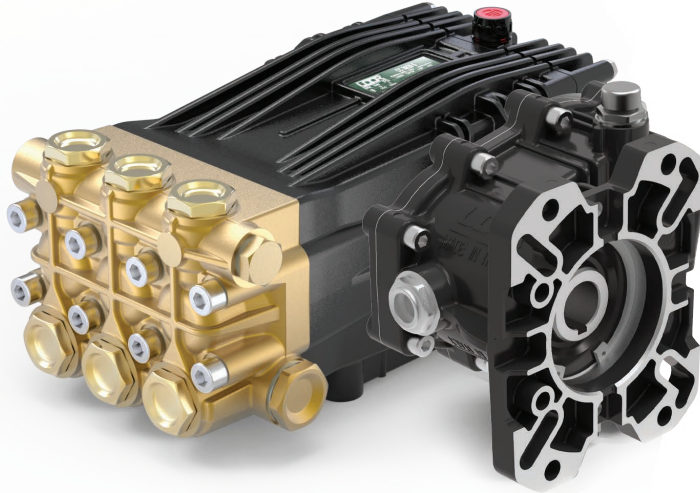

- Solid Ceramic Plungers
- Stainless Steel Check Valves
- Heavy Duty Brass Manifold with External and Internal Bracing
- High Strength Aluminum Alloy Connecting Rods.
- Large Diameter Brass Valve Caps with Increased Thread Depth
- Reinforcing Ring on Inlet and Discharge Ports
- Deeper Back Cover for Increased Oil Capacity
- 34.5 oz. Capacity Vented Oil Bath Crank Case
- 3/4" BSP-F Inlet. 3/8" BSP-F Outlet: 5.5 - 8.5 GPM
- 3/4" BSP-F Inlet. 1/2" BSP-F Outlet: 9.0 GPM & Above
- Max Fluid Temp, 160°F
- Standard with 1" Hollow Shaft
- Available with 1-1/8" Hollow Shaft.
Add '1-1/8' to Model Number to Specify when Ordering

CC Series 24mm Keyed Solid Shaft Plunger Pumps

CC Series standard duty plunger pumps include a wide range of models with flow rates from 5.5 to 18.5 GPM and pressures up to 2900 PSI.

Other drive options include 24mm solid shaft and hydraulic motor flange.

Applications include general pressure cleaning, sewer jetting, vehicle wash equipment, street cleaning, construction, hydro-excavation and UHP fire fighting applications.

	Model	Flow		Pressure		Plunger Dia.	Crankshaft		Power	Seal Kit	Valve Kit	Wt.
		GPM	l/min	PSI	bar		Stroke	Code				
Gear Reduction	CC 21/20 GR	5.5	21.0	2900	200	22mm	13.5mm	N	14.5 HP Gas	6061.10	6061.03	36 lbs
	CC 26/20 GR	6.9	26.0	2900	200	22mm	17.0mm	X	16.0 HP Gas	6061.10	6061.03	36 lbs
	CC 30/20 GR	7.9	30.0	2900	200	25mm	15.0mm	V	20.0 HP Gas	6061.11	6061.03	36 lbs
	CC 34/20 GR	9.0	34.0	2900	200	25mm	17.0mm	X	23.0 HP Gas	6061.11	6061.03	36 lbs
	CC 38/17 GR	10.0	38.0	2465	170	28mm	15.0mm	V	20.0 HP Gas	6061.12	6061.03	36 lbs
	CC 42/17 GR	11.6	44.0	2465	170	28mm	17.0mm	X	23.0 HP Gas	6061.12	6061.03	36 lbs
	CC 50/15 GR	13.2	50.0	2175	150	28mm	19.0mm	Y	23.0 HP Gas	6061.12	6061.03	36 lbs
	CC 70/15 GR	18.5	70.0	2175	150	30mm	24.0mm	2	35.0 HP Gas	6072.02	6072.26	36 lbs

NOTE: All models available with 1" or 1-1/8" Hollow Shafts. Specify size when ordering (ex. **CC 21/20 GR1** or **CC 21/20 GR1-1/8.**)



MAX FLOW
MAX PRESSURE
RATED PUMP SPEED
POWER REQUIREMENT
LUBRICATION

9.0 GPM / 34.0 L/MIN
2900 PSI / 200 BAR
1450 RPM
20.0 HP GAS
34.5 OZ UDOR LUBE

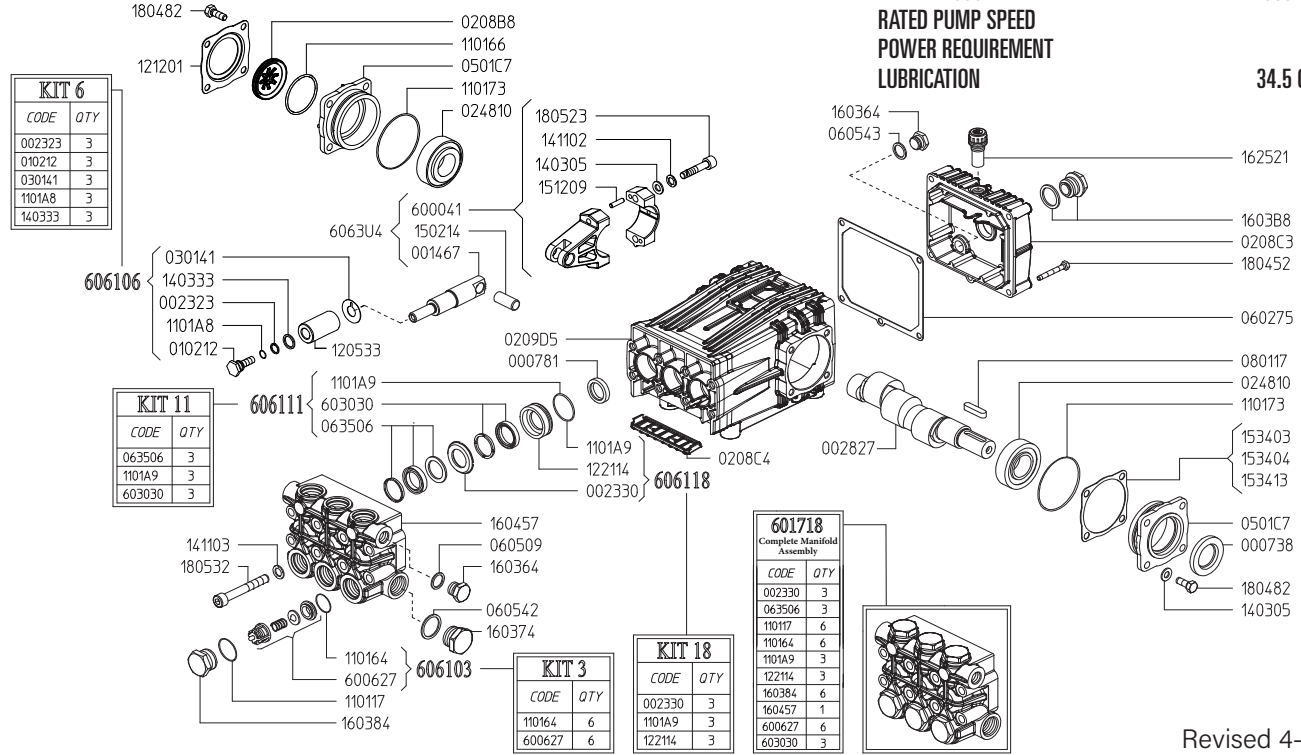

Revised 4-3-2026

Part #	Description	Qty	Part #	Description	Qty
0007.38	OIL SEAL D30	1	1411.02	SERATED WASHER D8	6
0007.81	OIL SEAL D20	3	1411.03	SERATED WAHSER D10	8
0014.67	PLUNGER GUIDE D22/25/28 "C/CK"	3	1502.14	PIN D14X32	3
0023.23	RING D10.4 ^B	3	1512.09	PLUG D5X20 UNI1707	6
0023.29	UPPER RING D25 ^{D E}	3	1534.03	SHIM 0.1 MM	1
0028.27	MALE SHAFT D24	1	1534.04	SHIM 0.2 MM	1
0102.12	PLUNGER BOLT ^B	3	1534.13	SHIM 0.05 MM	1
0208.B8	OIL SIGHT GLASS	1	1603.64	PLUG G3/8	2
0208.C3	BACK COVER "C/CK"	1	1603.74	PLUG G3/4	1
0208.C4	COVER "C/CK"	1	1603.84	VALVE PLUG PISTON D22/25 ^E	6
0209.D5	CRANKCASE "C/CK/CH"	1	1603.B8	OIL PLUG G3/4" + GASKET	1
0248.10	ROLLER BEARING D30	2	1604.57	HEAD "C/G" PISTON D22/25 ^E	1
0301.41	SLINGER RING ^B	3	1625.21	OIL PLUG G3/8	1
0501.C7	BEARING HOLLOW FLANGE	2	1804.52	HEX BOLT M6X45	5
0602.75	BACK COVER GASKET	1	1804.82	HEX BOLT M8X22	8
0605.09	GASKET D17	1	1805.23	ALLEN BOLT M8X40	6
0605.42	GASKET D27	1	1805.32	ALLEN BOLT M10X75	8
0605.43	GASKET D17	1	6000.41	ROD ASSEMBLY	3
0635.06	HIGH PRESSURE SEAL KIT D25 ^C	3	6006.27	VALVE ASSEMBLY W/O O-RING ^{A E}	6
0801.17	KEY A8X7X35	1	6017.18	COMPLETE MANIFOLD ASSEMBLY	1
1101.17	O-RING - VALVE PLUG ^E	6	6030.30	LOW PRESSURE SEAL KIT D25 ^{C E}	3
1101.64	O-RING - VALVE ^{A E}	6	6063.U4	COMPLETE ROD ASSEMBLY	3
1101.66	O-RING - OIL SIGHT GLASS	1	6061.03	KIT 3 VALVE KIT	1
1101.73	O-RING - BEARING FLANGE	2	6061.06	KIT 6 PLUNGER KIT	1
1101.A8	O-RING - PLUNGER BOLT ^B	3	6061.11	KIT 11 WATER SEAL KIT D25 "C/CK"	1
1101.A9	O-RING - PRESSURE RING ^{C D E}	3	6061.18	KIT 18 BRASS RING KIT D25 "C/CK/CW"	1
1205.33	CERAMIC PLUNGER D25	3			
1212.01	RETAINER - OIL SIGHT GLASS	1			
1221.14	PRESSURE RING D25 ^{D E}	3			
1403.05	WASHER D8.4	10			
1403.33	WASHER D13.4 ^B	3			

^A Parts in 6061.03 (Kit 3).
^B Parts in 6061.06 (Kit 6).
^C Parts in 6061.11 (Kit 11).
^D Parts in 6061.18 (Kit 18).
^E Parts in 6017.18 (Complete Manifold Assembly).

**GAS ENGINE GEAR REDUCTION FOR
B/BK/BS/BWT/C/CS/CWT/CK/CX-SERIES PLUNGER PUMPS
on GAS ENGINES with 1" SHAFTS
REQUIRES 11.5 OZ. ISO VG 220 GEAR LUBE**

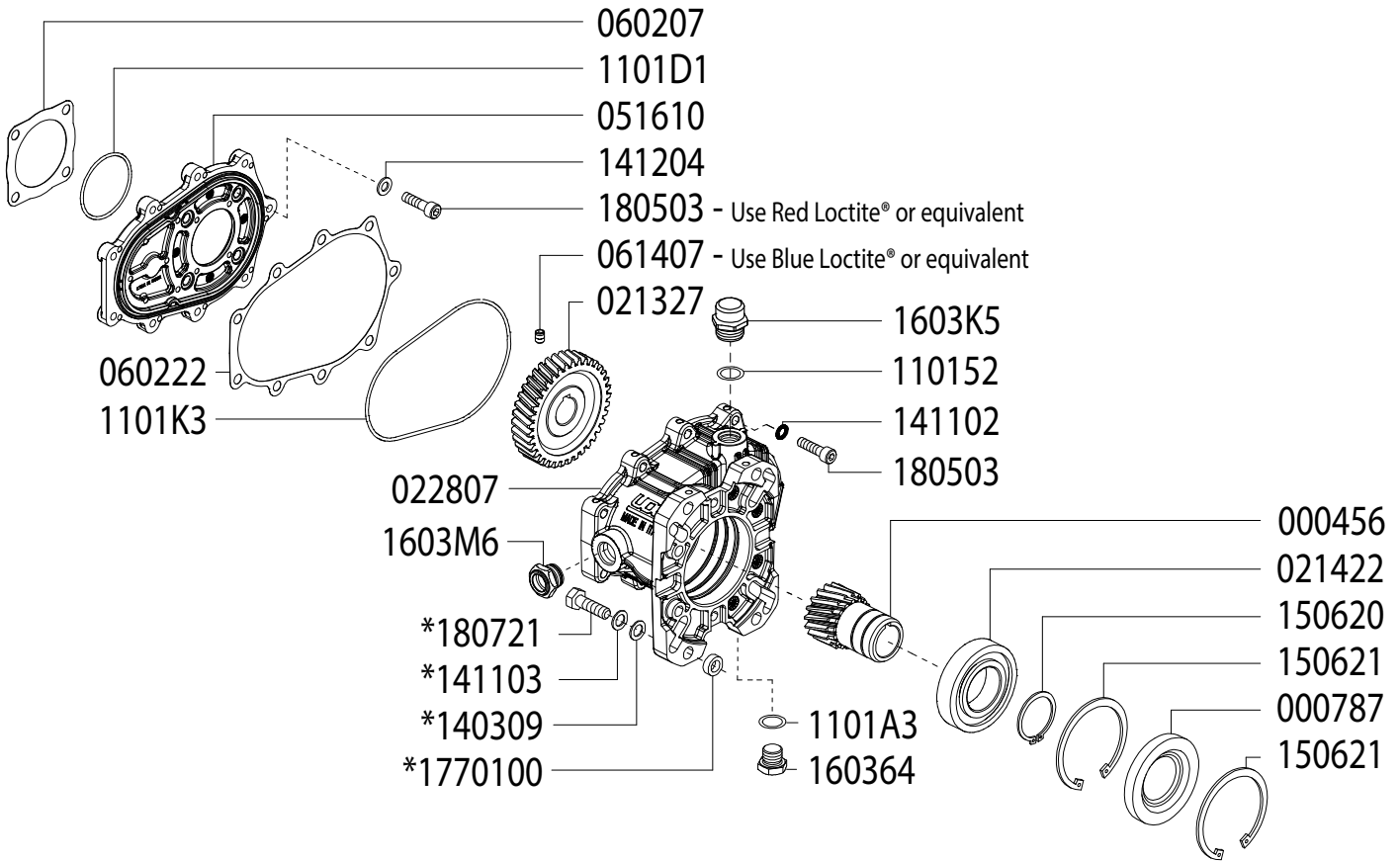

SEE NEXT PAGE FOR ASSEMBLY AND INSTALLATION INSTRUCTIONS

Updated 4-3-2026

Part #	Description	Qty	Part #	Description	Qty
0004.56	GEAR - 1"	1	*1403.09	WASHER	4
0007.87	OIL SEAL - D40 - RBC122K	1	1411.02	WASHER	9
0213.27	PUMP GEAR	1	*1411.03	SERRATED WASHER	4
0214.22	BEARING - D40 - RBC122K	1	1412.04	WASHER	4
0228.07	COUPLER - RBC122	1	1506.20	SNAP RING - D40	1
0516.10	FLANGE - RBC122	1	1506.21	SNAP RING - D80	2
0602.07	GASKET - RC122	1	1603.64	PLUG - 3/8"	1
0602.22	GASKET - RBC122 HOUSING	1	1603.K5	OIL PLUG - G3/8"	1
0614.07	SET SCREW - M5X8	1	1603.M6	OIL SIGHT GLASS	1
1101.52	O-RING - OIL PLUG	1	1805.03	ALLEN BOLT - M8x30	13
1101.A3	O-RING	1	*1807.21	HEX BOLT - 3/8-16 X 1-1/4"	4
1101.D1	O-RING	1	*1770.100	SPACER	4
1101.K3	O-RING	1			

* For use when using outer mounting holes only

**GAS ENGINE GEAR REDUCTION FOR
B/BK/BS/BWT/C/CS/CWT/CK/CX-SERIES PLUNGER PUMPS
on GAS ENGINES with 1-1/8" SHAFTS
REQUIRES 11.5 OZ. ISO VG 220 GEAR LUBE**

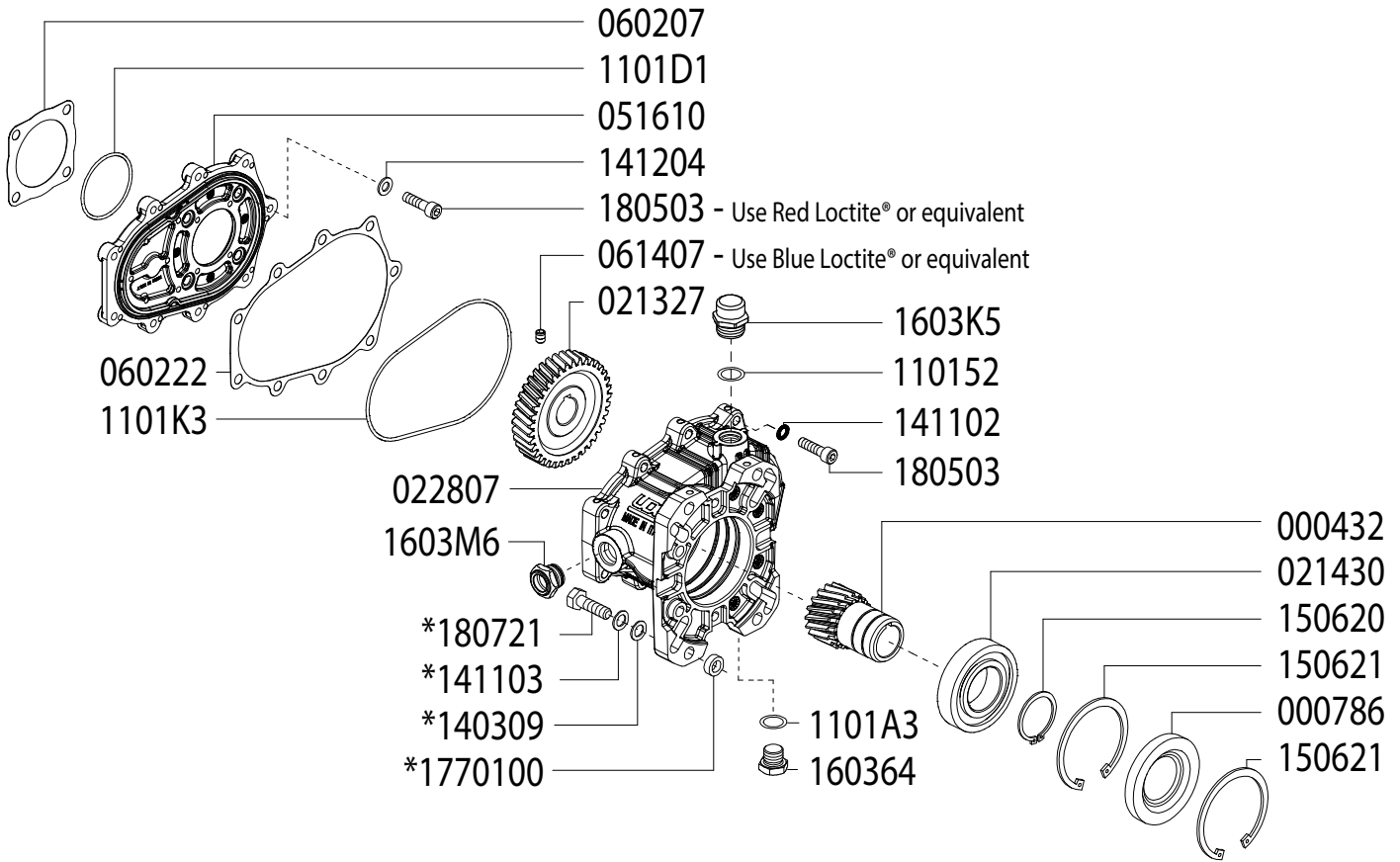

SEE NEXT PAGE FOR ASSEMBLY AND INSTALLATION INSTRUCTIONS

Updated 4-3-2026

Part #	Description	Qty	Part #	Description	Qty
0004.32	GEAR - 1-1/8"	1	*1403.09	WASHER	4
0007.86	OIL SEAL - D40 - RBC122X	1	1411.02	WASHER	9
0213.27	PUMP GEAR	1	*1411.03	SERRATED WASHER	4
0214.30	BEARING - D40 - RBC122X	1	1412.04	WASHER	4
0228.07	COUPLER - RBC122	1	1506.20	SNAP RING - D40	1
0516.10	FLANGE - RBC122	1	1506.21	SNAP RING - D80	2
0602.07	GASKET - RC122	1	1603.64	PLUG - 3/8"	1
0602.22	GASKET - RBC122 HOUSING	1	1603.K5	OIL PLUG - G3/8"	1
0614.07	SET SCREW - M5X8	1	1603.M6	OIL SIGHT GLASS	1
1101.52	O-RING - OIL PLUG	1	1805.03	ALLEN BOLT - M8x30	13
1101.A3	O-RING	1	*1807.21	HEX BOLT - 3/8-16 X 1-1/4"	4
1101.D1	O-RING	1	*17701.00	SPACER	4
1101.K3	O-RING	1			

* For use when using outer mounting holes only

**GAS ENGINE GEAR REDUCTION FOR
B/BK/BS/BWT/C/CS/CWT/CK/CX-SERIES PLUNGER PUMPS
on GAS ENGINES with 1" or 1-1/8" SHAFTS
REQUIRES 11.5 OZ. ISO VG 220 GEAR LUBE**

ASSEMBLY INSTRUCTIONS

- 1 With the pump shaft in vertical position, remove the 4 bolts that affix the bearing flange, leaving it in its position.
- 2 Place the gasket (p/n 060207) on the pump flange and the O-Ring 1101D1 between the pump and the flange (p/n 051610), then attach the flange (p/n 051610) using the Allen Bolts (p/n 180503) with relative bonded seal washers (p/n 141204). Make sure that the O-Ring (p/n 1101K3) is correctly contained in its seat and position the gasket (p/n 060222). Apply Red LOCTITE® (or equivalent) to the bolts (p/n 180503), and tighten with a torque of 19 lb-ft MAX.
- 3 After checking that the key is correctly seated, fit the helical pinion (p/n 021327) on the pump shaft pushing it against the shaft stop and locking it in position with the set screw (p/n 061407), tightening with a torque of 15 lb-ft max (use Blue LOCTITE® or equivalent).
- 4 Complete the assembly of the gearbox crankcase by screwing the oil sight glass (p/n 1603M6) and the plug (p/n 160364) with the corresponding O-Ring (p/n 1101A3).
- 5 Attach the gearbox crankcase assembly to the flange using the (9) Allen Bolts (p/n 180503) and washers (p/n 141102), tightening with a torque of 19 lb-ft MAX.
- 6 Fill the gearbox crankcase with oil (11.5 OZ. ISO VG 220 GEAR LUBE) until the level indicated in the center of the oil sight glass, then closing with the oil plug p/n 1603K5 and O-Ring (p/n 110152).

Note: If the pump-gearbox unit is not immediately coupled to the engine and have to be transported, to avoid possible oil leaks, temporarily use a plug G3/8 (not supplied) instead of the oil plug (p/n 1603K5).

ASSEMBLY OF THE PUMP-GEARBOX UNIT ON THE ENGINE:

- 1 Check that the key of the motor shaft is correctly seated, then apply a good anti-seize lubricant (such as LOCTITE® 8150) to the shaft to facilitate disassembly.
- 2 Then proceed to the coupling of the gearbox to the engine using the appropriate bolts and washers (supplied)
- 3 Tightening torques according to the bolts used.

3/8" - torque = 29 lb-ft MAX

5/16" - torque = 19 lb-ft MAX

WEIGHT
LUBRICATION

36 LBS
34.5 OZ UDOR LUBE

*Dimensional Drawings are
Shown in Millimeters.
To Convert to Inches,
Multiply Dimension x 0.03937*

C SERIES PUMPS 9 GPM & OVER

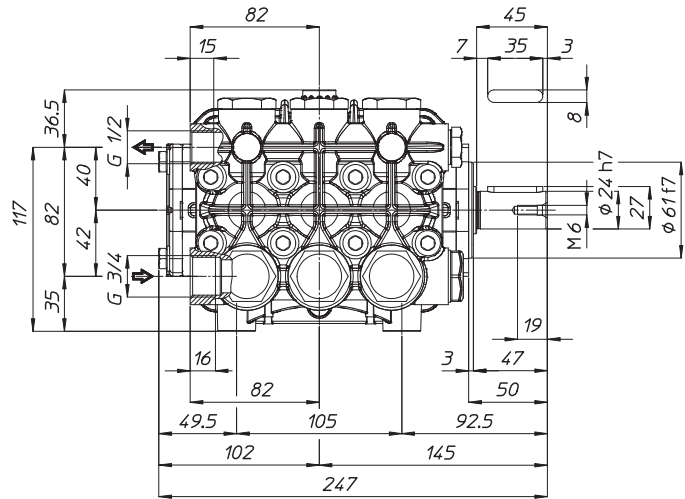
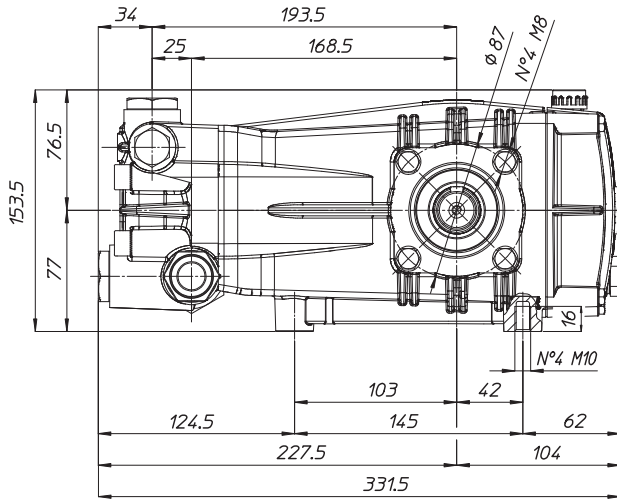

TORQUE SPECS

Ref.	Description	Ft./lb.	Nm	Loctite®
1	Head Bolts	37	50	-
2	Valve Caps	103	140	243
3	Inlet Cap	103	140	-
4	Outlet Cap	103	140	243
5	Bearing Flange Bolts	19	25	-
6	Rear Cover Bolts	8	11	-
7	Connecting Rod Bolts	19	25	270
8	Plunger Bolts	15	20	270
9	Valve Cover Bolts	-	-	-
10	Oil Drain Plug	8	11	-

