

Gear Reduction, Gas Engine Models

1" or 1-1/8" Hollow Shaft, SAE J609-B Flange.
2.2:1 Gear Reduction Drive

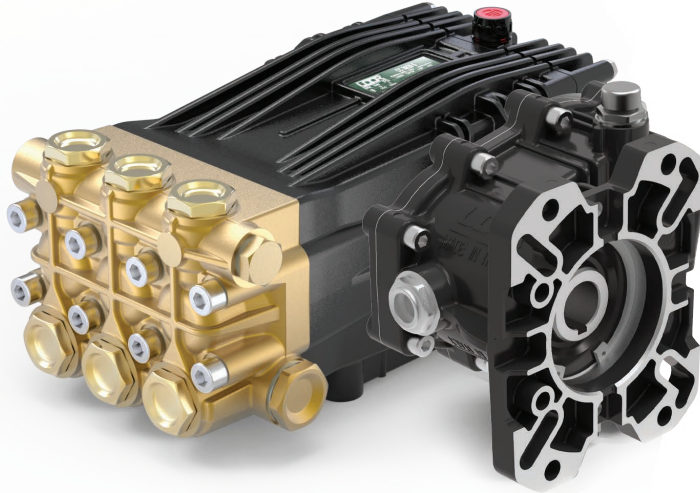

- Solid Ceramic Plungers
- Stainless Steel Check Valves
- Heavy Duty Brass Manifold with External and Internal Bracing
- High Strength Aluminum Alloy Connecting Rods.
- Large Diameter Brass Valve Caps with Increased Thread Depth
- Reinforcing Ring on Inlet and Discharge Ports
- Deeper Back Cover for Increased Oil Capacity
- 34.5 oz. Capacity Vented Oil Bath Crank Case
- 3/4" BSP-F Inlet. 3/8" BSP-F Outlet: 5.5 - 8.5 GPM
- 3/4" BSP-F Inlet. 1/2" BSP-F Outlet: 9.0 GPM & Above
- Max Fluid Temp, 160°F
- Standard with 1" Hollow Shaft
- Available with 1-1/8" Hollow Shaft.
Add '1-1/8' to Model Number to Specify when Ordering

CC Series 24mm Keyed Solid Shaft Plunger Pumps

CC Series standard duty plunger pumps include a wide range of models with flow rates from 5.5 to 18.5 GPM and pressures up to 2900 PSI.

Other drive options include 24mm solid shaft and hydraulic motor flange.

Applications include general pressure cleaning, sewer jetting, vehicle wash equipment, street cleaning, construction, hydro-excavation and UHP fire fighting applications.

| | Model | Flow | | Pressure | | Plunger Dia. | Crankshaft | | Power | Seal Kit | Valve Kit | Wt. |
|----------------|-------------|------|-------|----------|-----|--------------|------------|------|-------------|----------|-----------|--------|
| | | GPM | l/min | PSI | bar | | Stroke | Code | | | | |
| Gear Reduction | CC 21/20 GR | 5.5 | 21.0 | 2900 | 200 | 22mm | 13.5mm | N | 14.5 HP Gas | 6061.10 | 6061.03 | 36 lbs |
| | CC 26/20 GR | 6.9 | 26.0 | 2900 | 200 | 22mm | 17.0mm | X | 16.0 HP Gas | 6061.10 | 6061.03 | 36 lbs |
| | CC 30/20 GR | 7.9 | 30.0 | 2900 | 200 | 25mm | 15.0mm | V | 20.0 HP Gas | 6061.11 | 6061.03 | 36 lbs |
| | CC 34/20 GR | 9.0 | 34.0 | 2900 | 200 | 25mm | 17.0mm | X | 23.0 HP Gas | 6061.11 | 6061.03 | 36 lbs |
| | CC 38/17 GR | 10.0 | 38.0 | 2465 | 170 | 28mm | 15.0mm | V | 20.0 HP Gas | 6061.12 | 6061.03 | 36 lbs |
| | CC 42/17 GR | 11.6 | 44.0 | 2465 | 170 | 28mm | 17.0mm | X | 23.0 HP Gas | 6061.12 | 6061.03 | 36 lbs |
| | CC 50/15 GR | 13.2 | 50.0 | 2175 | 150 | 28mm | 19.0mm | Y | 23.0 HP Gas | 6061.12 | 6061.03 | 36 lbs |
| | CC 70/15 GR | 18.5 | 70.0 | 2175 | 150 | 30mm | 24.0mm | 2 | 35.0 HP Gas | 6072.02 | 6072.26 | 36 lbs |

NOTE: All models available with 1" or 1-1/8" Hollow Shafts. Specify size when ordering (ex. CC 21/20 GR1 or CC 21/20 GR1-1/8.)



MAX FLOW
MAX PRESSURE
RATED PUMP SPEED
POWER REQUIREMENT
LUBRICATION

6.9 GPM / 26.0 L/MIN
2900 PSI / 200 BAR
1450 RPM
16.0 HP GAS
34.5 OZ UDOR LUBE

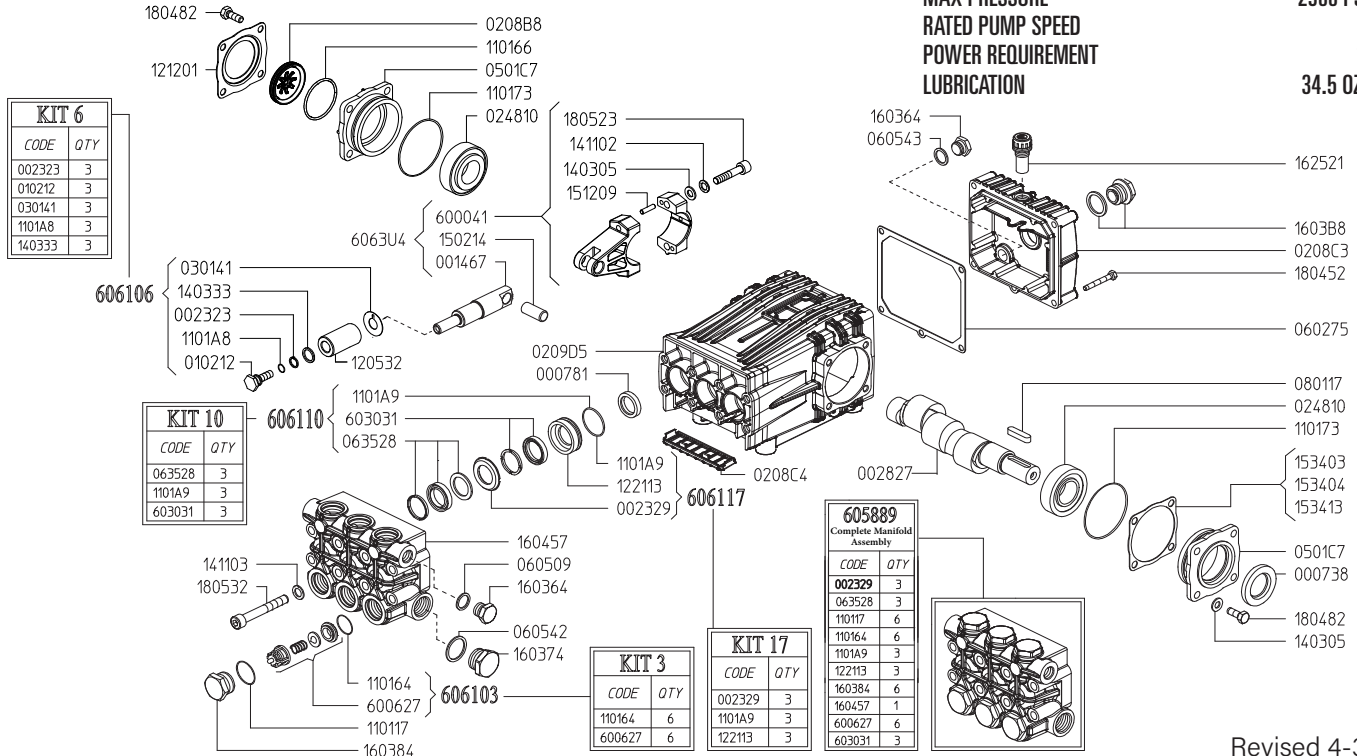

Revised 4-3-2026

| Part # | Description | Qty |
|---------|-------------------------------------------|-----|
| 0007.38 | OIL SEAL D30 | 1 |
| 0007.81 | OIL SEAL D20 | 3 |
| 0014.67 | PLUNGER GUIDE D22/25/28 "C/CK" | 3 |
| 0023.23 | RING D10.4 ^B | 3 |
| 0023.29 | UPPER RING D20 "M/MK" ^{C D E} | 3 |
| 0028.27 | MALE SHAFT D24 | 1 |
| 0102.12 | PLUNGER BOLT ^B | 3 |
| 0208.B8 | OIL SIGHT GLASS | 1 |
| 0208.C3 | BACK COVER "C/CK" | 1 |
| 0208.C4 | COVER "C/CK" | 1 |
| 0209.D5 | CRANKCASE "C/CK/CH" | 1 |
| 0248.10 | ROLLER BEARING D30 | 2 |
| 0301.41 | SLINGER RING ^B | 3 |
| 0501.C7 | BEARING HOLLOW FLANGE | 2 |
| 0602.75 | BACK COVER GASKET | 1 |
| 0605.09 | GASKET D17 | 1 |
| 0605.42 | GASKET D27 | 1 |
| 0605.43 | GASKET D17 | 1 |
| 0635.28 | HIGH PRESSURE SEAL KIT D22 ^{C E} | 3 |
| 0801.17 | KEY A8X7X35 | 1 |
| 1101.17 | O-RING - VALVE PLUG ^E | 6 |
| 1101.64 | O-RING - VALVE ^{A E} | 6 |
| 1101.66 | O-RING - OIL SIGHT GLASS | 1 |
| 1101.73 | O-RING - BEARING FLANGE | 2 |
| 1101.A8 | O-RING - PLUNGER BOLT ^B | 3 |
| 1101.A9 | O-RING - PRESSURE RING ^{C D E} | 3 |
| 1205.32 | CERAMIC PLUNGER D22 | 3 |
| 1212.01 | RETAINER - OIL SIGHT GLASS | 1 |
| 1221.13 | PRESSURE RING D22 ^{D E} | 3 |
| 1403.05 | WASHER D8.4 | 10 |
| 1403.33 | WASHER D13.4 ^B | 3 |

| Part # | Description | Qty |
|---------|------------------------------------------|-----|
| 1411.02 | SERATED WASHER D8 | 6 |
| 1411.03 | SERATED WAHSER D10 | 8 |
| 1502.14 | PIN D14X32 | 3 |
| 1512.09 | PLUG D5X20 UNI1707 | 6 |
| 1534.03 | SHIM 0.1 MM | 1 |
| 1534.04 | SHIM 0.2 MM | 1 |
| 1534.13 | SHIM 0.05 MM | 1 |
| 1603.64 | PLUG G3/8 | 2 |
| 1603.74 | PLUG G3/4 | 1 |
| 1603.84 | VALVE PLUG PISTON D22/25 ^E | 6 |
| 1603.B8 | OIL PLUG G3/4" + GASKET | 1 |
| 1604.57 | HEAD "C/G" PISTON D22/25 ^E | 1 |
| 1625.21 | OIL PLUG G3/8 | 1 |
| 1804.52 | HEX BOLT M6X45 | 5 |
| 1804.82 | HEX BOLT M8X22 | 8 |
| 1805.23 | ALLEN BOLT M8X40 | 6 |
| 1805.32 | ALLEN BOLT M10X75 | 8 |
| 6000.41 | ROD ASSEMBLY | 3 |
| 6006.27 | VALVE ASSEMBLY W/O O-RING ^{A E} | 6 |
| 6030.31 | LOW PRESSURE SEAL ASSY D22 ^C | 3 |
| 6058.89 | COMPLETE MANIFOLD ASSEMBLY | 1 |
| 6063.U4 | COMPLETE ROD ASSEMBLY | 3 |
| 6061.03 | KIT 3 VALVE KIT | 1 |
| 6061.06 | KIT 6 PLUNGER KIT | 1 |
| 6061.10 | KIT 10 WATER SEAL KIT D22 "C/CK" | 1 |
| 6061.17 | KIT 17 BRASS RING KIT D22 "C/CK/NX" | 1 |

^A Parts in 6061.03 (Kit 3).

^B Parts in 6061.06 (Kit 6).

^C Parts in 6061.10 (Kit 10).

^D Parts in 6061.17 (Kit 17).

^E Parts in 6058.89 (Complete Manifold Assembly).

**GAS ENGINE GEAR REDUCTION FOR
B/BK/BS/BWT/C/CS/CWT/CK/CX-SERIES PLUNGER PUMPS
on GAS ENGINES with 1" SHAFTS
REQUIRES 11.5 OZ. ISO VG 220 GEAR LUBE**

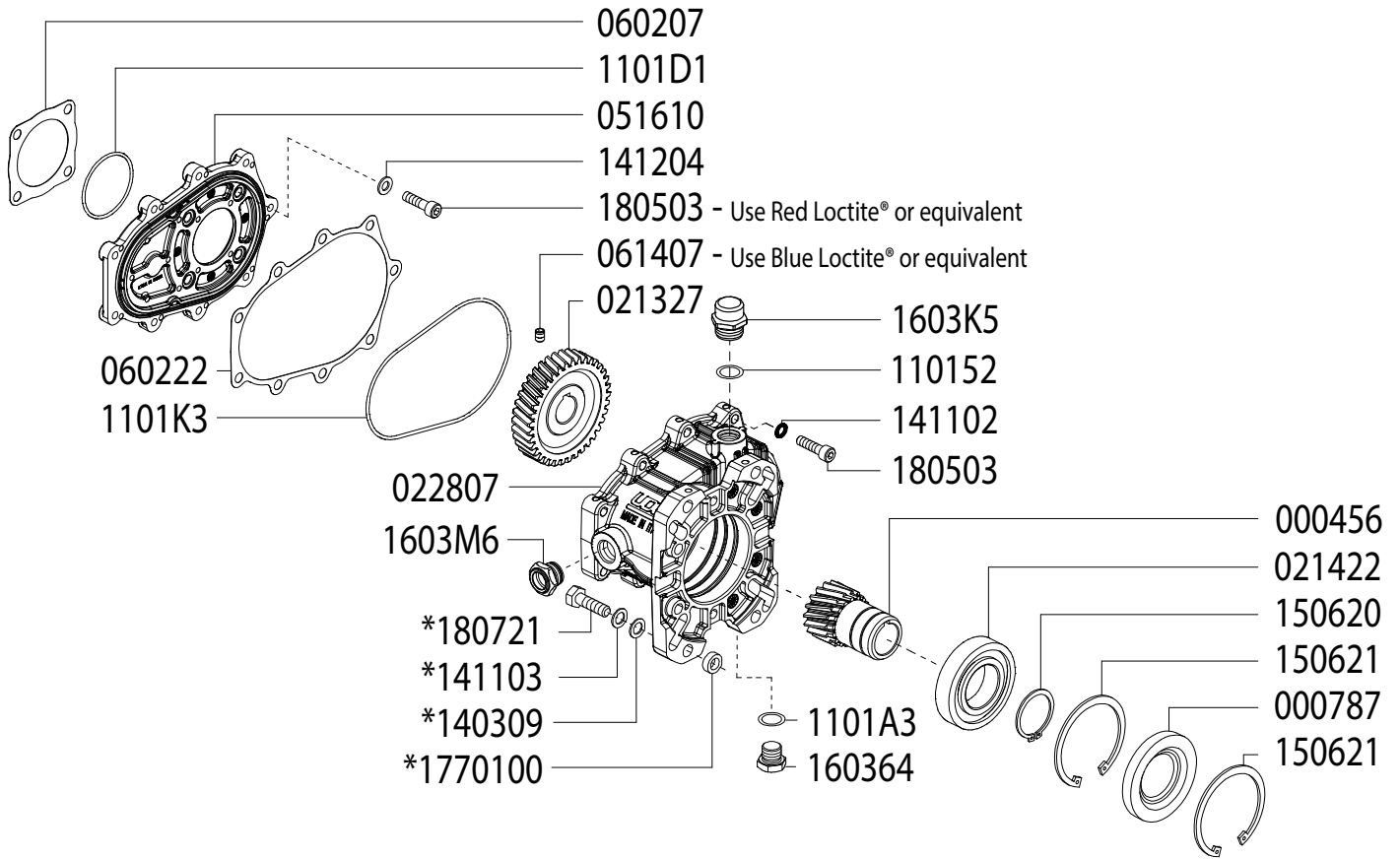

SEE NEXT PAGE FOR ASSEMBLY AND INSTALLATION INSTRUCTIONS

Updated 4-3-2026

| Part # | Description | Qty | Part # | Description | Qty |
|---------|--------------------------|-----|----------|----------------------------|-----|
| 0004.56 | GEAR - 1" | 1 | *1403.09 | WASHER | 4 |
| 0007.87 | OIL SEAL - D40 - RBC122K | 1 | 1411.02 | WASHER | 9 |
| 0213.27 | PUMP GEAR | 1 | *1411.03 | SERRATED WASHER | 4 |
| 0214.22 | BEARING - D40 - RBC122K | 1 | 1412.04 | WASHER | 4 |
| 0228.07 | COUPLER - RBC122 | 1 | 1506.20 | SNAP RING - D40 | 1 |
| 0516.10 | FLANGE - RBC122 | 1 | 1506.21 | SNAP RING - D80 | 2 |
| 0602.07 | GASKET - RC122 | 1 | 1603.64 | PLUG - 3/8" | 1 |
| 0602.22 | GASKET - RBC122 HOUSING | 1 | 1603.K5 | OIL PLUG - G3/8" | 1 |
| 0614.07 | SET SCREW - M5X8 | 1 | 1603.M6 | OIL SIGHT GLASS | 1 |
| 1101.52 | O-RING - OIL PLUG | 1 | 1805.03 | ALLEN BOLT - M8x30 | 13 |
| 1101.A3 | O-RING | 1 | *1807.21 | HEX BOLT - 3/8-16 X 1-1/4" | 4 |
| 1101.D1 | O-RING | 1 | *1770.00 | SPACER | 4 |
| 1101.K3 | O-RING | 1 | | | |

* For use when using outer mounting holes only

**GAS ENGINE GEAR REDUCTION FOR
B/BK/BS/BWT/C/CS/CWT/CK/CX-SERIES PLUNGER PUMPS
on GAS ENGINES with 1-1/8" SHAFTS
REQUIRES 11.5 OZ. ISO VG 220 GEAR LUBE**

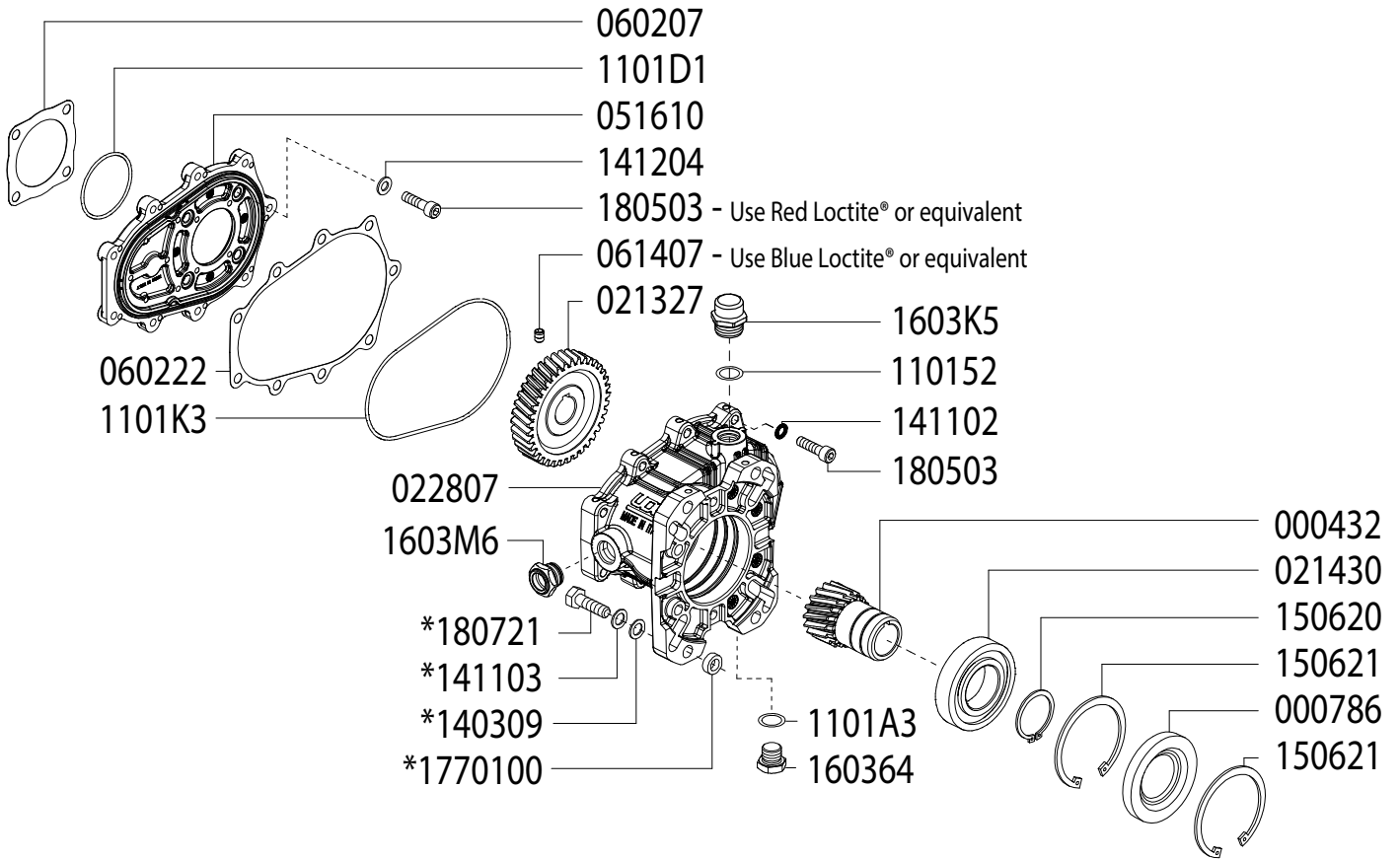

SEE NEXT PAGE FOR ASSEMBLY AND INSTALLATION INSTRUCTIONS

Updated 4-3-2026

| Part # | Description | Qty | Part # | Description | Qty |
|---------|--------------------------|-----|-----------|----------------------------|-----|
| 0004.32 | GEAR - 1-1/8" | 1 | *1403.09 | WASHER | 4 |
| 0007.86 | OIL SEAL - D40 - RBC122X | 1 | 1411.02 | WASHER | 9 |
| 0213.27 | PUMP GEAR | 1 | *1411.03 | SERRATED WASHER | 4 |
| 0214.30 | BEARING - D40 - RBC122X | 1 | 1412.04 | WASHER | 4 |
| 0228.07 | COUPLER - RBC122 | 1 | 1506.20 | SNAP RING - D40 | 1 |
| 0516.10 | FLANGE - RBC122 | 1 | 1506.21 | SNAP RING - D80 | 2 |
| 0602.07 | GASKET - RC122 | 1 | 1603.64 | PLUG - 3/8" | 1 |
| 0602.22 | GASKET - RBC122 HOUSING | 1 | 1603.K5 | OIL PLUG - G3/8" | 1 |
| 0614.07 | SET SCREW - M5X8 | 1 | 1603.M6 | OIL SIGHT GLASS | 1 |
| 1101.52 | O-RING - OIL PLUG | 1 | 1805.03 | ALLEN BOLT - M8x30 | 13 |
| 1101.A3 | O-RING | 1 | *1807.21 | HEX BOLT - 3/8-16 X 1-1/4" | 4 |
| 1101.D1 | O-RING | 1 | *17701.00 | SPACER | 4 |
| 1101.K3 | O-RING | 1 | | | |

* For use when using outer mounting holes only



RBC 122K / RBC 122X

8900.11/8900.08

**GAS ENGINE GEAR REDUCTION FOR
B/BK/BS/BWT/C/CS/CWT/CK/CX-SERIES PLUNGER PUMPS
on GAS ENGINES with 1" or 1-1/8" SHAFTS
REQUIRES 11.5 OZ. ISO VG 220 GEAR LUBE**

ASSEMBLY INSTRUCTIONS

- 1 With the pump shaft in vertical position, remove the 4 bolts that affix the bearing flange, leaving it in its position.
- 2 Place the gasket (p/n 060207) on the pump flange and the O-Ring 1101D1 between the pump and the flange (p/n 051610), then attach the flange (p/n 051610) using the Allen Bolts (p/n 180503) with relative bonded seal washers (p/n 141204). Make sure that the O-Ring (p/n 1101K3) is correctly contained in its seat and position the gasket (p/n 060222). Apply Red LOCTITE® (or equivalent) to the bolts (p/n 180503), and tighten with a torque of 19 lb-ft MAX.
- 3 After checking that the key is correctly seated, fit the helical pinion (p/n 021327) on the pump shaft pushing it against the shaft stop and locking it in position with the set screw (p/n 061407), tightening with a torque of 15 lb-ft max (use Blue LOCTITE® or equivalent).
- 4 Complete the assembly of the gearbox crankcase by screwing the oil sight glass (p/n 1603M6) and the plug (p/n 160364) with the corresponding O-Ring (p/n 1101A3).
- 5 Attach the gearbox crankcase assembly to the flange using the (9) Allen Bolts (p/n 180503) and washers (p/n 141102), tightening with a torque of 19 lb-ft MAX.
- 6 Fill the gearbox crankcase with oil (11.5 OZ. ISO VG 220 GEAR LUBE) until the level indicated in the center of the oil sight glass, then closing with the oil plug p/n 1603K5 and O-Ring (p/n 110152).

Note: If the pump-gearbox unit is not immediately coupled to the engine and have to be transported, to avoid possible oil leaks, temporarily use a plug G3/8 (not supplied) instead of the oil plug (p/n 1603K5).

ASSEMBLY OF THE PUMP-GEARBOX UNIT ON THE ENGINE:

- 1 Check that the key of the motor shaft is correctly seated, then apply a good anti-seize lubricant (such as LOCTITE® 8150) to the shaft to facilitate disassembly.
- 2 Then proceed to the coupling of the gearbox to the engine using the appropriate bolts and washers (supplied)
- 3 Tightening torques according to the bolts used.

3/8" - torque = 29 lb-ft MAX

5/16" - torque = 19 lb-ft MAX

WEIGHT
LUBRICATION

36 LBS
34.5 OZ UDOR LUBE

*Dimensional Drawings are
Shown in Millimeters.
To Convert to Inches,
Multiply Dimension x 0.03937*

C SERIES PUMPS BELOW 9 GPM

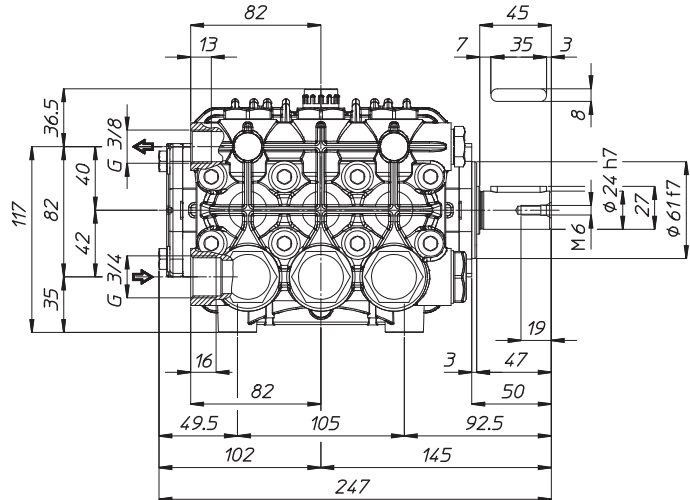
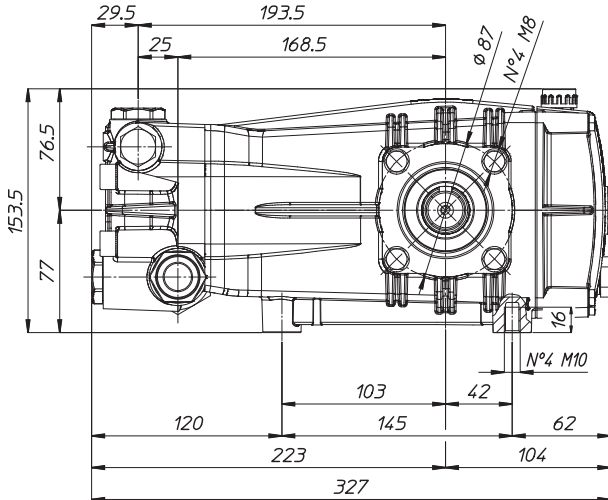

TORQUE SPECS

| Ref. | Description | Ft./lb. | Nm | Loctite® |
|------|----------------------|---------|-----|----------|
| 1 | Head Bolts | 37 | 50 | - |
| 2 | Valve Caps | 103 | 140 | 243 |
| 3 | Inlet Cap | 103 | 140 | - |
| 4 | Outlet Cap | 103 | 140 | 243 |
| 5 | Bearing Flange Bolts | 19 | 25 | - |
| 6 | Rear Cover Bolts | 8 | 11 | - |
| 7 | Connecting Rod Bolts | 19 | 25 | 270 |
| 8 | Plunger Bolts | 15 | 20 | 270 |
| 9 | Valve Cover Bolts | - | - | - |
| 10 | Oil Drain Plug | 8 | 11 | - |

