

- 316 Stainless Steel Manifolds
- 316 Stainless Steel Valves
- 316 Stainless Steel Plunger Rods & Nuts
- 304 Stainless Steel Exterior Bolts
- Solid Ceramic Plungers
- PTFE Style Packings
- 15.4 oz. Capacity Vented Oil Bath Crank Case
- 1/2" BSP-F Inlet. 3/8" BSP-F Outlet
- Max Fluid Temp, 160°F

### BSC Series 24mm Keyed Solid Shaft Plunger Pumps

BSC Series stainless steel plunger pumps include a wide range of models with flow rates from 4.0 to 5.5 GPM and pressures up to 2900 PSI.

These pumps feature stainless steel wetted and exterior components to withstand the harsh environment of salt water applications.

BSC Series pumps are well suited for de-salination, disinfecting and food/pharma applications.

	Model	Flow		Pressure		Plunger Dia.	Crankshaft		Power	Seal Kit	Valve Kit	Wt.
		GPM	l/min	PSI	bar		Stroke	Code				
1450 RPM	BSC 15/20 S	4.0	15.0	2900	200	18mm	14.5mm	I	7.7 EBHP	6700.01	6930.01	26 lbs
	BSC 18/20 S	4.9	18.5	2900	200	18mm	18.0mm	9	9.5 EBHP	6700.01	6930.01	26 lbs
	BSC 21/20 S	5.5	21.0	2900	200	18mm	19.0mm	Y	10.8 EBHP	6700.01	6930.01	26 lbs

All Models available with Gas Engine Gear Reductions. Contact UDOR USA for pricing and availability.



MAX FLOW  
MAX PRESSURE  
RATED PUMP SPEED  
POWER REQUIREMENT  
LUBRICATION

4.0 GPM / 15 L/MIN  
3000 PSI / 200 BAR  
1450 RPM  
8.0 HP ELECTRIC  
15.4 OZ UDOR LUBE

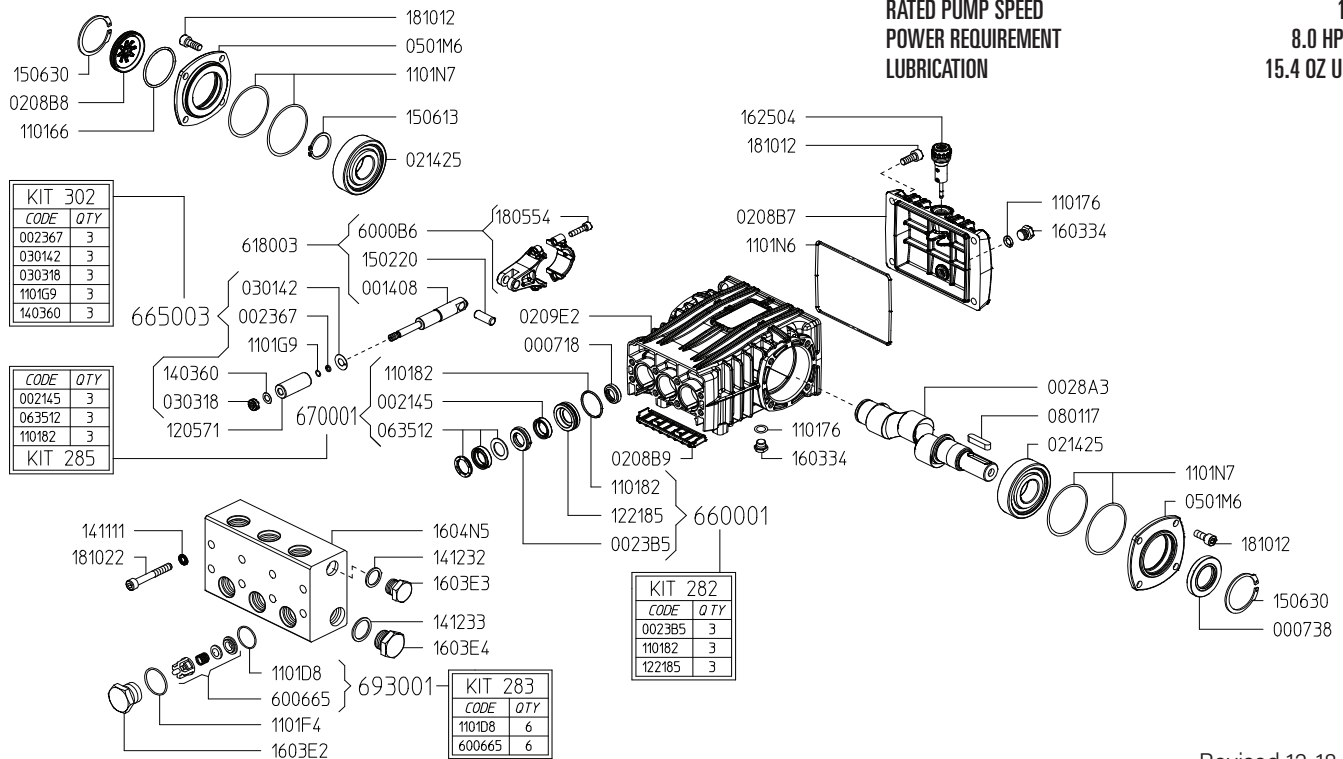

Revised 12-18-2023

Part	Description	Qty	Part	Description	Qty
0007.18	OIL SEAL	3	1403.60	WASHER D8 <sup>A</sup>	3
0007.38	OIL SEAL	1	1411.01	SERRATED WASHER	6
0014.08	PLUNGER ROD	3	1411.11	WASHER	8
0021.45	WATER SEAL LP D18 <sup>B</sup>	3	1412.32	GASKET - DISCHARGE PLUG	1
0023.67	RING D5.2X8X1.3 <sup>A</sup>	3	1412.33	GASKET - INLET PLLUG	1
0023.B5	UPPER RING D18 SS <sup>D</sup>	3	14810.12	ALLEN BOLT - SS	4
0028.A3	CRANKSHAFT	1	1502.20	PIN	3
0208.B6	OIL SIGHT GLASS	1	1506.09	SNAP RING	2
0208.B7	BACK COVER	1	1506.13	SNAP RING	1
0208.B9	PLATE	1	1603.34	OIL DRAIN PLUG	2
0209.E2	CRANKCASE	1	1603.E2	VALVE PLUG - SS	6
0214.25	BEARING	2	1603.E3	PLUG - DISCHARGE	1
0301.42	SLINGER RING <sup>A</sup>	3	1603.E4	PLUG - INLET	1
0303.18	NUT M8XH5 <sup>A</sup>	3	1604.N5	HEAD - SS	1
0501.M6	BEARING RETAINER	2	1625.04	OIL PLUG	1
0635.12	HIGH PRESSURE SEAL ASS'Y D18 <sup>B</sup>	3	1810.12	ALLEN BOLT - SS	8
0801.17	KEY	1	1810.22	ALLEN BOLT - SS	8
0805.54	ALLEN BOLT - SS	6	6006.65	VALVE ASSEMBLY W/O O-RING <sup>C</sup>	3
1101.66	O-RING - OIL SIGHT GLASS	1	6006.B6	CONNECTING ROD	3
1101.76	O-RING - OIL DRAIN PLUG	2	6180.03	CONNECTING ROD ASS'Y COMPLETE	3
1101.82	O-RING - PRESSURE RING <sup>B,D</sup>	3	6700.01	WATER SEAL KIT (KIT 285)	1
1101.D8	O-RING - VALVE <sup>C</sup>	3	6650.03	PLUNGER BOLT KIT (KIT 302)	1
1101.F4	O-RING - VALVE PLUG	6	6600.01	SS RING KIT (KIT 282)	1
1101.G9	O-RING - PLUNGER ROD <sup>A</sup>	3	6930.01	VALVE KIT (KIT 283)	1
1101.N6	O-RING - BACK COVER	1			
1101.N7	O-RING - BEARING RETAINER	4			
1205.71	CERAMIC PLUNGER D18	3			
1221.85	PRESSURE RING D18 SS <sup>D</sup>	3			

<sup>A</sup> Parts in 6650.03 (Kit 302).  
<sup>B</sup> Parts in 6700.01 (KIT 285).  
<sup>C</sup> Parts in 6930.01 (Kit 283).  
<sup>D</sup> Parts in 6600.01 (Kit 282).

*Dimensional Drawings are  
Shown in Millimeters.  
To Convert to Inches,  
Multiply Dimension x 0.03937*

## BS SERIES PUMPS - 24MM SOLID SHAFT

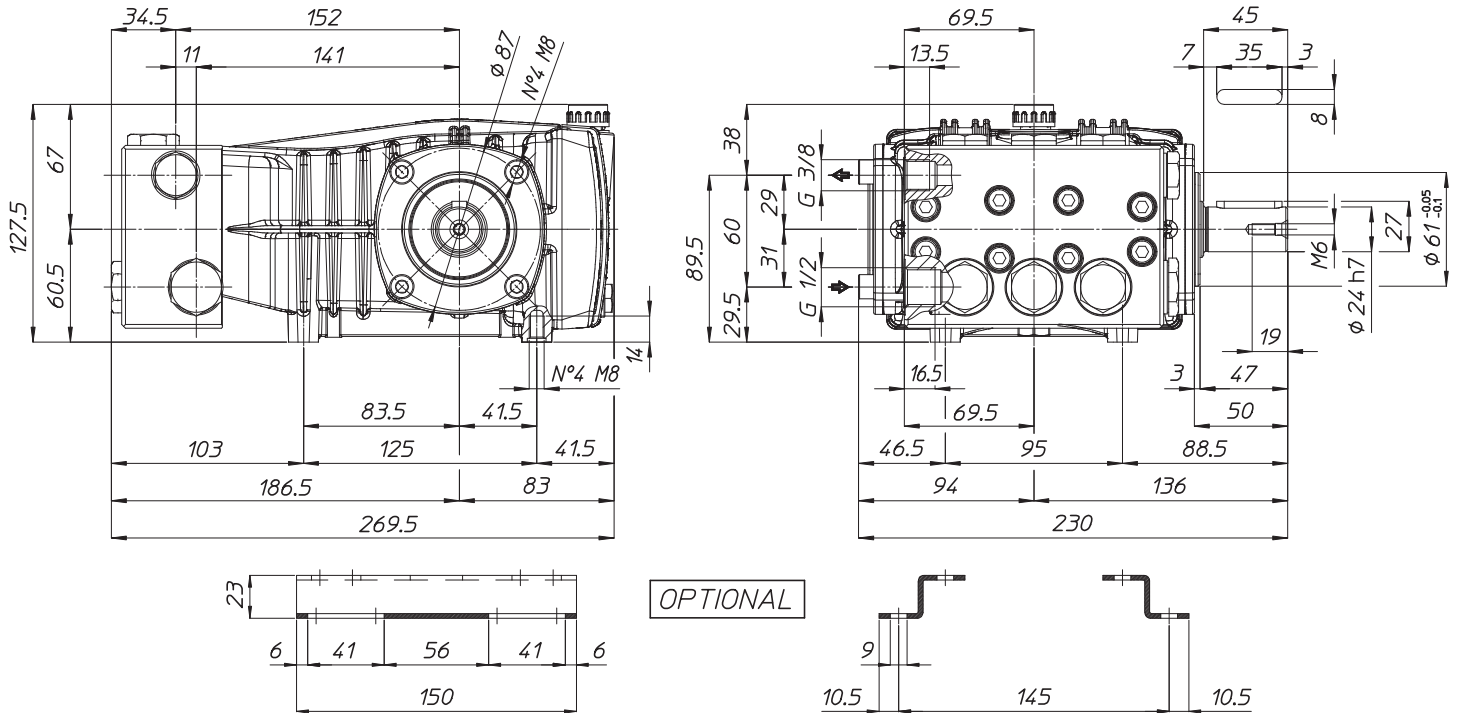

## TORQUE SPECS

Ref.	Description	Ft./lb.	Nm	Loctite®
1	Head Bolts	19	25	-
2	Valve Caps	75	100	243
3	Inlet Cap	75	100	243
4	Outlet Cap	60	80	243
5	Bearing Flange Bolts	19	25	-
6	Rear Cover Bolts	19	25	-
7	Connecting Rod Bolts	9	11	243
8	Plunger Bolts	11	15	270
9	Valve Cover Bolts	-	-	-
10	Oil Drain Plug	19	25	-

