

## Gear Reduction, Gas Engine Models

1" or 1-1/8" Hollow Shaft, SAE J609-B Flange. 2.2:1 Gear Reduction  
Gear Reduction Drive



- Heavy Duty Brass Manifold with External and Internal Bracing
- Heavy Duty Bronze or High Strength Aluminum Alloy Connecting Rods.
- Large Diameter Brass Valve Caps with Increased Thread Depth
- Reinforcing Ring on Inlet and Discharge Ports
- Deeper Back Cover for Increased Oil Capacity
- 15.4 oz. Capacity Vented Oil Bath Crank Case
- 1/2" BSP-F Inlet. 3/8" BSP-F Outlet
- Max Fluid Temp, 160°F

### BKC Series Gas Engine, Gear Reduction Drive Plunger Pumps

BKC Series super duty plunger pumps include a wide range of models with flow rates from 3.4 to 5.5 GPM and pressures up to 4350 PSI.

Other drive options include 24mm solid shaft, gas engine flange and hydraulic motor flange.

Applications include general pressure cleaning, sewer jetting, vehicle wash equipment and UHP fire fighting applications.

	Model	Flow		Pressure		Plunger Dia.	Crankshaft		Power	Seal Kit	Valve Kit	Wt.
		GPM	l/min	PSI	bar		Stroke	Code				
Gear Reduction	BKC 13/30 GR	3.4	13.0	4350	300	15mm	18.0mm	9	14.5 HP Gas	6061.B2	6061.30	30 lbs
	BKC 15/30 GR	4.0	15.0	4350	300	18mm	14.5mm	I	16 HP Gas	6061.28	6061.30	30 lbs
	BKC 18/25 GR	4.9	18.5	3625	250	18mm	18.0mm	9	16 HP Gas	6061.28	6061.30	30 lbs
	BKC 21/25 GR	5.5	21.0	3625	250	18mm	19.0mm	Y	18 HP Gas	6061.28	6061.30	30 lbs

**NOTE:** All models available with 1" or 1-1/8" Hollow Shafts . Specify size when ordering (ex. BKC 13/30 GR1 or BKC 13/30 GR1-1/8.)



MAX FLOW  
MAX PRESSURE  
RATED PUMP SPEED  
POWER REQUIREMENT  
LUBRICATION

5.5 GPM / 21.0 L/MIN  
3625 PSI / 250 BAR  
1450 RPM  
18.0 HP GAS  
15.4 OZ UDOR LUBE

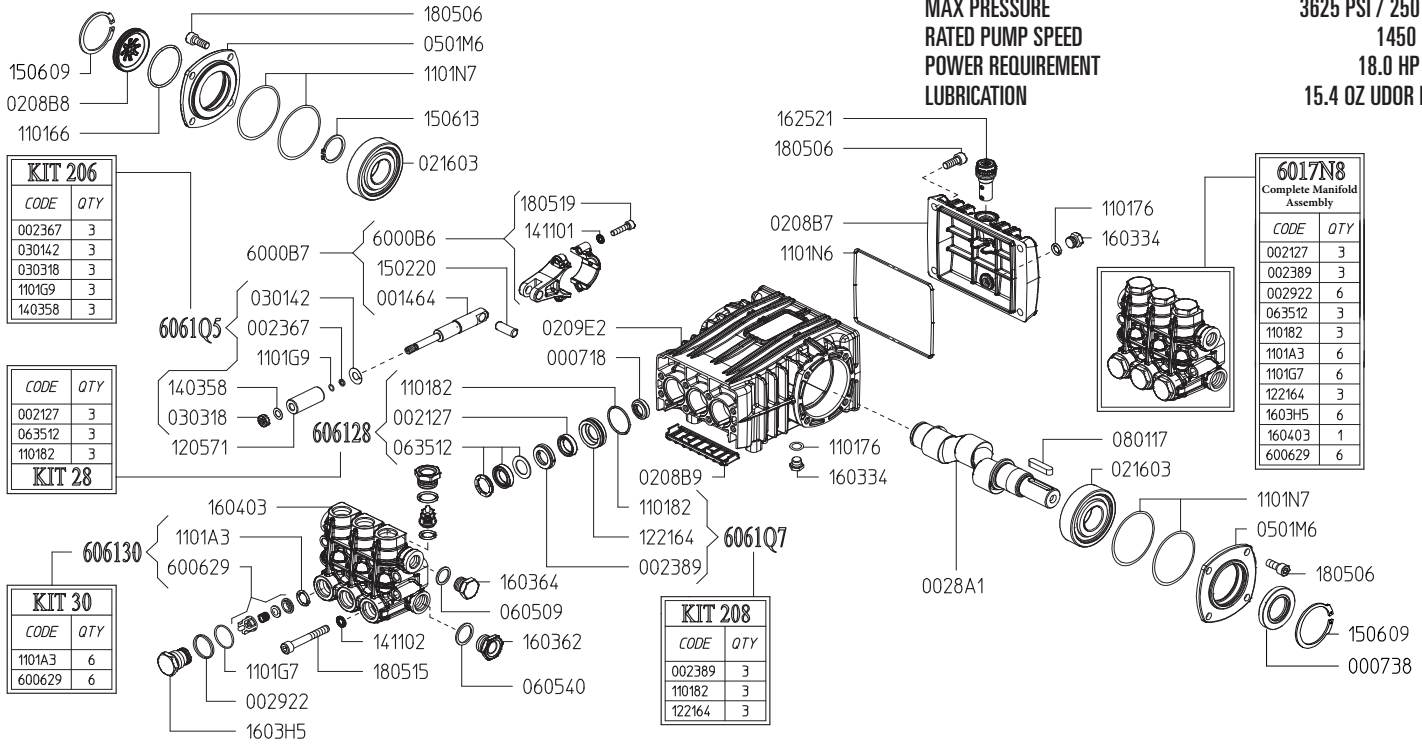

Revised 4-2-2026

Part #	Description	Qty	Part #	Description	Qty
0007.18	OIL SEAL D15X24X5	3	1205.71	CERAMIC PLUNGER D18 "B/BK"	3
0007.38	OIL SEAL D30	1	1221.64	PRESSURE RING D18 "B/BK" <sup>D E</sup>	3
0014.64	PLUNGER GUIDE "B/BK"	3	1403.58	WASHER D8 <sup>C</sup>	3
0021.27	WATER SEAL LP D18 <sup>B E</sup>	3	1411.01	SERATED WASHER D6	6
0023.67	RING D5.2X8X1.3 <sup>C</sup>	3	1411.02	SERATED WASHER D8	8
0023.89	UPPER RING D18 "B/BK" <sup>D E</sup>	3	1502.20	PIN D10X27	3
0028.A2	MALE SHAFT "B/BK" D24	1	1506.09	SNAP RING D52	2
0029.22	RING "CK" D15.2 <sup>E</sup>	6	1506.13	SNAP RING D30	1
0208.B7	BACK COVER "B/BK"	1	1603.34	PLUG G1/4	2
0208.B8	OIL SIGHT GLASS	1	1603.62	PLUG G1/2	1
0208.B9	COVER "B/BK"	1	1603.64	PLUG G3/8	1
0209.E2	CRANKCASE "B-X/BK-X"	1	1603.H5	VALVE PLUG "BK" <sup>E</sup>	6
0216.03	BEARING D30	2	1604.03	HEAD "BK-X" <sup>E</sup>	1
0301.42	SLINGER RING <sup>C</sup>	3	1625.21	OIL PLUG G3/8	1
0303.18	NUT M8XH5 <sup>C</sup>	3	1805.06	ALLEN BOLT M8X20	12
0501.M6	BEARING FLANGE "B/BK"	2	1805.15	ALLEN BOLT M8X60	8
0605.09	GASKET D17X23X1.5	1	1805.19	ALLEN BOLT M6X25	6
0605.40	GASKET D21.5X27X1.5	1	6000.B6	CONNECTING ROD "B/BK"	3
0635.12	HIGH PRESSURE SEAL KIT D18 <sup>B E</sup>	3	6000.B7	COMPLETE CONNECTING ROD ASS'Y "B/BK"	3
0801.17	KEY A8X7X35	1	6006.29	VALVE ASSEMBLY WITHOUT O-RING <sup>A E</sup>	6
1101.66	O-RING - OIL SIGHT GLASS	1	6017.N8	COMPLETE MANIFOLD ASSEMBLY	1
1101.76	O-RING - PLUG	2	6061.28	KIT 28 - WATER SEAL KIT	1
1101.82	O-RING - PRESSURE RING <sup>B D E</sup>	3	6061.30	KIT 30 - VALVE KIT "BK"	1
1101.A3	O-RING - VALVE <sup>A E</sup>	6	6061.Q5	KIT 206 - PLUNGER KIT D15/18 "B/BK"	1
1101.G7	O-RING - VALVE PLUG <sup>E</sup>	6	6061.Q7	KIT 208 - BRASS RING KIT D18 "B/BK"	1
1101.G9	O-RING - PLUNGER ROD <sup>C</sup>	3			
1101.N6	O-RING - REAR COVER	1			
1101.N7	O-RING - BEARING FLANGE	4			

<sup>A</sup> Parts in 6061.30 (Kit 30).

<sup>B</sup> Parts in 6061.28 (Kit 28).

<sup>C</sup> Parts in 6061.Q5 (Kit 206).

<sup>D</sup> Parts in 6061.Q7 (Kit 208).

<sup>E</sup> Parts in 6017.N8 (Complete Manifold Assembly).

**GAS ENGINE GEAR REDUCTION FOR  
B/BK/BS/BWT/C/CS/CWT/CK/CX-SERIES PLUNGER PUMPS  
on GAS ENGINES with 1" SHAFTS  
REQUIRES 11.5 OZ. ISO VG 220 GEAR LUBE**

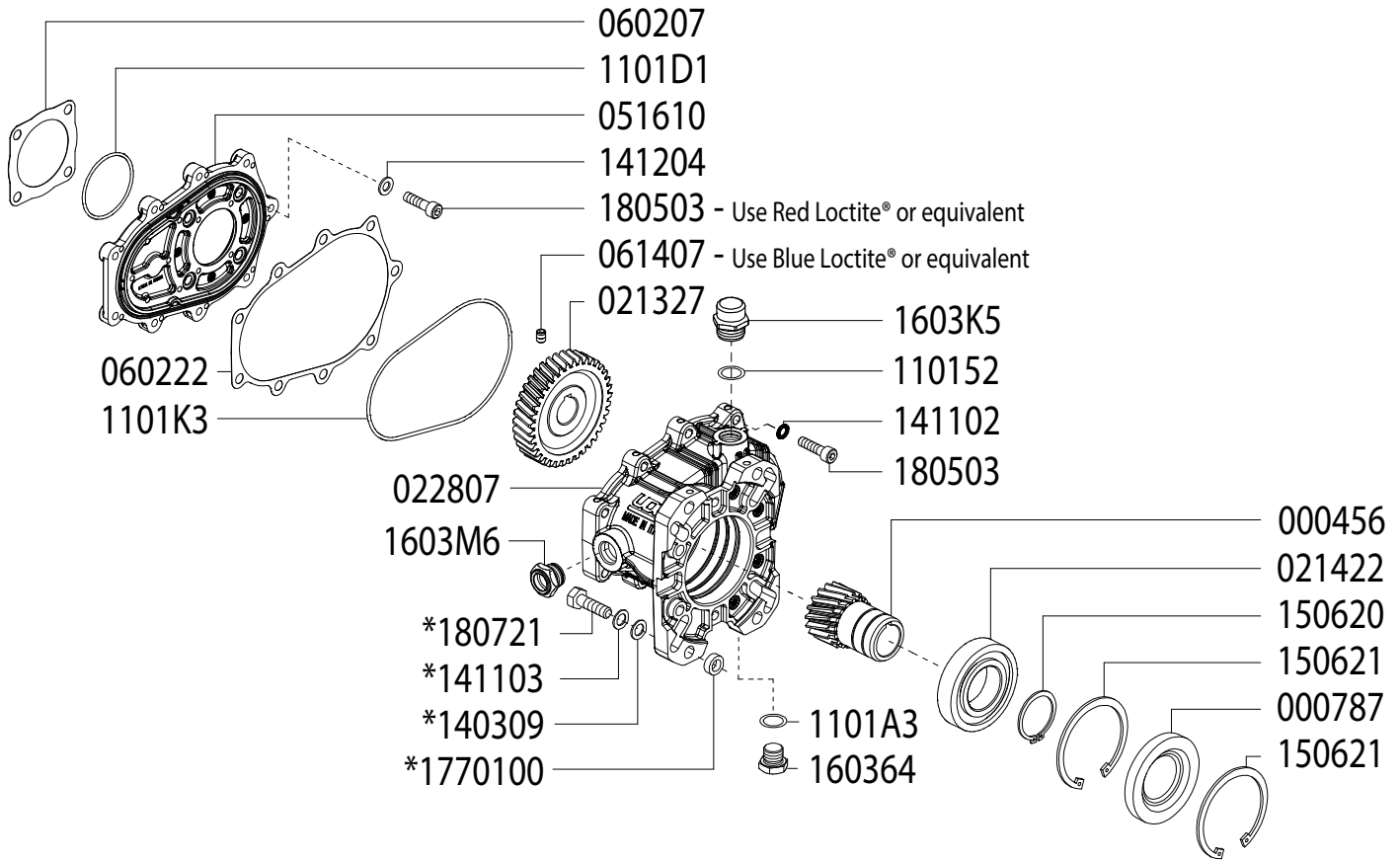

**SEE NEXT PAGE FOR ASSEMBLY AND INSTALLATION INSTRUCTIONS**

Updated 4-2-2026

Part #	Description	Qty	Part #	Description	Qty
0004.56	GEAR - 1"	1	*1403.09	WASHER	4
0007.87	OIL SEAL - D40 - RBC122K	1	1411.02	WASHER	9
0213.27	PUMP GEAR	1	*1411.03	SERRATED WASHER	4
0214.22	BEARING - D40 - RBC122K	1	1412.04	WASHER	4
0228.07	COUPLER - RBC122	1	1506.20	SNAP RING - D40	1
0516.10	FLANGE - RBC122	1	1506.21	SNAP RING - D80	2
0602.07	GASKET - RC122	1	1603.64	PLUG - 3/8"	1
0602.22	GASKET - RBC122 HOUSING	1	1603.K5	OIL PLUG - G3/8"	1
0614.07	SET SCREW - M5X8	1	1603.M6	OIL SIGHT GLASS	1
1101.52	O-RING - OIL PLUG	1	1805.03	ALLEN BOLT - M8x30	13
1101.A3	O-RING	1	*1807.21	HEX BOLT - 3/8-16 X 1-1/4"	4
1101.D1	O-RING	1	*1770.100	SPACER	4
1101.K3	O-RING	1			

\* For use when using outer mounting holes only

**GAS ENGINE GEAR REDUCTION FOR  
B/BK/BS/BWT/C/CS/CWT/CK/CX-SERIES PLUNGER PUMPS  
on GAS ENGINES with 1" SHAFTS  
REQUIRES 11.5 OZ. ISO VG 220 GEAR LUBE**

## **ASSEMBLY INSTRUCTIONS**

- 1 With the pump shaft in vertical position, remove the 4 bolts that affix the bearing flange, leaving it in its position.
- 2 Place the gasket (p/n 060207) on the pump flange and the O-Ring 1101D1 between the pump and the flange (p/n 051610), then attach the flange (p/n 051610) using the Allen Bolts (p/n 180503) with relative bonded seal washers (p/n 141204). Make sure that the O-Ring (p/n 1101K3) is correctly contained in its seat and position the gasket (p/n 060222). Apply Red LOCTITE® (or equivalent) to the bolts (p/n 180503), and tighten with a torque of 19 lb-ft MAX.
- 3 After checking that the key is correctly seated, fit the helical pinion (p/n 021327) on the pump shaft pushing it against the shaft stop and locking it in position with the set screw (p/n 061407), tightening with a torque of 15 lb-ft max (use Blue LOCTITE® or equivalent).
- 4 Complete the assembly of the gearbox crankcase by screwing the oil sight glass (p/n 1603M6) and the plug (p/n 160364) with the corresponding O-Ring (p/n 1101A3).
- 5 Attach the gearbox crankcase assembly to the flange using the (9) Allen Bolts (p/n 180503) and washers (p/n 141102), tightening with a torque of 19 lb-ft MAX.
- 6 Fill the gearbox crankcase with oil (11.5 OZ. ISO VG 220 GEAR LUBE) until the level indicated in the center of the oil sight glass, then closing with the oil plug p/n 1603K5 and O-Ring (p/n 110152).

Note: If the pump-gearbox unit is not immediately coupled to the engine and have to be transported, to avoid possible oil leaks, temporarily use a plug G3/8 (not supplied) instead of the oil plug (p/n 1603K5).

## **ASSEMBLY OF THE PUMP-GEARBOX UNIT ON THE ENGINE:**

- 1 Check that the key of the motor shaft is correctly seated, then apply a good anti-seize lubricant (such as LOCTITE® 8150) to the shaft to facilitate disassembly.
- 2 Then proceed to the coupling of the gearbox to the engine using the appropriate bolts and washers (supplied)
- 3 Tightening torques according to the bolts used.

3/8" - torque = 29 lb-ft MAX

5/16" - torque = 19 lb-ft MAX

*Dimensional Drawings are  
Shown in Millimeters.  
To Convert to Inches,  
Multiply Dimension x 0.03937*

## BK SERIES PUMPS - 24MM SOLID SHAFT

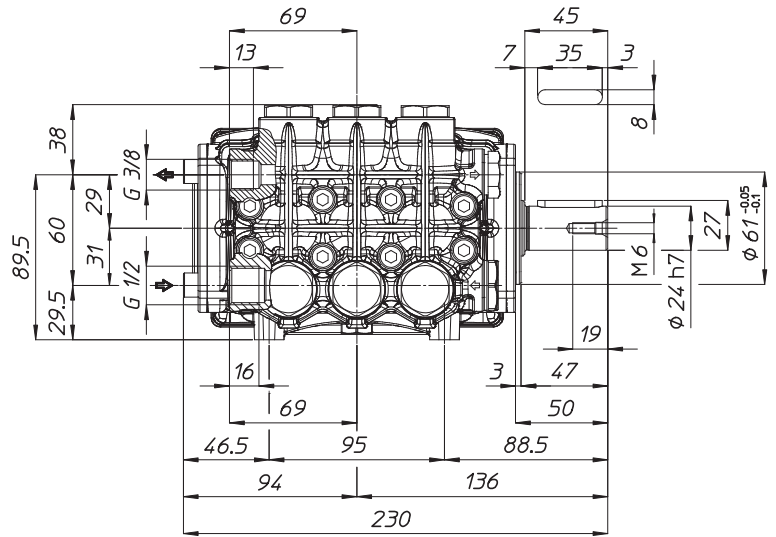
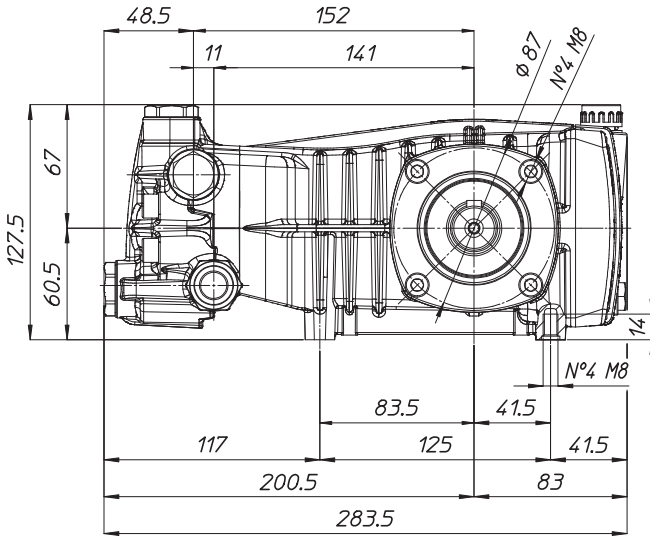

## TORQUE SPECS

Ref.	Description	Ft./lb.	Nm	Loctite®
1	Head Bolts	19	25	-
2	Valve Caps	75	100	243
3	Inlet Cap	75	100	243
4	Outlet Cap	60	80	243
5	Bearing Flange Bolts	19	25	-
6	Rear Cover Bolts	19	25	-
7	Connecting Rod Bolts	9	11	243
8	Plunger Bolts	11	15	270
9	Valve Cover Bolts	-	-	-
10	Oil Drain Plug	19	25	-

